



Halifax Regional  
School Board

# TENDER #3753

## Heating Coil BEECHVILLE LAKESIDE TIMBERLEA SCHOOL

Closing Date: *MONDAY, AUGUST 17TH, 2015*  
Closing/Opening Time: *2:00:00 P.M.*

**Closing Location:**

Halifax Regional School Board  
33 Spectacle Lake Drive  
Dartmouth, N.S. B3B 1X7

**HRSB Contacts:**

Deborah Beck, Buyer

Tel: (902) 464-2000 #2011

Fax: (902) 464-0161

Gary Mannette

Tel: (902) 464-2000 #5124

**School Location:**

**BEECHVILLE LAKESIDE TIMBERLEA SCHOOL,  
24 James Street  
Timberlea, NS**

**A mandatory bidders' site meeting is scheduled for *MONDAY, AUGUST 10, 11:00 A.M. AT THE SCHOOL.***

**To obtain documents:**

**Download tender documents in .pdf format from the School Board's**

**Website: <http://www.hrsb.ca/about-hrsb/financial-services/purchasing/tenders/tender-listing>**

*The Halifax Regional School Board encourages equity and affirmative action programs.*

# Table of Content

	<b>Page</b>
1.0 Instructions to Bidders .....	3
1.1 Conditions of Tender .....	4
1.2 Other Requirements .....	7
1.5 The Contract .....	11
2.0 Scope of Work .....	13
3.0 Contractor’s Information Sheet .....	23
3.3 Sub-contractor List .....	24
3.5 Schedule of Prices .....	26
3.7 Proposed Fixed Price .....	27

## **SAMPLE CONTRACT (DO NOT RETURN SAMPLE CONTRACT WITH BID DOCUMENTS)**

Schedule “A” Sample Agreement for Supply of Services .....	29
Appendix “A” Terms and Conditions .....	31
Appendix “B” Insurance and Risk .....	42
Appendix “C” Description of Service .....	48
Appendix “D” Undertaking to Comply & Safety Checklist .....	51

## **SAFETY PLAN/CONTRACTOR’S CHECK LIST**

Appendix “E” Project Safety Plan Outline .....	56
Appendix “F” Contractor’s Check List .....	61

## **NOTICE – CEASATION OF PUBLIC TENDER OPENINGS**

As of April 1, 2014 Public tender openings are no longer held for any tenders relating to goods, services or construction for HRSB. A list of bidders and bid amounts will be posted on the Procurement Services website (<http://novascotia.ca/tenders/tenders/ns-tenders.aspx>) shortly following the closing of the tender. All bid submissions are subject to evaluation after opening and before award of contract. The winning bidder and award amount will be posted on the Procurement Services website (<http://novascotia.ca/tenders/tenders/ns-tenders.aspx>) after evaluation.

1.0 **GENERAL**

The Halifax Regional School Board is seeking bids from qualified contractors for ***HEATING COIL at BEECHVILLE LAKESIDE TIMBERLEA SCHOOL as per the plans and specifications prepared by FOWLER, BAULD & MITCHELL LTD.***

1.1 **INSTRUCTIONS TO BIDDERS**

**TENDER  
SUBMISSION:**

- (a) Sealed Bids will be received by:

Halifax Regional School Board  
33 Spectacle Lake Drive  
Dartmouth, N.S.  
B3B 1X7

Until ***2:00:00 P.M., MONDAY, AUGUST 17TH, 2015***, (as verified by the phone clock on the Reception desk at 33 Spectacle Lake Drive) for the following projects:

***TENDER #3753 HEATING COIL – BEECHVILLE LAKESIDE TIMBERLEA SCHOOL***

***Should the School Board Office be closed for any reason the tender closing will be postponed to the next business day.***

- (b) Submit one copy of the original tender on the enclosed tender form. Each item on the form must be completed unless noted otherwise. Bids must be signed by an authorized representative of the Suppliers/Contractors. Incomplete bids will be rejected. Bids must be submitted on or before the advertised time and date in a sealed envelope clearly marked:

***TENDER #3753 HEATING COIL – BEECHVILLE LAKESIDE TIMBERLEA SCHOOL***

- (c) It is the responsibility of the bidder to ensure their submissions are received on time. Faxed bids will not be accepted.

- (d) Addenda must be issued by the Board no less than three (3) business days before tender closing. Addenda cover letters shall be signed and attached to the tender documents.

1.2 **CONDITIONS OF TENDER**

- (a) No term or condition shall be implied, based upon any industry or trade practice or custom or in a practice or policy of the Board or otherwise, which is inconsistent or conflicts with the provisions contained in these instructions.
- (b) Any changes to this tender or specifications shall be stated by the Board in writing. All correspondence, inquiries, instructions, etc. in connection with the work shall be made through the office of the Halifax Regional School Board, c/o Manager of Accounting & Purchasing or representative.
- (c) Tender price must include freight, duty, and all taxes, rates and charges, which are applicable at the time the contract is awarded. It is the responsibility of the bidder to find out from the appropriate authorities what taxes, rates and charges are applicable to this tender.
- (d) The Contractor is responsible for obtaining all provincial, municipal and other permits as required for the work, and shall adhere to all regulations from regulatory bodies, including the National Building Code, 2005. They shall pay all fees for these permits. Sub-trades are responsible for obtaining permits and following regulations as they affect their work.
- (e) Invoices shall be submitted to: Halifax Regional School Board  
c/o Operations Services Coordinator-Maintenance  
33 Spectacle Lake Drive,  
Dartmouth, NS B3B 1X7

Contact information to be supplied to the successful bidder as part of the award confirmation.

Payment: Payment terms will be considered as Net 30 days from date of invoice.

- (f) Bidders or their employees must not be employees of the Halifax Regional School Board.
- (g) The bidder must comply with Nova Scotia Fire Safety Act and all Municipal Regulations, Ordinances and other laws including the Occupational Health and Safety Act.
- (h) Persons or firms submitting tenders shall be actually engaged in the line of work required by the specifications.
- (i) When applicable, a bidder shall list, in the space provided in Section 3.3, the names of the sub-contractors they propose to use with each sub-contractor's tender price. A change in sub-contractors from this list will require permission in writing from the Board.
- (j) Except as the specifications may be modified by Addenda, the successful

contractor will be held to furnish under this tender all work as specified.

- (k) The contractor shall save, defend, and indemnify the Halifax Regional School Board against all costs which the School Board may sustain or incur by reason of any act or omission of the contractor or its' agents or sub-contractors.
- (l) Property loss and/or damage that occurs during the course of work or caused by negligence on the contractors part during the course of the work shall be reported by HRSB Operations Services to the School Insurance Program (SIP) office. Adjusters may be assigned to manage restoration of damaged, defaced or stolen HRSB property. HRSB and/or its insurer reserve the right to assign management of restoration to the adjuster. The contractor shall be responsible for all costs to repair or replace any School Board property, which has been damaged, defaced or stolen during the course of work.
- (m) The term of the contract will be from date of award to ***SEPTEMBER 30, 2015***.
- (n) Where the Tender Documents stipulate a particular product, written requests for substitutes will be considered by the Board up to five (5) business days prior to the tender closing date. Such requests shall be accompanied by complete descriptive and technical information including MSDS so that a proper evaluation can be made.

When a request for approval of a product is made, the Board may grant approval and will attempt to issue an Addendum to this effect to known bidders. However, HRSB assumes no liability for the delivery of electronic transmissions.

All products used in the course of this work are to be used, stored, and maintained as per the instructions written on the MSDS sheet.

- (o) Time and Material costs must be provided as listed in Section 3.6
- (p) **Unique Logistics**  
Completely describe how your Tender will respond to the unique logistics of each school or administrative site as set out in the Project Scope and fully describe, in the same manner, all items of equipment, service, and support you will provide to respond to those logistics and all pricing and other matters relating to them.
- (q) **HRSB Discretion**  
The Bidder hereby acknowledges that:
  - a) HRSB shall have the right to reject any or all Tenders for any reason, or to accept any tender which HRSB in its sole, unrestricted discretion deems most advantageous to it. The lowest, or any, Tender will not necessarily be accepted and HRSB shall have the unrestricted right to:
    - i) accept any Tender, and in the event it only receives informal, non-conforming or qualified Tenders with respect to this Tender, accept any such Tender; or

- ii) Accept a Tender that is not the lowest price;
  - iii) Reject a Tender that is the lowest price even if it is the only tender received;
  - iv) Reject any Tender that contains any irregularities, informalities, conditions or qualifications;
  - v) Reject any Tender that is not accompanied by the required tender security documents;
  - vi) Reject any Tender that is not properly signed by or on behalf of the Bidder;
  - vii) Reject any Tender that contains an alteration in a quote that is not initialed by or on behalf of the Bidder;
  - viii) Reject any Tender that is incomplete or ambiguous; or
  - ix) Reject any Tender that does not strictly comply with other requirements contained in these instructions.
- b) HRSB reserves the right to consider, during the evaluation of Tenders:
- i) Information provided in the Tender itself;
  - ii) Information received in response to enquiries of credit and industry references set out in the Tender;
  - iii) The manner in which the Bidder provides services to others;
  - iv) The experience and qualification of the Bidder;
  - v) The compliance of the Bidder to HRSB's requirements and specifications;
  - vi) Such alternate goods, services, terms or conditions that may be offered, whether such offer is contained in a Tender or otherwise,
  - vii) Splitting the Tender and Project Scope into multiple parts and accepting Tenders (or portions thereof) from more than one Bidder;
  - viii) Rejecting Bidder's recommendation of a Subcontractor or any other third party associated with the Tender and jointly along with the Bidder, determine alternate acceptable third parties; and
  - ix) Any other consideration in HRSB's discretion;
- c) HRSB may rely upon the criteria it deems relevant, even if such criteria has not been disclosed to Bidder. By submitting a Tender, the Bidder acknowledges the HRSB's rights under this Section and absolutely waives any right or cause of action against HRSB and its employees, agents or Trustees by reason of HRSB's failure to accept the Tender submitted by the Bidder, whether such right or cause of action arises in contract, tort including negligence or otherwise; and
- d) HRSB shall not at any time have any obligation to deal exclusively with the Bidder. HRSB expressly reserves its rights, in its sole discretion, to seek a Tender regarding the subject matter hereof, from any person whomsoever

and at any time.

(r) **Limitation of Liability**

Bidder, by submitting a bid to this Tender, agrees that it will not claim damages, costs or expenses for whatever reason, relating in any way to this Tender and any resulting process (including without limitation any subsequent discussions or negotiations, if any, or in respect of any competitive process) and waives any and all claims against HRSB whatsoever, whether for costs, damages or expenses incurred by Bidder in preparing its Tender, in participating in this tender process (including without limitation any subsequent discussion or negotiation, if any), loss of anticipated profit or any other matter whatsoever related to this tender and any resulting process, discussions or negotiations.

(s) **Construction Contract Guidelines**

The Halifax Regional School Board acknowledges and complies with the **Nova Scotia Transportation and Public Works Construction Contract Guidelines.**

1.3 **OTHER REQUIREMENTS**

- (a) The bidder must provide with the submitted tender document a certificate indicating the completion of the Nova Scotia Construction Safety Association's Construction Safety Program or other WCB approved safety audit company that jointly sign the Certificate of Recognition with the WCB.
- (b) The bidder must provide with the submitted tender document a letter showing they are in good standing with the Worker's Compensation Board.
- (c) The bidder must provide with the submitted tender document a tentative schedule indicating timelines for completion of works. **Upon award of work, the successful bidder shall provide within three (3) business days a schedule clearly indicating timelines for completion of all aspects of the project. Shop drawings/samples must be returned to HRSB for Consultant's review within five (5) days upon award.**
- (d) The bidder must provide with the submitted tender document, an insurance certificate showing **HRSB as "ADDITIONAL INSURED"** with proof of:
- (i) Commercial General Liability insurance, including but not limited to, products liability and completed operations, contractual liability, owners and contractors liability, attached machinery extensions, endorsement, independent contractor, for a combined single limit of no less than **\$5,000,000** per occurrence; Builder's Risk Insurance in the amount of the Contract Price.
  - (ii) Commercial Auto Liability insurance covering all owned, non-owned and hired vehicles for a minimum combined single limit of **\$2,000,000** per occurrence; and
  - (iii) It is also agreed that the above insurance coverage is primary.

Upon award, the bidder shall secure and maintain the insurance as noted above at its expense during the term of the contract.

The Halifax Regional School Board must be named as additional named insurance

pertaining to the work for this project. Furthermore, Halifax Regional School Board must receive at least thirty (30) days' notice of cancellation or modification of the above insurance. Bidders shall at all times keep in force insurance as may be required.

(e) **BID SECURITY**

The bidder **MUST** provide with the submitted tender document **Bid Security** in the amount of **ten percent (10%) of the Contract Price** (before HST) in the form of a Certified Cheque, Irrevocable Standby Letter of Credit or Bid Bond payable to, or naming the Halifax Regional School Board.

**BID BONDS *must be provided by a surety company licensed to issue surety bonds in the Province of Nova Scotia:***

- Provide bond on the standard CCDC Bid Bond Form, latest version, in the amount of not less than **ten percent (10%) of the Contract Price (before HST)**.
- Bid Bonds, submitted by the general contractor bidder, signed and sealed by the principal (Contractor) and Surety and shall be with an established Surety Company satisfactory to and approved by the Halifax Regional School Board.
- Where a Bid Bond is used as Bid Security, include the cost of providing the Bid Bond in the Tender Contract price.

Where **CERTIFIED CHEQUE or BANK DRAFT** is provided as bid security:

- Provide a certified cheque or bank draft, endorsed in the name of the Halifax Regional School Board, for a **sum not less than ten percent (10%) of the amount of the Contract Price (before HST)**.
- Where certified cheque or bank draft is used as Bid Security, include the cost in the Contract price.

Where the **IRREVOCABLE STANDBY LETTER OF CREDIT** is used as bid security:

- Provide an Irrevocable Standby Letter, endorsed in the name of the Halifax Regional School Board, for a sum not less than **ten percent (10%) of the Contract Price (before HST)**.
- The Irrevocable Standby Letter of Credit shall be issued by a certified financial institution subject to the Uniform Custom and Practices for Documentary Credit (1993 revision or latest revision) International Chamber of Commerce (Publication No. 500).
- Where Irrevocable Standby Letter of Credit is used as bid security, include the cost in the Tender Contract Price.

**RETURN OF BID SECURITY:**

- The bid security of the unsuccessful bidders will be returned to them after the contract has been signed, or previous to such time, at the discretion of the Halifax Regional School Board. The above shall apply provided a contract is awarded within sixty (60) days from the closing date of the bid. If no contract is awarded, all bid security will be returned.



(f) **CONTRACT SECURITY (ONLY REQUIRED FOR BIDS OVER \$100,000)**

For bids over \$100,000 bidders must provide **Contract Security by a surety company licensed to issue surety bonds in the Province of Nova Scotia** in the form of one of the following:

- Letter of Surety.
- Performance Bond and a Labour and Material Payment Bond OR
- Certified Cheque or Bank Draft OR Irrevocable Letter of Credit bearing the bidder's original signature, payable to or naming the Halifax Regional School Board as insured.

Bidder shall maintain performance assurance in force for a period of not less than twelve (12) months after the issue of the substantial performance certificate certified by Halifax Regional School Board and until completion of the contract.

Should it become apparent that the final cost of the project will **exceed the total amount payable by more than 10%**, the bidder shall arrange to have their bonds reissued based on the projected final cost.

Where a **LETTER OF SURETY** was used as **CONTRACT SECURITY**:

- Within ten (10) days after notification of award of the Contract, provide a Performance Bond and a Labour & Material Payment Bonds each in an amount **equal to fifty percent (50%) of the Contract Price (before HST)**, naming the Halifax Regional School Board.
- Performance Bond and Labour and Material Payment Bonds, submitted by the bidders, shall be provided at the expense of the bidder and shall be with an established Surety Company satisfactory to and approved by the Halifax Regional School Board.
- Include the cost of providing the Performance Bond and Labour and Material bond in the Contract price.

Where a **CERTIFIED CHEQUE OR BANK DRAFT** is used as **CONTRACT SECURITY**:

- The Certified Cheque or Bank Draft submitted during the bid period will be cashed and the amount retained by the Halifax Regional School Board shall serve as Performance Assurance, including the payment of all obligations arising under the Contract.
- The Certified Cheque or Bank Draft will be held in lieu of the Performance Bond and Labour and Material Bonds, providing that, at Contract award, the successful Bidder shall supplement their Certified Cheque or Bank Draft to maintain an amount of **twenty (20%) of the Contract price** (before HST) under the contract.
- The amount remaining will be returned without interest after a period of not less than twelve (12) months after the issue of the substantial performance certificate

certified by the Halifax Regional School Board and shall serve as performance assurance until completion of the contract.

- Where certified cheque or bank draft is used as Performance Assurance, include the cost of providing the certified cheque in the Contract price.

Where **an IRREVOCABLE STANDBY LETTER OF CREDIT** is used as **CONTRACT SECURITY**:

- The Irrevocable Standby Letter of Credit for a sum not less than **ten percent (10%) of the Contract price (before HST)** submitted during the bid period will be retained by the Halifax Regional School Board and shall serve as performance assurance, including the payment of all obligations arising under the contract. The irrevocable standby letter of credit shall be issued by a certified financial institution subject to the Uniform Customs and Practices for Documentary Credit (1993 revision) International Chamber of Commerce (Publication No. 500).
  - Where irrevocable standby letter of credit is used as Performance Assurance, include the cost of providing and Irrevocable Standby Letter of Credit in the Contract Price. The contractor shall provide to the Halifax Regional School Board documentation throughout the duration of the contract that the irrevocable standby letter of credit remains in full effect at all times as specified.
  - Upon expiry of the Irrevocable Standby Letter of Credit, a separate Irrevocable Standby Letter of Credit shall be provided for work requiring extended warranties for such amounts as are required by the contract.
- (g) The bidder must provide with the submitted tender document a completed copy of Appendix “E” Safety Plan information sheet. The contractor prior to commencement of work must have a safety plan in place for use by the contractor personnel regarding potential hazards and work practices specific to the site.
- (h) ***HRSB is directly responsible for the safety of its students and staff. Should contractors be required to work in or on school property while children are present, it is a MANDATORY HRSB REQUIREMENT that contractors assign the work to employees and/or sub-contractors who DO NOT have a CRIMINAL RECORD and who ARE NOT LISTED ON THE CHILD ABUSE REGISTRY. By checking the “Agreed” box at the bottom of clause 3.4 below you are confirming that you understand and will abide by this mandatory HRSB requirement. Failure to comply with this requirement may result in immediate contract termination.***
- (i) Contractors must submit warranty information with the tender bid submission and successful bidders must submit all appropriate warranty documents with final payment invoice.
- (j) Bidders are advised that, as per the Halifax Regional School Board Tobacco Free Schools and Workplace Policy, the HRSB endorses and supports implementation of the Nova Scotia Smoke Free Places Act 2002, which prohibits tobacco possession for persons under the age of 19 and declares that no person shall smoke in schools, school board

offices or on school grounds.

#### 1.4 **AMENDMENTS OR WITHDRAWAL OF TENDER PRIOR TO BID CLOSING**

- (a) Tender may be amended or withdrawn **by post or facsimile (902) 464-0161** PRIOR to Tender Closing date and time.
- (b) Clearly indicate on the fax transmission or submitted envelope, whether your correspondence is an amendment or withdrawal and the title of the Tender. Sign and seal as required for tender, and submit at address listed under closing location on the cover of this document.

#### 1.5 **THE CONTRACT**

##### **1.5.1 Binding Effect of Proposal and Contract Finalization**

The Bidder hereby acknowledges that its Tender constitutes a contract with HRSB, and the terms and conditions of this Tender and the bidder response (with the Tender taking precedence in the event of any inconsistency or conflict of terms) shall govern such agreement. Such contract shall remain binding upon Bidder until the earlier of:

- a) Written notice from HRSB that the Bidder's Tender is rejected as unsatisfactory; or
- b) Issuance by HRSB of its PO to the Bidder with respect to this Tender, pursuant to Section 1.2(p), and upon such issuance, the Bidder shall be regarded as the Contractor hereunder; or
- c) Execution of the Contract by both HRSB and the Bidder pursuant to Section 1.2(p); or
- d) Written notice from HRSB that it has entered a Contract with a Contractor and that the Bidder has been unsuccessful under this Tender.

##### **1.5.2 Contract Documents**

1.5.2.1 The attached form of contract (Schedule A) is a version that shall be issued to or executed by the successful bidder pursuant to the terms and conditions of this Tender. It is NOT TO BE executed and returned by the bidder as part of its (proposal or Tender response).

1.5.2.2 After the contract has been awarded and signed, the contractor will be contacted by the appropriate Regional Manager to attend a site visit to complete Appendix D of the contract – 'Undertaking to Comply and Contractors Safety Checklist' prior to the commencement of any work.

1.5.2.3 The Contract the Contractor will have with the HRSB, if awarded, will include:

- a) Such further documentation as may be negotiated and executed by the HRSB and the Contractor pursuant to Section 1.2(p); and

- b) This Tender and all of its Schedules, including without limitation any PO issued by HRSB to the Contractor, and any revisions, amendments or additional documents made thereto, if any; and
- c) The Tender, in its entirety and all promises made in the tender will be deemed covenants in the Contract and all information, representations and warranties made in the Tender will be deemed terms, representations and warranties of the Contract surviving the signing or issuance by HRSB of any additional or formal documents prepared by the HRSB.

1.5.2.4 For the purposes of evaluation and interpretation of Tenders, in the case of conflicts, discrepancies, errors or omissions between this Tender and any documentation issued or executed pursuant to Section 1.5.1, and the Tender, this Tender and such documentation shall take precedence over the Bidder response.

## **1.6 Your Contractual Terms**

- 1.6.1 List separately any contractual terms which must be included as part of the Contract if awarded to you and which would be a condition to HRSB's acceptance of your bid.
- 1.6.2 List separately any contractual terms which you would like the HRSB to consider but which would not be a condition to the acceptance by the HRSB of your bid and which would only be part of the Contract with the HRSB with the specific further agreement of the HRSB.

## **2.0 SCOPE OF WORK**

- (a) Location:

**BEECHVILLE LAKESIDE TIMBERLEA SCHOOL – HEATING COIL** as per drawings and specifications prepared by **FOWER, BAULD & MITCHELL LTD.**

- (b) School/Work site access control: **Contractor’s employees shall always report to the main office of a school or security officer, indicate who they are and state their purpose on site prior to starting any work in the school.** Contractor is not permitted to work on the school site without HRSB assigned representative on site unless authorized by HRSB Manager of Operations.

The outside work area shall be appropriately demarked and/or surrounded by a barrier to prevent unauthorized entry to the work area. All workers shall contain their activity to the work site area. The contractor shall only use the school staff designated washroom and lunchroom facilities. Access to the school shall only be allowed as planned in coordination with HRSB Operations and the school administration.

The contractor and sub-contractor employees shall maintain professional and courteous behaviour, including work and communications practices, at all times on the project site. Communications and work shall be conducted so as to minimize the effect on regular school occupants and their activities.

- (c) Project/Safety Coordination: The contractor shall provide to HRSB within one week of award of contract a fixed schedule for all aspects of completion of work. The safety plan outline provided with this document must be posted on site during the execution of work and will be accessible to all workers on the site.

Where applicable, a **hot work permit** will be required to be completed prior to commencement of work and all conditions of the permit must be maintained until completion of hot work. A copy of the hot work permit signed by the contractor representative shall be provided to HRSB upon completion of each hot work session. Contractor must assign a designated fire watch as noted on the permit document who shall remain on site for three hours after completion of each hot work session.

The contractor will provide access to the work site and safety plan for inspection by HRSB Operations Services administration, HRSB health and safety Manager, consultants, regulatory inspectors as may occur throughout the duration of the project.

All necessary project coordination communications between project personnel and HRSB or site administration shall be from the project foreman/supervisor through the school principal and/or the Manager of Operations.

- (d) Hours of work - All work shall be carried out during **regular working hours** unless otherwise indicated in writing by the Manager of Operations Services or a designate. Hours of work shall comply with local ordinances and bylaws for each site.

- (e) **Site Material Control:** The contractor shall be responsible for storage of all materials required to complete the renovation. The school shall not be used for storage of materials unless otherwise approved by the principal and manager of Operations Services. Any requirement for modifications to the building in order to allow delivery and installation of the new equipment is the responsibility of the contractor.

The contractor is responsible for security of all project materials and access to the project site and/or the school through the project site at all times until completion of work and acceptance of the finished project by HRSB. Such additional security costs for security personnel or other means of security as deemed necessary by the contractor will be the sole responsibility of the contractor.

The contractor shall keep the work site free from accumulated debris caused by the employees or work and shall remove all debris at the end of each work shift. Debris shall not be deposited in HRSB controlled garbage and/or recycling containers.

All waste materials and debris created during demolition and/or construction shall be disposed of in a dumpster provided by the contractor, to be removed at the end of the construction project, using a methodology that is in compliance with the applicable HRM solid waste by laws. Otherwise, the material must be removed and disposed of off site at the end of each working day. The waste materials may not be stored on site unless they are held in an approved project dumpster.

All temporary structures such as portable washroom facilities, materials storage trailer, work trailer, debris dumpster, vehicles, etc., shall be located a minimum of (25) twenty-five feet from the school building.

- (f) 1 Contractor is advised that the building maybe occupied when work on this project takes place. Contractor to verify all areas of construction are secured and air tight partitioned to ensure that the health and safety of the students and staff are maintained during the construction period.

**2 Temporary Construction Utilities & Closures:**

Contractor to erect and maintain 'dust-tight' barriers as noted. Prior to start-up, the 'dust-tight' separations must be in place as noted and reviewed by HRSB Project Manager and the Consultant. 'Dust-tight' enclosure will be reviewed during the course of construction. Contractor must maintain the current lighting levels, heating and ventilation standards in place.

**3 Interior Closures and Construction Areas:**

3.1 For interior/interior locations provide the following:

3.1.1 Gypsum board both sides to 9'-4", AFF.

3.1.2 3 5/8 metal stud at 16" o.c., extend every 4<sup>th</sup> stud to underside of OWSJ.

3.1.3 Provide 10ml poly from top of gypsum board to u/s deck, sealed at the top of the wall to underside of deck.

3.1.4 Provide negative pressure within the construction space exhausted to the exterior.

3.2 Tarps are not to be used in lieu of the described closures.

- 3.3 Construction Access & Storage:
  - 3.3.1 Proper access to the area and storage of materials to be provided by the owner.
  - 3.3.2 Location to be determined by Project Manager on site.
- 3.4 Provide and maintain Heating Coil equipment during performance of the work as required by insurance companies, authorities having jurisdiction and governing codes, regulations and by-laws. Ensure no access is blocked for this purpose.
- 3.5 Contractor to coordinate a staging area for the Subcontractors for equipment, tools and material storage. Locate trailers and/or lockable waterproof sheds on site as per HRSB Project Manager's instructions.
- 3.6 Provide sanitary facilities in accordance with local authority having jurisdiction.

#### **4 Indoor Environmental Protection:**

- 4.1 There are several sources of potential contamination during a construction/renovation project. These include:
  - 4.1.1 Demolition Activities:
    - 4.1.1.1 Demolition activities release dust and fibrous materials into the air. Asbestos control is essential. Insulation in ceilings and walls, and ceiling tile all have a high fiber content that may produce substantial fibrous materials during demolition. Total suspended particulate levels may be very high with a significant portion of the total being of the respirable particle sizes.
- 4.2 Construction:
  - 4.2.1 Construction introduces additional dust and fibrous materials. Many construction materials used today emit a range of volatile organic compounds, especially formaldehyde. All glues, vapours, and gases rise from solvents used to prepare surfaces for bonding, and emissions from welding and soldering can introduce a range of metals into the air.
- 4.3 Finish Work and Materials:
  - 4.3.1 Final finishing and decorating of the renovated spaces can introduce strong odours and more VOCs. Solvents, paints and varnishes, and adhesives and other glues all add to the accumulation of these irritating compounds.
- 4.4 The Contractor shall ensure site clean-up is carried out at the end of each working day. This includes partially used containers of solvents, paints, caulking, adhesives, and ensuring that these are removed from the site. All construction debris shall be removed from the site at the end of each day, either to an approved dumpster outside the building, or removed completely from the property.

#### **5 Preparation:**

- 5.1 Inspect perimeter partitions of the construction area, above the ceiling and seal all penetrations above and below the ceiling. Carefully remove the minimum number of ceiling tiles necessary to perform the inspection and the work of sealing the partitions. HEPA vacuum above remaining ceiling tiles and grid and above existing ductwork to remove loose dust prior to removal.
- 5.2 Install new temporary 'dust tight' walls and include details of the plans for location.

- 5.3 Seal all doors leading to construction areas.
- 5.4 Any existing perimeter partitions of the construction area that do not extend to the underside of deck, Contractor to extend to ensure dust-free light area between the construction area and the remainder of the school.
- 5.5 Before any construction begins, doors between the rooms where work is being carried out and the adjacent corridor must be carefully sealed. Seal the doors completely at top, bottom, and sides. All vents, ducts, openings, etc. to be sealed. Do periodic inspections to ensure seals remain tight. Provide written information to the Project Manager.
- 5.6 Negative Pressure: Implement a system that extracts air directly from the work area, and discharges this air directly outside the work area to the outside of the building. All exhausted air is to pass through a HEPA filtering system before discharge to exterior. Place negative air pressure units in the area to be constructed in order to maintain a continuous negative pressure within the construction space. The construction area **MUST** be kept at a negative pressure relative to the occupied spaces.

## **6 During Construction:**

- 6.1 Erect impermeable dust barriers to completely seal off the work area from adjacent areas.
- 6.2 Dust barriers are to be maintained and remain in place until work is completed and the facility representative has approved removal. Any damage to barriers must be repaired as soon as possible.
- 6.3 **Contractors will be held responsible for any damage, dirt or dust migration beyond the construction enclosure and all cleaning cost to rectify same will be borne by the General Contractor.**
- 6.4 Post signs on the doors indicating that there is to be absolutely no unauthorized entrance or exit through the sealed-off areas except for fire or security reasons. Ensure that the construction crew and others comply with these restrictions.
- 6.5 Clean the construction area daily.
- 6.6 Dirty or dusty footprints outside the construction area that have been left behind by people who were in the construction area are to be promptly cleaned.
- 6.7 Use water mist and commercial dust suppressing products, approved by the Owner, to control dust. Execute work by methods to minimize raising dust from construction operations.
- 6.8 In the event equipment or materials cannot be removed from the construction area, use drop sheets to cover these items.
- 6.9 Debris transported from the second floor will be by the exterior in all cases possible. Contractor to provide sealed chute to covered bins below.
- 6.10 Failure to provide adequate dust control will result in the contractor bearing the cost of any clean up, repair or replacement deemed necessary as a result of dust generated from the project.
- 6.11 Ensure that windows, doors, penetrations, electrical outlets and intake and exhaust vents are properly sealed with plastic and taped within work area.
- 6.12 For exterior work adjacent to windows in an existing facility, test window openings for air tightness and seal windows that leak.



- 6.13 Verify that all fresh air intakes facing construction operation are shut down, and sealed not to allow dust or debris intake.
- 6.14 Ventilation:
  - 6.14.1 Seal duct openings in work are until completed.
  - 6.14.2 Maintain negative pressure between work area and adjacent occupied areas by using portable ventilation equipment.
  - 6.14.3 Verify that air is exhausted directly outside and away from intake vents, or filtered through a HEPA filter before being recirculated. Where odour is a concern, ensure an approved air scrubbing material is utilized.
  - 6.14.4 The main building's air handling system shall be disconnected from use in areas of construction. This will require sealing of existing duct work on both the supply and return air systems.
- 6.15 Remedial Measures:
  - 6.15.1 Water leaks and flooding shall be reported immediately to the Project Manager.
  - 6.15.2 Detected water damage must be thoroughly investigated in consultation with the Project Manager. A plan of action will then be implemented as approved by the Project Manager.
  - 6.15.3 All investigations, removal and abatement procedures shall be conducted in a manner that does not promote dispersal of dust and spores.
- 6.16 Cleaning During Progress of Work:
  - 6.16.1 Clean work area with HEPA filter-equipped vacuums and wet mops, or both, at end of each work shift and as necessary.
  - 6.16.2 Ensure ventilation system is functioning properly and is cleaned if contaminated by soil or dust after work is complete.

## **7 After Construction:**

- 7.1 Clean work area with HEPA filter equipped vacuums and wet mop.
- 7.2 Ensure air vents and ductwork are cleaned and seals removed.
- 7.3 If required, Contractor to conduct final indoor air quality test. Submit test results to the HRSB Project Manager.

## **8 Cutting and Patching**

- 8.1 Provide openings larger than 8" in diameter in non-structural elements of Work for penetrations of structural, mechanical and electrical Work. Openings smaller than 8" diameter will be provided by the Sub-trades requiring same.
- 8.2 When floor cutting is required, Contractor to confirm there are no under-floor electrical or junction boxes. Contractor must utilize a electrically power operated floor saw.
- 8.3 Fit work airtight to pipes, sleeves, ducts, conduit, and after penetrations through surfaces.
- 8.4 At penetration of fire rated wall, ceiling, or floor construction, completely seal voids with approved fire-stopping and smoke sealing materials, full thickness of the construction element, as required to maintain the required fire resistance and smoke spread rating.
- 8.5 Refinish surfaces to match adjacent finishes: For continuous surfaces refinish to nearest intersection; for an assembly, refinish entire unit.
- 8.6 Conceal pipes, ducts and wiring in floor, wall and ceiling construction of finished areas except where indicated otherwise.

## **9 Progressive Cleanliness & Restoration of Damage**

- 9.1 Maintain Work daily in tidy condition, free from accumulation of waste products and debris. Remove waste material and debris from site at end of each working day, and dispose of off-site. Ensure permits are obtained from authorities having jurisdiction for disposal of waste and debris.
- 9.2 Provide on-site containers for collection of waste materials and debris, and provide clearly marked separate bins for recycling.

## **10 Close Out Procedures:**

- 10.1 Remove dust, stains, paint spots, soil grease, fingerprints and accumulations of construction materials, interior and exterior to the building. Perform cleaning in accordance with installer's instructions for each material. Final cleaning shall include:
  - 10.1.1 Washing exterior paved surfaces disturbed under this contract.
  - 10.1.2 Cleaning and polishing of glass and finish metals, interior of areas noted.
  - 10.1.3 Cleaning of hardware, mechanical fixtures, lighting fixtures, cover plates and equipment, including polishing of their finish metal, porcelain, vitreous and glass components.
  - 10.4.4 Removing of visible manufacturer's labels left on materials, components and equipment.
  - 10.5.5 Cleaning of new flooring and of all other flooring disturbed under this contract.

### **10.2 Maintenance materials:**

- 10.2.1 Maintenance materials provided shall be new, not damaged or defective, and of the same quality and manufacture as products provided in the work. If requested, furnish evidence as to type, source and quality of products provided.
- 10.2.2 Provide 3% of all hard tile, floor and walls and 4 liters of each paint colour specified.

### **10.3 Testing Balancing and Adjusting**

Provide testing and ensure agency is a current member of AABC certified to perform services.

### **10.4 Demonstration of systems and equipment**

Provide complete demonstration of all systems and equipment in the presence of the Owner and maintenance representations at the following times:

### **10.5 Submittals**

- 10.5.1 Provide with application for substantial completion certificate.
  - 10.5.1.1 Certificate of final inspection report from electrical utility or inspection.
  - 10.5.1.2 Other reports required or specified.
  - 10.5.1.3 Maintenance manuals and operating instructions.
- 10.5.2 Submit with application for release of final payment:
  - 10.5.2.1 Final project record drawings including shop drawings.
  - 10.5.2.2 Performance bonds which shall remain in effect for one year after takeover date.

- 10.5.2.3 Completed Liability Insurance Policy extended for one year over date.
- 10.5.2.4 Written guarantee covering all workmanship and materials used in the work.
- 10.5.2.5 Certificate from Worker's Compensation Board.
- 10.5.2.6 Maintenance Bonds as specified.
- 10.5.2.7 Maintenance Manual.
- 10.5.2.8 Spare parts and maintenance materials and list.
- 10.5.2.9 Extended warranties.

**10.6 Substantial performance and final inspection procedures:**

10.6.1 Provide:

An inspection of the work, identify deficiencies and defects; repair as required. Notify the consultants in writing and request Substantial Performance Final Inspection.

10.6.2 Present at the Substantial Performance Inspection will be:

10.6.2.1 The consultants and his sub-consultants that he requires and notifies.

10.6.2.2 The Owner and his consultants upon notification by the design builder.

10.6.2.3 The design builder and such sub-contractors that he considers are required.

10.6.3 The Contractor will compile a Substantial Performance deficiency list at this inspection and issue it to the Owner and his consultants.

10.6.4 Upon the Owner's completion of the deficiencies, the design builder shall submit an application for final payment and a certificate for payment will be issued by the consultant to the Board.

**10.7 Substantial performance:**

10.7.1 The owner will issue a Certificate of Substantial Performance when satisfied outstanding deficiencies noted during inspections prior to the Substantial Performance inspection have been corrected, and the work is substantially performed.

10.7.2 The owner reserves the right to occupy and use portions of the building(s), whether partially or entirely completed, or whether completed on schedule or not, provided such occupancy does not interfere with the Design Builders continuing work. Partial occupancy or installation by the Owner of his equipment shall not imply acceptance of Substantial Performance, in whole or in part, nor shall it imply acknowledgement that terms of the agreement are fulfilled.

10.7.3 The Certificate of Substantial Performance will be attached to the list of remaining deficiencies to be rectified before final acceptance.

10.7.4 Make submissions specified in this section.

**10.8 Completion certificate:**

- 10.8.1 The owner will issue a Certificate of Performance when he is satisfied that outstanding deficiencies noted during inspections have been corrected and the work is complete.
- 10.8.2 A list of remaining deficiencies to be rectified before final acceptance will be attached to the completion certificate.
- 10.8.3 Make submissions specified in this section.

**10.9 Warranties:**

- 10.9.1 Establishment of warranties:
  - 10.9.1.1 Warranties shall commence on date of approval of the Substantial Performance Certificate.
- 10.9.2 Warranty period:
  - 10.9.2.1 The Owner will notify the design builder of defects observed during warranty period and request him to remedy the defects in accordance with the contract documents.
  - 10.9.2.2 Thirty days before the expiration of warranties, the Owner and the design builder will inspect the work as arranged by the design builder noting defects of products and workmanship.
  - 10.9.2.3 The designer builder shall immediately remedy such noted defects.

## 2.1 **SITE VISITS**

- (a) Bidders will be deemed to have familiarized themselves with existing site and all other conditions which may affect performance of the Contract. No plea of ignorance of such conditions as a result of failure to make all necessary examinations and calculations will be accepted as a basis for any claims for extra compensation or an extension of time.
- (b) **A mandatory bidder's site meeting is scheduled as per the directions on the cover sheet of this document.**

## 3.0 **FORM OF TENDER - BIDDER DECLARES**

- (a) That this tender was made without collusion or fraud.
- (b) That the proposed work was carefully examined.
- (c) That the bidder is familiar with local conditions.
- (d) That contract documents and attachments were carefully examined.
- (e) That all the above were taken into consideration in preparation of this tender.

## 3.1 **BIDDER AGREES**

- (a) To enter into a contract to supply all labour, material and equipment and to do all work necessary to complete the Work as described and specified herein for the prices as per the Form of tender, Schedule of Prices, Article 3.5.
- (b) That this tender is valid for acceptance for 60 days from the time of tender Closing.
- (c) That failure to enter into a formal contract and give specified documents within time required will constitute grounds for forfeiture of this agreement.
- (d) That if Certified Cheque or bid bond is forfeited, the Owner will retain difference in money between amount of tender and amount for which owner legally contracts with another party to perform the work and will refund balance, if any, to bidder.
- (e) I/WE certify that the company listed herein is in good standing with the City of Halifax Tax Collector and all Municipal, Provincial and Federal Tax Agencies. Failure to complete this certification and maintain this status will be cause for rejection of your tender and/or cancellation of any contractual undertaking with the Board. We further agree with and accept the terms set out in this tender document.

*Halifax Regional School Board*

**CONTRACTOR INFORMATION SHEET**

***TENDER #3753  
HEATING COIL  
BEECHVILLE LAKESIDE TIMBERLEA SCHOOL***

FIRM \_\_\_\_\_

ADDRESS \_\_\_\_\_

\_\_\_\_\_

E-MAIL ADDRESS \_\_\_\_\_

POSTAL CODE \_\_\_\_\_ PHONE \_\_\_\_\_ FAX \_\_\_\_\_

NAME OF PERSON SIGNING FOR FIRM \_\_\_\_\_

POSITION OF PERSON SIGNING FOR FIRM \_\_\_\_\_

The undersigned company represents and warrants that it is authorized to carry on business of this nature and that it is not prohibited by any law applicable in Nova Scotia from performing this Contract. The undersigned also acknowledges receipt and understanding of, and has taken into consideration all information presented in, this tender and agrees to be bound by its terms and conditions. The undersigned further confirms and agrees that the person whose name is set out below is fully authorized to represent the company and to bind it to this bid and the Contract awarded pursuant to it and in all matters relating to or arising out of the subject matter of this tender.

I/WE, the undersigned, having carefully examined the ***#3753 HEATING COIL – BEECHVILLE LAKESIDE TIMBERLEA SCHOOL*** tender documents, and having read, understood, and accepted the Conditions of the tender which form part of the tender documents, hereby offer to provide the materials and service in strict accordance with the ***#3753 HEATING COIL – BEECHVILLE LAKESIDE TIMBERLEA SCHOOL*** documents, which form part of this tender.

I/WE, hereby agree that notification of acceptance of this bid shall be in writing and may be sent by prepaid post or fax, and if sent by prepaid post, acceptance shall be deemed to have been made on the date of mailing of such notification.

3.2 **REFERENCES:**

The Bidder shall furnish particulars of at least three contracts successfully completed or currently being carried to completion. The projects quoted should preferably be approximate in nature to the Works now proposed for and be of comparable or greater size.

Contact Name & Phone #	Date	Contract Value
_____	from _____ to _____	_____
_____	from _____ to _____	_____
_____	from _____ to _____	_____
_____	from _____ to _____	_____

3.3 **SUB-CONTRACTORS:**

The Bidder shall enter the name and address of each Sub-Contractor used in making up this Tender. Only one Sub-Contractor shall be named for each part of the work to be sublet.

Subcontractor/Suppliers/Manufacturers	Service/Material





3.5 **SCHEDULE OF PRICES**

**CONTINGENT UNIT PRICES:** [see article 1.2 (p)]

Provide unit prices for contingency items in the event that additional work items are required in association with the scope of work as outlined in section 2.0 and the total value of unit prices shall be included in the Total Fixed Cost price.

Item No.	Description	Unit of Measurement	Unit Price
1.	_____	_____	\$ _____
2.	_____	_____	\$ _____
3.	_____	_____	\$ _____
4.	_____	_____	\$ _____
5.	_____	_____	\$ _____

3.6 **TIME AND MATERIAL PRICES:**

Provide unit prices for time and material work if no fixed price is requested in association with the work as outlined herein.

Item No.	Description	Unit of Measurement	Estimated Quantity	Unit Price
1.	_____	_____	_____	\$ _____
2.	_____	_____	_____	\$ _____
3.	_____	_____	_____	\$ _____
4.	_____	_____	_____	\$ _____
5.	_____	_____	_____	\$ _____
6.	_____	_____	_____	\$ _____

3.7 **PROPOSED FIXED PRICE**

The fixed price shall be the full inclusive value of the work. The prices submitted shall be all-inclusive and shall include for all the general and special requirements to meet the specifications of the work, including any contingent costs.

<u>Description</u>	<u>Total Fixed Price</u>
<b>HEATING COIL</b>	\$ _____
<b>BEECHVILLE LAKESIDE TIMBERLEA SCHOOL</b>	
<b>HST (15% OF TOTAL PRICE)</b>	\$ _____
<b>TOTAL CONTRACT PRICE</b>	\$ _____

SUBSTANTIAL PERFORMANCE DATE: \_\_\_\_\_

BIDDERS HST REGISTRATION NO. \_\_\_\_\_

3.8 **SIGNATURE:**

SIGNED AND DELIVERED  
in the presence of:

**CONTRACTOR**

\_\_\_\_\_  
Company name

\_\_\_\_\_  
Witness

\_\_\_\_\_  
Signature of Signing Officer

\_\_\_\_\_  
Name and Title (printed)

**SCHEDULE A**

**AGREEMENT FOR SUPPLY OF SERVICES**

This Agreement made effective on the \_\_\_\_\_ day of \_\_\_\_\_ in the year 20

**For:**

**Project Name:**

**Location:**

**Tender #**

by and between:

**HALIFAX REGIONAL SCHOOL BOARD ("HRSB")**

and

**COMPANY NAME:**

**ADDRESS:**

**CITY:**

**PROV:**

**Postal Code:**

(the "Contractor")

**The parties agree as follows:**

1. Contractor shall provide to HRSB the services set forth in Appendix "C" – Description of Services, and accompanying Exhibits (which along with all other obligations of Contractor set forth in this Agreement shall constitute the "Services") in accordance with the terms of this Agreement.
2. This Agreement consists of the following parts (together, the "Agreement"), each of which shall be construed as an integral part of this Agreement:

**This signature page**

**Appendix "A" – General Terms and Conditions**

**Appendix "B" – Risk Management & Safety**

**Appendix "C" – Description of Services**

**Exhibit A – RFP or Invitation to Tender**

**Exhibit B – Response to RFP or Tender**

**Appendix "D" – Undertaking to Comply Form and Contractor Safety Checklist**

**Appendix "E" – Safety Plan**

**Appendix "F" – Contractor Checklist**

The above Appendixes and Exhibits are intended to be complementary, and what is required by any one shall be as binding as if required by all.

3. Contractor confirms that it has read this Agreement before signing it.

4. The individual signing below for Contractor warrants by his/her signature hereon that he/she has authority to bind Contractor to this Agreement.

**HALIFAX REGIONAL SCHOOL BOARD**

**CONTRACTOR**

Signature: \_\_\_\_\_

Signature: \_\_\_\_\_

Name (print): Kathryn Burlton

Name (print): \_\_\_\_\_

Title (print): *Purchasing Manager*

Title (print): \_\_\_\_\_

Date: \_\_\_\_\_

Date: \_\_\_\_\_

**SAMPLE ONLY**

**CONTRACTOR'S ATTENTION IS SPECIFICALLY DRAWN TO THE APPENDIX "A" TERMS AND CONDITIONS GOVERNING THIS AGREEMENT. EXECUTING PARTIES' ATTENTION IS DRAWN TO APPENDIX "C" AND APPENDIX "C" TO BE INITIALED OR EXECUTED BY EACH PARTY IN ACKNOWLEDGMENT OF THE TERMS THEREIN.**

**APPENDIX "A"**

**TERMS AND CONDITIONS**

**SERVICES**

**Services:** Contractor shall provide the Services to HRSB in accordance with the terms of this Agreement, on the HRSB properties specified in Appendix "C" (the "**Description of Services**"). Except as may be otherwise expressly provided in Appendix "C", Contractor shall provide all the equipment, personnel, supplies, consumables, supervision and labour necessary to complete the Services in a good and workmanlike manner. No changes or modifications to the Services or otherwise to this Agreement shall be valid unless made in accordance with Article 5 of this Agreement. The Contractor shall employ a competent supervisor who shall be in attendance at the place of work at all times while Services are being performed.

**Term:** This Agreement shall commence upon and later expire upon the dates specified in Appendix "C" (such period being the "**Term**"), unless earlier terminated in accordance with the provisions of this Agreement. Should Contractor continue to provide, and HRSB continue to pay, for the Services beyond the Term, such provision of Services shall be deemed to be on a temporary basis only and terminable at any time by HRSB with or without cause, and the provisions of this Agreement shall apply in full force (save as to the termination provisions in Article 9) until such termination.

**FINANCIAL TERMS, PAYMENT, LIENS**

**Contract Price:** For and in consideration of the Contractor providing the Services in accordance with the terms of this Agreement, the HRSB agrees to pay to the Contractor the sum of

**SAMPLE ONLY**

\$

(*plus HST*) hereinafter referred to as the "**Contract Price**". Such Contract Price shall include any and all expenses Contractor may incur in the performance of the Services.

**Invoices:** The Contractor shall submit a single invoice to HRSB for all Services rendered under this Agreement unless Appendix "C" provides otherwise. Contractor's invoice shall indicate applicable sales and use taxes as separate amounts and indicate the net taxable value including all applicable discounts. HRSB shall not be obligated to pay any taxes to Contractor unless Contractor is registered with the applicable authorities and provides its registration number on the invoice. Contractor's invoice shall be in a form acceptable to HRSB and contain sufficient details to ascertain the scope of Services performed and, if requested, Contractor shall provide documentation in support of an invoice. If HRSB disputes any portion of the invoice, it shall pay such invoice less the disputed amount, subject to adjustment upon resolution of the dispute. Non-payment by HRSB of any amount in dispute shall not alleviate, diminish or modify in any respect Contractor's obligations to perform as required by and in accordance with this Agreement.

**Payment of Invoices:** Upon the HRSB certifying that the Services have been completed, the HRSB shall pay to the Contractor, thirty (30) calendar days from the date of such certification,

unless otherwise stipulated in Appendix "C", the full Contract Price due and payable hereunder, less any holdback required to be retained under the *Builder's Lien Act* of Nova Scotia (the "*Builder's Lien Act*"), other statutory obligation or as otherwise stipulated in Appendix "C", provided the Contractor has submitted the following:

a written statement from the supplier(s) of all materials used for the Services certifying that payment has been made in full for same or waivers of liens from such supplier(s) in due form;

a worker's wage statement containing all the information required by the HRSB pertaining to the Contractor's, and all of its subcontractors', workers. Such statement requires the name of the workers, hours worked, rate of pay, total wages received, and a signature from each worker certifying that they have received payment in full for all time worked on the job indicated on the form; and

certification that the statement is correct.

**Release of Holdbacks:** No holdback shall be paid to the Contractor until the Contractor has provided to the HRSB a statutory declaration in a form as set forth in Canadian Construction Documents Committee ("CCDC") Document 9A, together with evidence of compliance with the *Workers' Compensation Act*, and, if applicable, a copy of the Certificate of Title for the Lands, dated thirty (30) calendar days from the issuance of the Certificate of Substantial Performance (as defined in the *Builder's Lien Act*) of work by the Contractor, confirming that no liens have been placed against the Lands in association with Contractor's Services.

**Liens:** Contractor shall keep the Lands and all HRSB property free from any and all laborers', materialmen's and mechanics' liens and similar claims and encumbrances. To the fullest extent permitted by law, Contractor waives all rights to assert such liens against the Lands and all HRSB property. If Contractor fails to release and discharge any claim of lien of others against the Lands and HRSB property within FOUR (4) business days of receiving notice from HRSB, HRSB may at its option discharge or release the claim of lien, or otherwise deal with the lien claimant, and Contractor shall be liable to and shall pay HRSB any and all costs and expenses of HRSB in doing so, including all reasonable legal fees and expenses. Notwithstanding the foregoing, for the purpose of enforcing the terms of this Agreement, HRSB may apply for the following liens and rights when circumstances deem it necessary:

if the Contractor contracts for one or more jobs with HRSB, the HRSB shall have a lien on the Contract Price and extras on that job as well as on their other jobs with the HRSB;

the HRSB shall have a lien on the Contractor's equipment or supplies on any job; and

in the case of Contractor, without sufficient cause (in the opinion of the HRSB), suspending work on any job which continues for more than two (2) days, HRSB may take possession of any materials delivered to or for the Contractor on such job and use same, giving the Contractor credit for its value at not more than cost thereof to the Contractor, against any liability of the Contractor to the HRSB and may use any of the Contractor's equipment that was in use on any of the HRSB's premises until the completion of the unfinished work.

**Tax:** Contractor shall comply with all applicable tax laws, including but not limited to laws relating to: (i) the collection and remittance of HST; and (ii) the withholding of applicable taxes from those of its employees performing work under this Agreement. Contractor shall be liable for and shall indemnify HRSB in respect of any claims, penalties, interest or costs made or assessed against HRSB arising from Contractor's non-compliance with tax laws.

**Audit:** Contractor shall keep and maintain true and correct books, records and accounts with respect to the Services and any materials supplied in relation to the Services, along with invoices and monthly summaries, for a period of seven (7) years after Contractor ceases to provide the Services. Contractor shall, upon request of HRSB, make available and permit HRSB during such period to inspect, make copies of, and audit all such records. If there is any revision to charges as a result of an audit, within thirty (30) days of the audit Contractor shall pay to HRSB the full amount of any credit or HRSB shall pay to Contractor the full amount of any shortfall, as the case may be. The provisions of this Section shall survive the termination of this Agreement.

### **DUTIES OF THE CONTRACTOR**

**Sub-Contractors:** Contractor shall not subcontract the whole or any part of the Services without first receiving the written consent of HRSB, which consent may be withheld in HRSB's sole discretion. Where such consent is granted, Contractor shall not be released or relieved from any obligations or liabilities of Contractor under this Agreement nor shall HRSB be prevented from pursuing any legal or equitable remedies it may be entitled to against Contractor. Contractor shall remain liable and responsible to HRSB for the actions and omissions of any subcontractor and shall ensure that any subcontractor strictly adheres to all terms of this Agreement, including any safety requirements referred to in this Agreement. When requested by HRSB, Contractor shall provide HRSB with all details concerning any and all subcontracted work.

**Site Representative and Instructions:** The Contractor shall identify in the Undertaking to Comply attached in Appendix "D" to this Agreement, a job site representative to act on the Contractor's behalf. This representative shall have the authority to represent the Contractor with relation to taking instruction on behalf of Contractor and entering agreements or taking such other actions on matters related to this Agreement. HRSB shall identify in Appendix "C" Description of Services, or through subsequent notice to Contractor, its project manager, who has the authority to represent HRSB and instruct Contractor on matters related to this Agreement. If the Contractor representative is not on the job site at the time of a visit by HRSB's project manager, the orders of the HRSB project manager to any worker present shall be carried out. Contractor shall not seek direction from any person on matters related to this Agreement, other than from the HRSB project manager.

### **DELAYS**

**Delays:** If the Contractor is delayed in the performance of the Services, and such delay is outside the Contractor's direct control, then the schedule to perform the Services may be extended for such reasonable time as the HRSB may decide in consultation with the Contractor. No such extension shall operate to extend the Term of this Agreement. Weather is not considered a reason for delay. No extension shall be made for delay unless written notice of

delay is given to the HRSB not later than two (2) working days after the commencement of delay, providing however, that in the case of a continuing cause of delay only one notice of claim shall be necessary, and for only such period as approved by HRSB in writing, in its discretion.

**Delay by HRSB:** The HRSB will not, except by written notice to the Contractor, stop or delay the Services as a result of pending instructions or proposed changes in the Services.

**Adherence to Schedule:** If the Contractor is delayed in the performance of the Services by any cause within the Contractor's control, the Contractor shall at no cost to the HRSB take effective action to restore the Services to the original time schedule for their completion, whether or not such schedule is appended to this Agreement.

## **CHANGES IN THE WORK**

**Change Orders:** The HRSB, without invalidating this Agreement, may make changes in the Services with the Contract Price and Term being adjusted accordingly, by written notice of change (a "**Change Order**"). No changes in the Services shall proceed without a Change Order signed by the HRSB and no claim for a change in the Contract Price or change in the Term shall be valid unless so ordered and at the same time valued by the Contractor as provided in Section 5.2.

**Change Approvals:** When a change in the Services is proposed or required, the Contractor shall present to the HRSB for its approval the value of the change whether an extra charge or a credit. Changes submitted for approval are to be accompanied by a detailed breakdown of labour and materials, to which shall be added supervision, overhead and profit charges. Change charges submitted shall be calculated in the following manner:

for work done by the Contractor, add to the net direct cost not more than ten (10%) percent for overhead, profit, supervision and bonding costs; and

for work done by any subcontractor, add to the net direct cost, not more than FIVE (5%) percent for overhead and profit payable to the subcontractor, and add not more than FIVE (5%) percent to the subcontractor's amount for supervision of the subcontractor by the Contractor and for bonding costs.

The HRSB will satisfy itself as to the correctness of such claim and, when approved by the HRSB, a Change Order shall be issued to the Contractor amending the Contract Price and Term as appropriate.

## **DEFECTIVE WORK & DISMISSAL OF WORKERS**

**Defective Work:** Defective work is work that has been rejected by the HRSB as failing to conform to this Agreement. Contractor shall promptly correct defective work, as required to conform to this Agreement, with no change in Contract Price. If, in the HRSB's opinion, it is not expedient to correct defective work, the HRSB may deduct from the Contract Price the difference in value between the Services as performed and that required by this Agreement, the amount of which will be reasonably determined by the HRSB.



**Dismissal of Workers:** The Contractor shall, on the request of the HRSB, immediately dismiss from the job any person employed by the Contractor who may, in the opinion of the HRSB, be incompetent or for misconduct, and such persons shall not again be employed on the job without the prior written permission of the HRSB. Foul language will be considered as misconduct.

## **PRODUCT OPTIONS AND SUBSTITUTIONS**

**Product Selection:** Contractor may:

for any products specified by non-proprietary specification in Appendix "C", select any product of any manufacturer which meets the requirements of this Agreement.

for products specified by proprietary specification and accompanied by words indicating that substitutions will not be accepted in Appendix "C", select any product or manufacturer named. Substitutions are not permitted; and

except where substitutions are not permitted, when a product is specified by proprietary specification, other unnamed products will be accepted, subject to such substitutions being the same generic type, and capable of performing the same functions and meeting or exceeding the standards of quality and performance, as the named product. Substitutions shall not require revisions to this Agreement or a Change Order.

**Product Substitutions:** When making a substitution, the Contractor shall represent in writing that:

Contractor has investigated substitute products and/or manufacturer and has determined that the substituted product meets the criteria specified in Section 7.1 (c);

Contractor will make any changes to the Services necessitated by the substitution as required for the Services to be complete in all respects; and

Contractor waives all claims for additional costs and time caused by substitution, which may subsequently become apparent.

## **COMPLIANCE WITH LAWS, SAFETY AND PRIME CONTRACTOR**

**Compliance with Laws:** Contractor shall comply with, and shall ensure subcontractors comply with, all applicable federal, provincial, and municipal laws, regulations and by-laws and to all other applicable orders, rules and regulations of any authority having jurisdiction respecting the Services, including without restriction all applicable environmental legislation, employment standards codes and workers' compensation legislation or equivalent legislation. CONTRACTOR SHALL FURNISH HRSB WITH WRITTEN CONFIRMATION FROM THE APPLICABLE WORKERS' COMPENSATION AUTHORITIES, OR EQUIVALENT AUTHORITIES, THAT CONTRACTOR AND ANY SUBCONTRACTORS ARE IN GOOD STANDING WITH SUCH AUTHORITIES, AND NO CONTRACTOR INVOICE SHALL BE PAYABLE UNTIL SUCH CONFIRMATION IS RECEIVED.

**Safety:** Contractor shall comply with and shall ensure all of its agents, employees and subcontractors comply with all applicable fire, safety, health, and environmental laws and regulations, including all safety, health and environmental requirements pursuant to any government permit, license, or authorization. Contractor shall be solely responsible for ensuring the safety and health of its agents, employees and subcontractors and for ensuring that its activities do not compromise the safety of HRSB's operations.

**Occupational Health and Safety Legislation:** Contractor shall comply with all applicable provisions of the *Occupational Health and Safety Act* (Nova Scotia) (the "**Act**") regulations thereto. Contractor shall execute and provide to HRSB the Undertaking to Comply Form with attached Pre-Construction Meeting Contractor Safety Checklist attached as Appendix "D". Contractor shall also supply to HRSB a Certificate of Recognition (COR) form as required under the Act and other applicable legislation.

**Designation of Prime Contractor:** The parties agree to designate in Appendix "D" that the Contractor shall be the "prime contractor" for the work site on the Lands for the purposes of the Act, during the Term, under this Agreement. The Contractor hereby agrees that:

such obligation shall extend to protect all contractors, employees, workers and persons as specified in the Act concerning the work site notwithstanding that they have been retained by HRSB after the date of execution of Appendix "D" by the Contractor; and

HRSB may in its sole discretion notify the Contractor in writing that the Contractor shall, following the date of such notice, assume the role of the "prime contractor" under the Act with respect to the work site notwithstanding that the Contractor was not so designated in Appendix "D" at the time of its execution by the Contractor, and the Contractor hereby agrees to do so.

**Responsibilities of the Prime Contractor:** Contractor shall:

direct all subcontractors, other contractors, employers, workers and any other personnel at the work site on safety related matters, to the extent required to fulfill its "prime contractor" responsibilities pursuant to the Act, regardless of:

whether or not any contractual relationship exists between the Contractor and any of these entities, or

whether or not such entities have been specifically identified in this Agreement;

ensure all obligations under the Act are strictly adhered to by all personnel;

be diligent in ensuring that its subcontracts comply with all health, safety and environmental legislation;

take appropriate disciplinary action against subcontractors who contravene health, safety or environmental legislation, which includes but is not limited to the suspending of the work performed by the subcontractors, before allowing them to continue to work on the site; and

ensure that Contractor or subcontractors never place the HRSB students, staff, volunteers or the general public at risk of injury or illness related to work conducted under this Agreement.

The HRSB shall provide Contractor, where applicable, with a list of all subcontractors under contract to the HRSB, working on the work site at the same time as Contractor, as well as their contact information. Failure by the HRSB to provide such information to Contractor shall not relieve Contractor of its obligation under this Section 8.5.

**HRSB Access:** At all times during the Term, HRSB Project Managers, agents and designates shall have the right to access, ingress and egress any work site, building or facility where Contractor performs the Services, and any part thereof, for any purpose, and neither Contractor nor its subcontractors shall refuse such access, ingress or egress whatsoever.

## TERMINATION

**Insolvency:** If the Contractor should be adjudged bankrupt, or makes a general assignment for the benefit of creditors because of insolvency or if a receiver is appointed, the HRSB may, without prejudice to any other right or remedy it may have, by giving the Contractor or receiver or trustee in bankruptcy written notice, immediately terminate this Agreement.

**Breach by Contractor:** If the Contractor should neglect to prosecute the Services properly or otherwise fail to comply with the requirements of this Agreement, the HRSB may notify the Contractor in writing that it is in default of its obligations and instruct it to correct such default within FOUR (4) business days immediately following the receipt of such notice. If the correction of the default cannot be completed in the FOUR (4) business days specified, the Contractor will be considered to be actually attempting to cure the default if it:

commences the correction of the default on a best efforts basis, in HRSB's sole opinion, within FOUR (4) business days of receiving a notice of default;

provides the HRSB with a schedule for such correction which HRSB approves by written notice to Contractor; and

completes the correction in accordance with such approved schedule and without any additional cost or delay to the HRSB.

If the Contractor fails to correct the default in the time specified or subsequently agreed upon, the HRSB, without prejudice to any other right or remedy it may have, may terminate the Contractor's right to continue with the Services in whole or in part, and/or terminate this Agreement. Such termination must be in writing to the Contractor upon thirty (30) days notice.

**Other Remedies:** If this Agreement is terminated in whole or in part by the HRSB as a result of the default of the Contractor, the HRSB shall be immediately entitled to withhold any and all further payments which may be due and owing to the Contractor, complete or hire a third party to complete the Services in a manner it determines to be expedient, or to do whatever else it deems prudent or expedient in the circumstances to complete the Services.

**Safety Default:** This Agreement may be immediately terminated by HRSB for non-compliance by Contractor of any of its obligations under Article 8 of this Agreement.

## DISPUTE RESOLUTION

**Disputes Generally:** Disputes between the Contractor and the HRSB as to the interpretation, application or administration of this Agreement or any failure to agree where agreement between the parties is called for, which are to be resolved between the parties, shall be settled by mediation and/or by arbitration.

**Use of Mediation.** Should HRSB choose to mediate a dispute:

Mediation shall take place on a confidential, without prejudice, basis with a single trained mediator who is a member of the Nova Scotia Arbitration and Mediation Society, jointly selected by the Contractor and the HRSB (the “**Mediator**”). The Mediator must be impartial and independent with no involvement in the dispute. This impartiality must be assessed by each of the parties prior to mediation. If a bias or perception of bias develops during the mediation, either party or the Mediator may terminate the mediation.

The Contractor, the HRSB and the Mediator shall agree on the fees, timing and any specific procedures and shall share the costs of mediation equally. All parties shall agree to and sign an agreement to mediate drawn up by the Mediator prior to mediation.

**10.3 Arbitration:** By written notice by one party to the other (a "Notice of Arbitration"), all disputes arising out of this Agreement, including its interpretation, must be submitted to binding arbitration in accordance with the provisions of the *Commercial Arbitration Act* (Nova Scotia), subject to the following:

- (a) The arbitration panel will consist of one arbitrator. If the parties fail to reach agreement on the selection of the arbitrator within 10 days following delivery of the Notice of Arbitration, any party may apply to The Supreme Court of Nova Scotia to appoint the arbitrator. The arbitrator will be qualified by education, training and industry experience to rule upon the particular dispute to be resolved.
- (b) The arbitrator will be instructed that time is of the essence in the arbitration proceeding and, in any event, the arbitration award must be made within 90 days of the submission of the dispute to arbitration and within 15 days of the conclusion of any hearing, or if there is no hearing, within 15 days of the delivery of written submissions.
- (c) The arbitration will take place in Halifax, Nova Scotia or such place as the parties may agree and will be conducted in the English language.
- (d) The arbitration award will be given in writing and will be final and binding on the parties. The award will give reasons and will deal with the question of costs of the arbitration and all related matters. The contractor and the HRSB shall share the costs of arbitration equally, unless otherwise determined by the Arbitrator.
- (e) The parties will keep all matters relating to the arbitration strictly confidential. The existence of the proceeding and any element of it (including any pleadings, briefs or other documents submitted or exchanged, any testimony or other oral submission in any award) will not be disclosed except to the arbitrator, the parties, their counsel and any person necessary to the conduct of the proceeding, except as may be required by law or as may be lawfully required in judicial proceedings relating to the arbitration.

## PERFORMANCE BOND

**Bond Requirement:** Contractor shall, on execution of this Agreement, provide and pay for a performance bond in the amount of fifty (50%) percent of the Contract Price and a labour and materials payment bond in the amount of fifty (50%) percent of the Contract Price issued by a bond company acceptable to the HRSB, to continue in force for one (1) year after substantial completion of the Services, covering the performance of all obligations of the Contractor and all warranties of the Contractor under this Agreement.  *Required*       *Not Required*

## WARRANTY

**Warranty:** The Contractor hereby warrants that:

it shall correct promptly, at Contractor's sole expense, defects or deficiencies in the Services as a result of workmanship or materials, which appear prior to the first (1<sup>st</sup>) anniversary of the date of completion of the Services, or such longer periods as may be specified for certain products or work in Appendix "C"; and

during the construction and warranty periods, defects or deficiencies in the Services, causing an emergency condition on the Lands or premises requiring immediate remedial/emergency repairs, outside of normal working hours, will be responded to by the HRSB's operations or maintenance staff. Costs for this emergency response will be the responsibility of the Contractor, and Contractor is hereby liable to indemnify HRSB for all such costs.

## CONFIDENTIALITY AND OWNERSHIP OF WORK PRODUCT

**Confidentiality:** Contractor shall:

not make use of any HRSB Confidential Information for its own personal gain or for any purpose other than is required to provide the Services;

not disclose any HRSB Confidential Information to any person except employees, consultants, subcontractors and agents who have a need to know such information consistent with the provision of the Services, but only after such person has properly assumed obligations identical in principle to those in this Section and Contractor ensures that such person at all times complies with those obligations

employ diligent efforts and exercise reasonable care to hold all HRSB Confidential Information in the strictest confidence;

not use HRSB's name for any marketing or promotional purposes and not make any public announcements or disclosure in respect of this Agreement or Contractor's relationship with HRSB without first obtaining written consent from HRSB; and

be liable to HRSB and indemnify HRSB for any breach of this Section by Contractor or its employees, consultants, subcontractors or agents.

**Terms of Agreements:** Neither party shall disclose the terms of this Agreement or amounts paid under it to any person without the other party's written consent, except to a party's employees, professional advisors and insurers who have a need to know such information, but only where the party ensures that such persons are under obligations of confidentiality identical in principle to those in this Section. HRSB shall not disclose Contractor's information respecting pricing or any information supplied by Contractor that is clearly marked "Confidential" to any person except HRSB's employees, consultants, subcontractors and agents who have a need to know such information.

**"HRSB Confidential Information"** refers to any and all information, material and data disclosed to Contractor by HRSB, or obtained by Contractor in connection with providing the Services, directly or indirectly, orally, in any written form, or in any magnetically or electronically recorded form, or by drawings or inspection of parts or equipment, and including but not limited to: (i) information, knowledge or data of an intellectual, technical, scientific, commercial or industrial nature, or of a financial, cost, pricing, or marketing nature relating to the business operations of HRSB; or (ii) any information supplied by HRSB that is clearly marked "Confidential"; but shall not include information in the public domain or information that at the time of disclosure was already known to Contractor on a non-confidential basis.

**Ownership of Work Product:** All property and intellectual property rights in all reports, designs, drawings, studies, specifications, software, materials, inventions and other work product created, produced or arising in connection with the performance of the Services, whether completed or in progress, and regardless of who was involved therewith, shall be owned exclusively by HRSB and either delivered to HRSB or made available for inspection by HRSB. HRSB's ownership of and title to the foregoing shall arise automatically upon its creation and not be subject to the payment of the Contract Price to Contractor. To the extent Contractor has any title to the foregoing, Contractor shall take and cause to be taken all necessary steps (including a waiver of any moral rights) to transfer title thereto to HRSB.

**Survival:** The provisions of this Article shall survive the expiration or termination of this Agreement.

## MISCELLANEOUS PROVISIONS

**Notices:** Communications in writing between the parties shall be considered to have been received by the addressee on the date of delivery if delivered by hand or by facsimile, or if sent by post, to have been delivered within FOUR (4) business days of the date of mailing, when addressed to the addresses in Appendix "C":

**Assignment:** This Agreement is not assignable by Contractor without the prior written consent of HRSB, which consent may be withheld arbitrarily. Any purported assignment by Contractor of any of its rights, duties, or obligations under this Agreement without HRSB's written consent, shall be voidable by HRSB at its option. Contractor shall not in any event be released from its duties and obligations under this Agreement. HRSB may assign this Agreement upon providing notice to without obtaining Contractor's consent.

**Binding Effect:** This Agreement shall be binding upon and enure to the benefit of each of HRSB and Contractor and their respective successors and permitted assigns.

**Interpretation:** In this Agreement, all references to 'dollars' or '\$' are to Canadian dollars unless stated otherwise. The insertion of headings is solely for convenience of reference and shall not affect the interpretation of any provision.

**Independent Contractor:** The parties agree that Contractor is an independent contractor, that nothing in this Agreement shall be construed as establishing or implying a relationship of master and servant between the parties, or any joint venture or partnership between the parties, and that nothing in this Agreement shall be deemed to constitute either of the parties as the agent of the other party or authorize either party to incur any expenses on behalf of the other party or to commit the other party in any way whatsoever. Contractor and its servants, agents or employees shall at no time be deemed to be servants, agents or employees of HRSB, or be deemed to be under the control or supervision of HRSB when carrying out the Services. Without the prior written consent of HRSB.

**No waiver:** No party shall be deemed to have waived the exercise of any right that it holds under this Agreement unless such waiver is made in writing. No waiver made with respect to any instance involving the exercise of any such right shall be deemed to be a waiver with respect to any other instance involving the exercise of that right or with respect to any other right.

**Governing Law:** This Agreement shall be governed by and interpreted in accordance with the laws of the Province of Nova Scotia and the laws of Canada applicable therein, excluding any conflict of laws rules that may apply therein. The parties hereby attorn to the non-exclusive jurisdiction of the courts of the Province of Nova Scotia, without prejudice to the rights of HRSB to take proceedings in any other jurisdiction. The parties hereby waive any right to a trial by jury.

**Time of the Essence:** Time shall be of the essence in this Agreement.

**Set-Off:** HRSB shall be entitled at all times to set off any amount owing from Contractor to HRSB against any amount due or owing to Contractor with respect to this Agreement.

**Entire Agreement; Invoice Terms of No Effect:** This Agreement constitutes the entire agreement of the parties concerning its subject matter and no other representation, warranties or agreements, either oral or written, shall be binding upon HRSB or Contractor. This Agreement supercedes and invalidates all prior agreements, understandings, negotiations, representations and warranties, whether oral or written, with respect thereto. The terms of this Agreement shall supersede any terms attached to Contractor's invoice, which terms shall not be applicable to this Agreement and shall not be considered to be Contractor's exceptions to the provisions of this Agreement.

**Counterparts:** The parties may execute this Agreement by facsimile or other electronic means and in separate counterparts each of which when so executed and delivered shall be an original, and all such counterparts taken together shall constitute one instrument.

## APPENDIX "B"

### RISK MANAGEMENT AND SAFETY

#### A. INDEMNIFICATION AND INSURANCE

##### 1. **Indemnity and Waiver:**

Contractor shall be liable to HRSB for and shall indemnify and save harmless HRSB from and against any and all claims, suits, demands, awards, actions, proceedings, losses, judgments, costs, damages, settlements or expenses (including legal costs on a solicitor and own client basis) suffered or incurred by HRSB that arise out of, result from, are based upon or are in any way connected with this Contract, including without limitation:

- (a) those resulting from any act or omission on the part of Contractor or its employees, agents and subcontractors;
- (b) those resulting from any action, suit or proceeding brought by any third party;
- (c) those brought in respect of personal injury (including injury resulting in death) or damage or destruction of tangible or intangible property, including HRSB's property;
- (d) those made under workers' compensation legislation;
- (e) those legal costs and fines resulting from the failure of Contractor, its employees, agents or subcontractors to comply with any applicable laws, regulations, by-laws, rules or orders of any government, authority or body having jurisdiction, whether identified in this Contract or applicable by-law;
- (f) those resulting from the release, discharge, seepage or other escape of any substance including chemicals, hazardous or toxic materials, substances, pollutants, contaminants or wastes, whether liquid, gaseous or of any other nature or for any breach of any applicable environmental legislation;
- (g) those resulting from any labourers', materialmen's, or mechanics' liens arising from or relating to the performance of the Contract;
- (h) those brought for actual, alleged, direct or contributory infringement of any patent, trademark, copyright, trade secret or other intellectual property right, including breach of obligations of confidentiality; and
- (i) any other claims, expenses, costs, and losses suffered, incurred or sustained by HRSB.

The foregoing liability, indemnification and hold harmless provisions shall apply to anything done or not done in connection with this Contract and by whomsoever made, regardless of whether it was caused by the negligence of Contractor or otherwise.

Contractor shall make no claim or demand against HRSB for any injury (including death), claim, expense, loss or damage to property suffered or sustained by Contractor or any other person which arises out of, or is connected, with this Contract or anything done or not done as required hereunder, or any other errors or omissions of Contractor, and hereby waives as against HRSB all such claims and demands.

The foregoing indemnity and waiver given by Contractor shall not apply to the extent of HRSB's own negligence. The onus of establishing that HRSB was negligent shall be upon Contractor. HRSB shall not be deemed to have caused or contributed thereto merely by reason of its knowledge, approval or acceptance of the materials, drawings,



specifications, supplies, equipment, procedures or services of Contractor.

For the purposes of this Section, any reference to "HRSB" shall include HRSB, together with the employees, directors, officers, superintendents, trustees, representatives and agents of HRSB; and any reference to "Contractor" shall include Contractor's directors, officers, employees, affiliates, representatives, agents and subcontractors.

## 2. Insurance:

Contractor shall, at its own expense, obtain and maintain during the term of this Contract, in a form and with an insurance company satisfactory to HRSB, policies of:

- (a) Commercial General Liability insurance with a limit of not less than Two Million Dollars (**\$5,000,000**) for any one loss or occurrence and in the aggregate with respect to bodily injury, personal injury and property damage, including loss of use thereof, which policy shall by its wording or by endorsement:
  - (i) include HRSB, its officers, directors, employees, agents and trustees as an additional insured with respect to the obligations assumed by Contractor under this Contract;
  - (ii) provide that, in relation to the interests of each additional insured, the Insurance shall not be invalidated by an action or inaction any other person other than the respective additional insured;
  - (iii) include a "cross liability" clause which shall have the effect of insuring each entity named in the policy as an insured in the same manner and to the same extent as if a separate policy had been issued to each;
  - (iv) extend to cover blanket Contractual liability, including the insurable liabilities assumed by Contractor under this Contract;
  - (v) extend to cover products and completed operations; such products and completed operations coverage, whether by specific policy endorsement respecting the services or by renewal of any annual practice policy, shall be kept in force during the supply of services and for a further period of 24 months following completion of supply of the services;
  - (vi) extend to cover non-owned auto liability coverage; and
  - (vii) not exclude any existing property of HRSB, but shall treat same as "third party property".
- (b) Employer's Liability Coverage which shall not be less than \$5,000,000 for each employee where Workers' Compensation coverage does not exist or the profession/trade has been indicated to be exempted from Workers' Compensation coverage.
- (c) Automobile public liability and property damage insurance in an amount not less than Two Million Dollars (\$2,000,000) all inclusive covering the ownership, use and operation of any motor vehicles and trailers which are owned, leased or controlled by the Contractor and used in connection with this Contract; and
- (d) Property "All Risks" insurance covering Contractor's owned property, including Contractor's equipment, where applicable, and property of others in the care, custody, or control of Contractor or for which the Contractor has assumed liability, all including while in transit or storage, on a replacement cost basis. With respect to any property of HRSB, such policy shall contain a loss payee

clause in favour of HRSB;  
(collectively, the "Insurance").

Contractor shall ensure that the above Insurance policies:

- (a) are endorsed to provide HRSB with not less than thirty (30) days written notice in advance of cancellation, change or amendments restricting coverage;
- (b) do not include a deductible that exceeds such maximum amount that a reasonably prudent business person would consider reasonable; and
- (c) take the form of an occurrence basis policy and not a claims-made policy.

Contractor shall, before any services are performed, provide HRSB with a copy of the certificates of insurance and, if requested by HRSB, the insurance policies evidencing all the coverage stipulated above, and HRSB may withhold payment of any invoice until it receives evidence of such coverage. Failure for any reason to furnish this proof at any time shall be a breach of the contract, allowing the HRSB to terminate the contract or at the HRSB's option, to supply such insurance and charge the cost to Contractor. The HRSB may require Contractor to have the HRSB added as an insured party to the insurance policy and/or require Contractor to furnish a certified copy of the policy for such insurance.

Contractor shall not make or cause to be made any modification, or alteration to the Insurance, nor do or leave anything undone, which may invalidate the Insurance coverage. Contractor shall be responsible for any deductible and excluded loss under the Insurance.

Contractor shall cause all subcontractors performing services to obtain and maintain the Insurance policies required by this Section.

Contractor agrees that the insurance coverage required to be maintained by it under the provisions of this Contract shall in no manner limit or restrict its liabilities under this Contract. HRSB reserves the right to maintain the insurance in good standing at Contractor's expense and to require Contractor to obtain additional insurance where, in HRSB's reasonable opinion, the circumstances so warrant.

## **B. COMPLIANCE WITH LEGISLATION AND REGULATIONS**

### **1. Compliance**

Contractor shall comply with and shall ensure all of its agents, employees and subcontractors comply with all applicable laws and regulations, including all safety, health and environmental requirements pursuant to any government permit, license, or authorization. Contractor shall at its cost obtain all permits and licenses required by any governing authority in order to enable Contractor to provide its goods and services and otherwise perform its obligations under the Contract.

### **2. Labour Code**

Contractor shall comply with all applicable provisions of the *Labour Code* (Nova Scotia) and the *Employment Standards Act* (Nova Scotia) and all regulations and amendments thereto.

### **3. Workers' Compensation Legislation**

Contractor shall comply with the *Worker's Compensation Act* (Nova Scotia) and regulations and amendments thereto, and:

- (a) if any employees perform or assist in the performance of this Contract, the Contractor shall submit, at any time requested by the HRSB, a letter from the Workers' Compensation Board (Nova Scotia) stating that Contractor has an account in good standing with the Worker's Compensation Board;
- (b) the Contractor will make the necessary returns to the Workers' Compensation Board in accordance with government regulations and will pay all fees and contributions required in connection therewith. The cost of compensation will be included in the price payable under the Contract; and
- (c) the Contractor shall submit a clearance from the Workers' Compensation Board that all fees and contributions have been paid before final payment is made by the HRSB under the Contract.

**4. Canada Safety Council and Associated Standards**

All electrical, electronic and gas-fired equipment must bear the required approval markings, being C.S.A. approved for entirely electrical or electronic equipment and C.G.A. or C.S.A. approved for gas fired equipment. All other similar equipment approvals must also be obtained. It shall be the responsibility of the Contractor to obtain all applicable approvals, at its own expense.

**5. Nova Scotia Occupational Health and Safety Legislation**

Contractor shall comply at all times with the Nova Scotia Occupational Health and Safety Act, Regulation and Code, and it's amendments thereto.

**C. SAFETY REQUIREMENTS**

**1. Safety Responsibility**

Contractor shall be solely responsible for ensuring the safety and health of its agents, employees and subcontractors and for ensuring that its activities do not compromise the safety of HRSB's operations. Contractor shall provide to its agents, employees and subcontractors, at its own expense, any and all safety gear required to protect against injuries during the performance of the services and shall ensure that its agents, employees and subcontractors are knowledgeable of and utilize safe practices in the provision of the services, such practices to be at least as stringent as those set out in HRSB's safety standards provided to Contractor from time to time.

**2. Project Site Protection and Safety**

The Contractor shall protect the HRSB's property, staff and students, the Contractor's staff and the public, from damage or injury by providing adequate precautions to make the work site a safe environment at all times. In addition to complying with any safety standards provided to the Contractor by HRSB, the Contractor shall:

- (a) provide all guards and fences and other safety equipment;
- (b) respond to reports of hazards by HRSB;
- (c) do the following when work generating vibration, noise or safety concerns (including without limitation jack hammering, shot blasting, sandblasting, concrete cutting and use of powder actuated fasteners) may affect HRSB property, staff, students or operations.
  - (i) coordinate with HRSB representatives;
  - (ii) schedule and coordinate hours of work with HRSB input; and

- (iii) stop operations generating vibration, noise or safety concerns when instructed by HRSB.
- (d) Contractor responsible to ensure all spaces directly beneath the roof work area are protected from potential damage of dust, debris or water infiltration or any other impact resulting from the roof replacement project. Such protection shall include installation of effective cover using minimum 4 mil plastic vapour barrier sheeting over all furniture, equipment, instruction aids, floors areas and any other items underneath the work space. Contractor must remove all sheeting upon completion of work and will be responsible for costs of restoration of damages caused by process of roof project or lack of adequate protection of property.

### 3. Hazardous Materials

The Contractor shall:

- (a) develop and implement a written "Hazardous Materials Information" document to ensure that all persons at the work site are made aware of the existence of any hazardous materials such as asbestos, lead-based products, and PCB's;

### D. CONTRACTOR EVALUATION

#### 1. Audit

The HRSB reserves the right to audit Contractors and their subcontractor's health and safety performances during the term of the Contract and upon its conclusion.

#### 2. Evaluation

The HRSB reserves the right to evaluate the performance of the Contractor and such evaluation will be based upon accident/injury data and adherence to this Schedule "C", the HRSB health and safety policies, applicable legislation, and periodic inspections and reports from HRSB employees. Information collected as part of such evaluations may be used for future reference.

### E. HRSB REMEDIES FOR CONTRACTOR NON-COMPLIANCE

#### 1. Emergency Work Stoppage

The HRSB has the authority to stop progress of the work whenever, in its opinion, such stoppage is desirable for any safety-related reason. The Contractor hereby agrees that no claim for loss of time or materials may be made with respect to such stoppage unless the claim for the time and materials and their value are certified in writing by the HRSB as allowable.

#### 2. Termination for Non-Compliance

HRSB may terminate this Contract for non-compliance with health, safety, environmental and other applicable legislation and good industry practice on the part of the Contractor or any subcontractor of the Contractor, as constituting a material breach of this Contract. In addition, the HRSB reserves the right to stop the work of the Contractor in the event of Contractor's non-compliance with applicable legislation or good industry practice. Such work stoppages shall not postpone any agreed to completion dates and any additional cost

resulting from such work stoppages shall be borne by the Contractor. Work shall not resume until the Contractor rectifies the reason for non-compliance, to HRSB's satisfaction.

**3. Non-Exclusive Remedies**

Contractor acknowledges and agrees that the foregoing remedies available to HRSB are non-exclusive to, and may be exercised in conjunction with, any other rights or remedies available to HRSB, under the Contract, at law or in equity, in the event of threatened or actual breach of this Contract, including injunctive relief.

SAMPLE ONLY

**APPENDIX "C"**

**DESCRIPTION OF SERVICES**

- Description of Services to be performed by Contractor**, including any applicable standards of performance:

**Description of Work:**

**As per Tender #      drawings, specifications and scope of work**

- Municipal and Legal Description of the Lands:**

**Location of Work**

- Term:** completion of work by ,

- Invoicing:** Services are to be paid for by HRSB:

- By scheduled progress payments (as agreed by both parties)
- By single invoice upon project completion

- Holdbacks:** In compliance with “Section 13 – Holdbacks” of the *Builder’s Lien Act of Nova Scotia (incl. amendments)*, a holdback in the amount of ten percent (10%) of the contract may be held up to ninety (90) days after completion of the work, to the satisfaction of the Board.

- HRSB Project Manager /Contractor Contact Information:**

<p><b>CONTRACTOR INFORMATION</b></p> <p>Name:</p> <p>Jurisdiction of incorporation:</p> <p>Address:</p> <p>Attention:</p> <p>Telephone:</p> <p>Facsimile:</p> <p>E-mail:</p> <p>GST Registration #:</p> <p>WCB Registration #:</p>	<p><b>HRSB INFORMATION</b></p> <p>HRSB Representatives:</p> <p>Name:</p> <p>Department: <b>Operations Services</b></p> <p>Address:      <b>33 Spectacle Lake Drive</b>  <b>Dartmouth, N.S., B3B 1X7</b></p> <p>Telephone:    <b>902 464-2000 Ext.</b></p> <p>Facsimile:    <b>902-</b></p> <p>E-mail:</p>

SAMPLE ONLY

\_\_\_\_\_  
 Contractor's Initials      HRSB's Initials

**Exhibit A**

**Invitation To Tender**

**PROJECT SPECIFICATIONS/DRAWINGS WERE INCLUDED IN TENDER DOCUMENT AND ARE CONSIDERED PART OF THIS CONTRACT EVEN THOUGH THEY ARE NOT ATTACHED TO THIS DOCUMENT**

**Exhibit B**

**Response to Invitation to Tender**

**A COPY OF THE SUCCESSFUL CONTRACTOR'S BID SUBMISSION IS ON FILE IN  
THE PURCHASING DEPARTMENT - TENDER #3437**



**APPENDIX "D"**

**UNDERTAKING TO COMPLY FORM  
AND CONTRACTOR SAFETY CHECKLIST**

**UNDERTAKING TO COMPLY**

**Name of Contractor:**

**(the "Contractor")**

**Description of Agreement:**

**Site Location:**

**(the "Agreement")**

7. The Contractor hereby undertakes to HRSB:  
to comply with all health, safety and environmental legislation in the performance of this Agreement; and  
to maintain a safe and healthy work environment during the performance of this Agreement.
8. The Contractor hereby agrees with HRSB:  
that compliance with all health, safety and environmental legislation is a condition of this Agreement and that non-compliance with the same may, in HRSB's discretion, lead to the termination of this Agreement; and  
to permit HRSB to audit the Contractor's health, safety and environmental records during the term of this Agreement and upon its conclusion and to cooperate fully with any such audit(s).
9. The Contractor understands that, at HRSB's discretion, any Contractor safety deficiencies will be addressed by HRSB in the following progressive steps:  
the problems will be identified to the Contractor (site supervisor);  
the Contractor's head office will be contacted about the problem, orally and later in writing;  
if required by law to report the problem to a Provincial and or Federal Ministry, HRSB will immediately do so;  
if not required by law to report the problem, and the problem remains unresolved, HRSB may report the problem; and  
the Agreement may, in HRSB's discretion, be suspended or terminated and/or payment withheld by HRSB.

- 10. The Contractor acknowledges and agrees with HRSB that, depending upon the nature and/or seriousness of the deficiency, HRSB reserves the right to bypass any or all of the steps described in Section 3.
- 11. **Prime Contractor Designation:** The Contractor and the HRSB hereby agree that the Contractor shall, pursuant to Section 8.4 of the Agreement shall be the Prime Contractor.

The undersigned hereby confirms that he/she has the authority to bind the Contractor:

**CONTRACTOR**

**HALIFAX REGIONAL  
SCHOOL BOARD**

\_\_\_\_\_  
*FULL COMPANY NAME*

\_\_\_\_\_  
*PRINT NAME*

\_\_\_\_\_  
*AUTHORIZED SIGNATURE*

\_\_\_\_\_  
*POSITION*

\_\_\_\_\_  
*DATE*

\_\_\_\_\_  
*PRINT NAME*

\_\_\_\_\_  
*AUTHORIZED SIGNATURE*

\_\_\_\_\_  
*POSITION*

\_\_\_\_\_  
*DATE*

SAMPLE ONLY

**PRE-CONSTRUCTION MEETING**  
**CONTRACTOR SAFETY CHECKLIST PAGE 1**

MEETING DATE:	TENDER #:
---------------	-----------

SITE LOCATION:
----------------

COMPANY NAME:
---------------

CONTRACTOR REPRESENTATIVE::
-----------------------------

HRSB REPRESENTATIVE::
-----------------------

√ Means complied to	X Means not complied with	n/a means not applicable
---------------------	---------------------------	--------------------------

- |  |   |  |
|--|---|--|
| <p>1. Notice of Project filed with Nova Scotia Infrastructure (if applicable) <input type="checkbox"/></p> <p>2. Review Board Safety Compliance Undertaking to Comply Form Signed <input type="checkbox"/></p> <p>Progressive Disciplinary Action Reviewed <input type="checkbox"/></p> <p>3. Contractor Health and Safety Policy <input type="checkbox"/></p> <p>Prime Contractor and Safety Management Certificate <input type="checkbox"/></p> <p>4. Health &amp; Safety Representatives/Joint Site Health &amp; Safety Committee <input type="checkbox"/></p> <p>Name and Phone _____</p> <p>5. Personal Protective Equipment:</p> <p>Hard Hats <input type="checkbox"/></p> <p>Footwear <input type="checkbox"/></p> <p>Safety Glasses <input type="checkbox"/></p> | <p>8.</p> <p>9.</p> <p>10.</p> <p>11.</p> | <p>Contractor Staff Training: Emergency Response <input type="checkbox"/></p> <p>WHMIS Training Verification <input type="checkbox"/></p> <p>O H &amp; S <input type="checkbox"/></p> <p>MSDS Received <input type="checkbox"/></p> <p>Scaffold <input type="checkbox"/></p> <p>Confined Space Code of Practice <input type="checkbox"/></p> <p>TDG Training Verification <input type="checkbox"/></p> <p>Working Alone <input type="checkbox"/></p> <p>Review Contractor Signage &amp; Barricades <input type="checkbox"/></p> <p>Written Work Site Hazard Assessment and Control Plan/Schedule Submitted <input type="checkbox"/></p> <p>Building Fire Plan <input type="checkbox"/></p> |
|--|---|--|

SAMPLE ONLY

**CONTRACTOR SAFETY CHECKLIST – PAGE 2**

- |   |                          |   |                          |
|---|--------------------------|---|--------------------------|
| Hearing   | <input type="checkbox"/> | 12. Accident Investigation/Notification/Reporting Procedure | <input type="checkbox"/> |
| Dust & Fumes  | <input type="checkbox"/> |   |                          |
| Face Protection   | <input type="checkbox"/> |   |                          |
| Others: _____   | <input type="checkbox"/> | 13. Contingency Plan for Control & Clean up of a Spill      | <input type="checkbox"/> |
| _____   | <input type="checkbox"/> |   |                          |
| _____   | <input type="checkbox"/> | 14. Heating Coil/Extinguishers                              | <input type="checkbox"/> |
|   |                          |   |                          |
| 6. Equipment Certification  |                          | 15. First Aid Kits on Site                                  | <input type="checkbox"/> |
| Trench Boxes  | <input type="checkbox"/> |   |                          |
|   |                          | 16. First Aiders on Staff                                   | <input type="checkbox"/> |
| Boom Cranes   | <input type="checkbox"/> | Names: _____  |                          |
| Scaffolds   | <input type="checkbox"/> |   |                          |
| Others: _____   | <input type="checkbox"/> | 17. Fall Protection /Safety Harness                         | <input type="checkbox"/> |
| _____   | <input type="checkbox"/> |   |                          |
| _____   | <input type="checkbox"/> | 18. Methane gas Detection in Sewer                          | <input type="checkbox"/> |
|   |                          |   |                          |
| 7. Provision of Hazardous Material Information to Contract                      | <input type="checkbox"/> | 19. Clean Up - Good Housekeeping                            | <input type="checkbox"/> |
| Confirmation of Employee Awareness of Hazardous Material                        | <input type="checkbox"/> |   |                          |
| Asbestos  | <input type="checkbox"/> | 20. Weekly Safety Talks/Meetings                            | <input type="checkbox"/> |
| Lead  | <input type="checkbox"/> |   |                          |
| PCB   |                          |   |                          |
| Confirmation that Prime Contractor reviewed Asbestos Inventory at the work site | <input type="checkbox"/> | 21. Other Issues  | <input type="checkbox"/> |

SAMPLE ONLY





## APPENDIX E

### **Project Safety Plan Outline**

During the planning of each project, environmental and occupational health and safety issues will be assessed like any other key project component.

Prior to beginning a new project, tendering Contractors shall examine the work area to identify potentially hazardous site specific situations.

Once identified, these hazards should be prioritized on this Hazard Assessments/Project Safety Plan Outline and corrective *actions* noted to eliminate or control each hazard. The dates of when and names of the persons who are responsible for completing the *action* should also be assigned.

Copies of the completed Safety Plan Outline shall be submitted as part of the tender document submittal, sent to the HRSB Operations Services Regional Manager, made available on the job site and communicated to the workers.

---

---

Project Name: \_\_\_\_\_

Project Location: \_\_\_\_\_

Project Start date: \_\_\_\_\_

Project End date: \_\_\_\_\_

Company Name: \_\_\_\_\_

Completed by: \_\_\_\_\_  
(Contractor's project manager)

Date: \_\_\_\_\_

Copy to: \_\_\_\_\_

**PLANNING:**

Does the Contractor's Occupational Health and Safety Program deal with the work activities associated with this project?    Yes                       No

Describe tasks to be undertaken: \_\_\_\_\_  
\_\_\_\_\_  
\_\_\_\_\_  
\_\_\_\_\_

**HAZARDS ASSESSMENT:**

Identify the hazards that could present themselves on this project (e.g. live electrical wires, over water, confined space, etc) and describe what steps will be taken to prevent an incident (e.g. cover up, de-energize, safe work practices, netting, etc). Prioritize from #1 as needing immediate action.

#	Hazard	Required Action	Completed by	Date
1				
2				
3				
4				
5				
6				
7				
8				
9				
10				

**ENVIRONMENTAL ASSESSMENT:**

Identify the environmental issues that could present themselves on this project (e.g. oil spills, asbestos, etc.) and describe the action that will be taken to eliminate or reduce the risk of occurrence (e.g. mop kits, air sampling, etc.)

#	Hazard	Required Action	Completed by	Date
1				
2				
3				
4				
5				

**EMERGENCY RESPONSE:**

In the event of an incident, pre-plan the response and write up the procedures. Minimally, the following list should be completed and posted on site:

Contact	Phone #	Contact	Phone #
Fire	911	Poison Control	428-8161
Ambulance	911	Dangerous Goods	1-800-565-1633
Doctor	911	Waste Disposal	
Police	911	Insurance	
HRSB Office	493-5110	Min/Dept of Labour	1-800-952-2687
Min./Dept.of Transport.		Min/Dept of Environment	1-800-565-1633

- Identify and arrange source of first aid, ambulance and rescue.
- Accidents will be reported to: \_\_\_\_\_
- Accidents will be investigated by: \_\_\_\_\_
- Back-up call to: \_\_\_\_\_
- HRSB # emergency/after hours: day 493-5110 after 4:00 pm 442-2476



**SAFETY MEETINGS:**

On this project, given the nature of the work and the anticipated size of the work force, the following frequency will apply:

Site meetings \_\_\_\_\_

Site Audits \_\_\_\_\_

Follow up with HRSB Manager: \_\_\_\_\_

**SITE IMPLEMENTATION:**

- Health and Safety Rep & Safety Committee:  
Establish liaison between HRSB, Contractor, site administration  
First Aid, PPE, other safety items as required.
  
- Documentation:  
Applicable MSDS  
Safety program  
Applicable work procedures  
Permits  
First Aid Certification

**TRAINING:**

The following training/testing will be mandatory on site:

1) \_\_\_\_\_

\_\_\_\_\_

2) \_\_\_\_\_

\_\_\_\_\_

3) \_\_\_\_\_

\_\_\_\_\_

**TENTATIVE SCHEDULE OF WORK:**

- 1) Date Project Will Commence: \_\_\_\_\_
- 2) Number of Weeks to Complete Project: \_\_\_\_\_ weeks
- 3) Expected Completion Date: \_\_\_\_\_

***NOTE:***

***Within five (3) business days the successful bidder shall provide a schedule clearly indicating timelines for completion of all aspects of the project.***

## **APPENDIX F**

### ***CONTRACTOR'S CHECKLIST***

Enclose the following documents with your bid:

- Bid Security as required in Clause 1.3 (e)*** in the amount of 10% of the Contract Price (before HST).
- Contract Security for bids over \$100,000 as required in Clause 1.3 (f)***.
- Certificate of Insurance*** indicating a minimum of **\$5,000,000 Commercial General Liability Insurance** per occurrence and **Commercial Auto Liability Insurance** covering all owned, non-owned and hired vehicles for a minimum combined single limit of **\$2,000,000** per occurrence and **Builder's Risk Insurance** in the amount of the contract price.
- Tentative Work Schedule (Timelines)*** – Subsequently, within five (5) business days of tender award the successful bidder shall provide a schedule clearly indicating timelines for completion of all aspects of the project.
- Workers' Compensation Board Letter*** of Good Standing
- Certificate of Recognition from one of the seven safety audit companies that jointly sign with the WCB:***
  - East Coast Mobile Medical Inc.
  - HSE Integrated
  - Nova Scotia Construction Safety Association
  - Nova Scotia Trucking Safety Association
  - Occupational Health & Educational Services (2002) Inc.
  - Safety Services Nova Scotia
  - Stantec Inc.

This list can be found on WCB's website: [www.wcb.ns.ca](http://www.wcb.ns.ca).
- Completed HRSB Safety Plan***
- Applicable Warranty Information***

	No. of Pages
<b>Division 21 COMMON MECHANICAL WORKS</b>	
21 05 01 Mechanical General Requirements	7
21 05 02 Mechanical Submittals	5
21 05 03 Mechanical Contract Closeout	2
21 05 04 Firestopping for Mechanical	5
<b>Division 23 HYDRONIC</b>	
23 05 19 Thermometers and Pressure Gauges	2
23 05 23 Valves	3
23 05 29 Hangers and Supports	3
23 05 53 Mechanical Identification	4
23 07 00 Mechanical Thermal Insulation	6
23 21 13 Hydronic Systems	4
23 21 14 Hydronic Specialties	4
23 21 23 Hydronic Pumps	2
23 25 00 HVAC Water Treatment	2
<b>Division 24 AIR DISTRIBUTION</b>	
24 05 93 Balancing Mechanical Systems	5
24 31 13 Low Pressure Ducts to 500 Pa	4
24 55 01 Coils	1
<b>Division 25 INTEGRATED AUTOMATION</b>	
25 01 11 BAS: Start-Up Verification	4
25 05 01 BAS: General Requirements	8
25 05 02 BAS: Submittals	4
25 05 03 BAS: Identification	5
25 30 01 BAS: Building Controllers	7
25 30 02 BAS: Field Control Devices	5
25 30 03 BAS: Field Installation	13

**ARCHITECTURAL**

A-1 Ceiling Removal and Reinstallation

**MECHANICAL**

MH101 LEGEND AND FLOOR PLANS - HEATING

MH401 HYDRONIC SCHEMATIC AND PARTIAL FLOOR PLANS

MH501 HYDRONIC DETAILS AND SCHEDULES

MV101 AIR DISTRIBUTION FLOOR PLANS AND SECTIONS

MC601 CONTROLS

MC602 CONTROLS

**ELECTRICAL**

EP101 PARTIAL FLOOR PLANS, POWER, MECH CONN. ELEC. LEGEND,  
SPECIFICATIONS MOTOR STARTER AND CONTROL LIST

**END OF SECTION**

## **1      General**

### **1.1    GENERAL**

- .1      The General Conditions of the contract as well as provisions of Division 1 are part of and to be read in conjunction with this Section.
- .2      This section covers items common to all sections of Division 21, 22, 23, 24 and 25.

### **1.2    RELATED SECTIONS THAT ARE PART OF DIVISION 21 TO 25 WORK**

- .1      Section 25 01 11 BAS: Start-Up and Verification
- .2      Section 25 05 01 BAS: General Requirements
- .3      Section 25 05 02 BAS: Submittals
- .4      Section 25 30 01 BAS: Building Controllers
- .5      Section 25 30 02 BAS: Field Control Devices
- .6      Section 25 30 03 BAS Field Wire and Components Installation

### **1.3    INTENT**

- .1      It is the intent of these specifications to outline the method, materials, and quality of equipment to be furnished and installed hereinafter specified and/or shown on the drawings.
- .2      The Mechanical Contractor shall be responsible for the installation of all equipment, materials, and accessories, and the labour required for the completion of this contract to the full satisfaction and acceptance of the Consultant. Misinterpretation of either the drawings or the specifications will not relieve the Contractor of responsibility.

### **1.4    DEFINITIONS**

- .1      "CONCEALED" - mechanical services and equipment in hung ceiling spaces and non-accessible chases and furred spaces.
- .2      "EXPOSED" - will mean "not concealed" as defined herein.
- .3      "Domestic Water" includes domestic cold water, domestic hot water, tempered hot water and domestic hot water recirculation.
- .4      "Hydronic" includes hot water heating and glycol supply and return piping.
- .5      "Provide" will mean "Supply and install".

### **1.5    REFERENCE STANDARDS**

- .1      The most stringent requirements of local municipal by-laws, provincial codes and following codes and standards shall be followed.

- .2 In no instance shall the Standard established by the contract documents be reduced by the application of any other codes.
- .3 General
  - .1 National Building Code of Canada - 2010.
  - .2 National Fire Code of Canada - 2010.
  - .3 ARI 410 Forced Circulation Air Cooling and Air Heating Coils.
  - .4 ASTM A653/A653M - 09a Standard Specification for Steel Sheet, Zinc-Coated (Galvanized) or Zinc-Iron Alloy-Coated (Galvannealed) by the Hot-Dip Process
  - .5 SMACNA HVAC Duct Construction Standards - Metal and Flexible, 3rd Edition, 2005.

## **1.6 EQUIPMENT INSTALLATION**

- .1 Unions or flanges: provide for ease of maintenance and disassembly.
- .2 Space for servicing, disassembly and removal of equipment and components: provide as recommended by manufacturer or as indicated.

## **1.7 ANCHOR BOLTS AND TEMPLATES**

- .1 Supply anchor bolts and templates for installation by other divisions.

## **1.8 ELECTRICAL**

- .1 Electrical work to conform to Electrical Contract including the following:
  - .1 Supplier and installer responsibility is indicated in Motor, Control and Equipment Schedule on electrical drawings and related mechanical responsibility is indicated on Mechanical Equipment Schedule on mechanical drawings.
  - .2 Control wiring and conduit is specified in Electrical Contract except for conduit, wiring and connections which are related to mechanical control systems specified in Mechanical Contractor. Refer to Electrical Contract for quality of materials and workmanship.
- .2 Coordinate with Electrical Contractor to ensure that all controlled equipment is correctly connected for operation in accordance with plans and specifications, including supplying all necessary electrical interconnection information and location to Electrical Contractor.

## **1.9 EXISTING SYSTEMS**

- .1 Connections into existing systems to be made at time approved by Consultant. Request written approval of time when connections can be made.
- .2 Be responsible for damage to existing plant by this work.
- .3 Ensure that all plumbing, heating, ventilation and other mechanical systems and services remain operational during the course of the renovation of the existing building and, if necessary, this Contractor shall be responsible for providing such temporary services by cutting off, altering, adapting, relocating and connecting existing services and disconnecting and removing such temporary or existing services upon providing new permanent services as detailed on all drawings. The site shall be examined to determine the extent of the temporary services and all co-ordination shall be made with the Owner's Representative. All costs shall be included in the Tender Price.

- .4 Existing equipment, piping, ducting, etc. not being re-used under new schemes, shall be removed whether shown on drawings or not. The General Contractor shall repair all openings resulting from the removal of existing mechanical equipment and services. All costs shall be included in the Tender Price.

## **1.10 CUTTING AND PATCHING**

- .1 Refer to Division 1.

## **1.11 DRAWINGS**

- .1 The drawings accompanying this specification are to be considered as diagrammatic only and do not show all the structural and construction details. Any information involving measurements of the building shall be taken from the architectural and structural drawings, and at the building site. Make without additional charge any necessary changes or additions to the runs to accommodate structural conditions.
- .2 The Mechanical drawings are not to be scaled.
- .3 The drawings and the specifications shall be considered an integral part of the contract documents. Neither the drawings nor the specifications shall be used alone. Misinterpretation of any requirements of either plans or specifications shall not change the requirements of the specifications for proper completion of the work to the full approval of the Consultant.
- .4 Except where dimensioned, indicate general Mechanical layouts only. Because of the small scale of Mechanical drawings, it is not possible to show all offsets, fittings and accessories which may be required. Investigate structural and finish conditions affecting this work and arrange work accordingly, providing such fittings, valves and accessories which are required to meet the conditions.
- .5 The drawings indicate the general location and route to be followed by the pipes, ducts, conduits, etc., which are installed under this contract. Where the required conduit work, piping, ductwork, etc., is not shown on the plans or only shown diagrammatically, these shall be installed as tight as possible to structural members, concrete, ceilings, and walls to interfere as little as possible with the free use of the space through which they pass.
- .6 The drawings and specifications are intended to supplement each other so that any details shown on the drawings are not mentioned in the specifications, or vice versa, shall be executed in the same manner as if contained in the specifications and shown on the drawings.
- .7 Should any discrepancy appear between these specifications and the drawings to cause doubt as to the true meaning and intent of the drawings and specifications, a ruling shall be obtained from the Consultant before submitting the tender. If this is not done it will be assumed that the more expensive alternative has been included in the contract.
- .8 Layouts on the Mechanical drawings are based on the specified equipment, including mechanical and electrical connections and physical dimensions. Alternate equipment and systems proposed by the Contractor for use on this project, which necessitates changes in service connections to perform the specified functions may be considered by the Consultant, however, any required modifications or additions shall be done at no additional cost to the Owner. Furthermore, if it is found that the provisions made regarding space conditions and code required clearances are not met, the right is reserved by the Consultant to require installation of the equipment specified.



## **1.12 CONTRACT DOCUMENTS**

- .1 Before submitting tender for his work, each Contractor shall examine the contract documents (electrical drawings, structural drawings, and architectural drawings and specifications) to ascertain that the work can be carried out as shown on these drawings and herein specified. No extra will subsequently be allowed to cover any omission and/or oversight for not having made a thorough inspection of the contract documents.

## **1.13 EXAMINE THE SITE AND CONDITIONS**

- .1 Each Contractor shall visit and examine the site and the local conditions affecting this work. No allowance will be made later for any expenses occurred through failure to make these examinations.

## **1.14 WASTE MANAGEMENT AND DISPOSAL**

- .1 Separate and recycle waste materials in accordance with the Project Waste Reduction Workplan. Refer to Division 1.
- .2 Place materials defined as hazardous or toxic waste in designated containers.
- .3 Collect and separate plastic, paper packaging and corrugated cardboard in accordance with Project Waste Management Plan

## **1.15 LOW VOC MATERIALS**

- .1 All site applied coatings, adhesives & sealants must conform to low VOC content requirements.
- .2 Provide Material Safety Data Sheets for all products and materials of these types incorporated into the work.

## **2 Products**

### **2.1 MATERIAL**

- .1 For the purpose of uniformity similar materials shall be by one manufacturer.
- .2 Standard of Acceptance and/or Acceptable Material:
  - .1 Means that item named and specified by manufacturer and/or catalogue number forms part of specification and sets standard regarding performance, quality of material and workmanship and when used in conjunction with a referenced standard, shall be deemed to supplement the standard.
- .3 Acceptable Manufacturer:
  - .1 Means that item manufactured by named and specified manufacturer, meeting the specification and referenced standard regarding performance, quality of material and workmanship shall be deemed acceptable.
- .4 Refer to Instructions to Bidders for requirements of additional Acceptable Manufacturers or Acceptable Material.

## **2.2 ELECTRICAL DEVICES AND PANELS.**

- .1 All electrical equipment and devices to be CSA certified and manufactured to standard quoted.
- .2 The assembly of combinations of electrical components, such as, relays, current transformers, BAS devices, transformers, fuse blocks, transducers or other certified components in an enclosure to form an overall electrical assembly shall be CSA certified.
- .3 Where field modifications are made to certified electrical equipment, arrange and pay for field certification by CSA.

## **2.3 MOTORS**

- .1 Provide motors for mechanical equipment as specified.
- .2 If delivery of specified motor will delay delivery or installation of any equipment, install motor approved by Consultant for temporary use. Final acceptance of equipment will not occur until specified motor is installed.
- .3 Motors under 370 Watts (1/2 HP): speed as indicated, continuous duty, built-in overload protection, resilient mount, single phase, 120 V, 60 Hertz, unless otherwise specified or indicated.
- .4 Motors 370 Watts (1/2 HP) and larger: EEMAC Class B, squirrel cage induction, speed as indicated, continuous duty, drip proof, ball bearing, 3 phase, 208 V, 60 Hertz, maximum temperature rise 40° C, unless otherwise specified or indicated.
- .5 Service factor 1.15.

## **2.4 EQUIPMENT SUPPORTS**

- .1 Equipment supports supplied by equipment manufacturer: specified elsewhere in Mechanical Contractor.
- .2 Equipment supports not supplied by equipment manufacturer: fabricate from structural grade steel.
- .3 Exterior supports to be hot dipped galvanized. Touch up field welds and bolt holes with cold galvanized paint

## **2.5 PAINT**

- .1 Apply at least one coat of primer paint to ferrous supports, pipe hangers and site fabricated work.
- .2 Primer to be The Master Painters Institute MPI #23 with VOC < 351 grains/L

## **2.6 PIPE PENETRATION THROUGH WALLS AND FLOOR**

- .1 Do not grout or bond hydronic pipes solid to walls or floors.

- .2 Provide cast in place temporary collar, core drill slab or sleeve all hydronic pipes penetration through floors.
- .3 For all hydronic pipes and control conduits through all masonry walls, provide sleeves. Maintain a minimum uniform 1/4" (6 mm) clearance all around or as required for smoke seal, acoustic seal and/or fire stopping.
- .4 For all hydronic pipes and control conduits through all drywall walls, coordinate with other trades to ensure there is minimum uniform 6 mm clearance all around or as required for smoke seal, acoustic seal and/or fire stopping.
- .5 Ensure no contact between copper tube / pipe and ferrous sleeve or concrete.
- .6 Coat exposed exterior surface of ferrous sleeves with heavy application of zinc rich paint to CAN/CGSB-1.181-92 coating, zinc-rich organic, ready mixed.

## **2.7 PIPE SLEEVES**

- .1 For floors into Mechanical Rooms, provide schedule 40 sleeves with annular fin continuously welded to sleeve. Extend 50 mm above finish floor.
- .2 For floors other rooms, provide 1.6 mm (16 Ga.) galvanized sleeves with retaining tabs, terminating flush with floor.
- .3 For walls, provide 1.6 mm (16 Ga.) galvanized sleeves.

## **2.8 SMOKE SEAL AND/OR ACOUSTIC SEAL**

- .1 Firestop all pipe penetration through fire rated walls and fire rated floor.
  - .1 Refer to Section 21 05 04 Through-Penetration Firestopping for Mechanical Systems
- .2 Where non rated walls extend from floor to floor or floor to roof deck and non-rated floors.
  - .1 Smoke seal and/or acoustic seal all pipes, both sides of wall/floor.
  - .2 Smoke seal and/or acoustic seal between duct and wall, both sides of wall/floor.

## **2.9 FIRESTOPPING**

- .1 Firestopping material and installation within annular space between pipes, ducts, insulation and adjacent fire separation
  - .1 Refer Section 21 05 04 Firestopping for Mechanical Systems for material.
- .2 Uninsulated unheated pipes not subject to movement: no special preparation.
- .3 Uninsulated heated pipes subject to movement: wrap with non-combustible smooth material to permit pipe to move without damaging firestopping material.
- .4 Fire stop both sides of wall.

## **2.10 DRAINS VALVES**

- .1 In accordance with Section 23 05 23 Valves.

## **2.11 HANGERS AND SUPPORTS**

- .1 As per Section 23 05 29 Hangers and Supports.

## **2.12 IDENTIFICATION**

- .1 As per Section 23 05 53 Mechanical Identification.

## **2.13 INSULATION**

- .1 As per Section 23 07 00 Mechanical Thermal Insulation.

## **3 Execution**

### **3.1 INSTALLATION**

- .1 Install all work in accordance with authorities having jurisdiction and manufacturer's requirements. In case of conflicting requirements, the more stringent shall apply.

### **3.2 PROTECTION OF OPENINGS**

- .1 Protect equipment and systems openings from dirt, dust, and other foreign materials with materials appropriate to system.

### **3.3 TESTS**

- .1 Give 4 working days written notice of date for tests.
- .2 Insulate or conceal work only after testing by contractor and review by Consultant.
- .3 Conduct tests in presence of Consultant or representative authorized by the Consultant.
- .4 Bear costs including retesting and making good.
- .5 Hydronic Piping:
  - .1 Maintain test pressure without loss for 4 h unless otherwise specified.
  - .2 Hydraulically test hydronic piping systems at 1 1/2 times system operating pressure or minimum 860 kPa (125 psig), whichever is greater.
- .6 Equipment: test as specified in relevant sections.
- .7 Prior to tests, isolate all equipment or other parts which are not designed to withstand test pressures of test medium.

### **3.4 PAINTING**

- .1 Prime and touch up marred finished paintwork to match original.
- .2 Restore to new condition, finishes which have been damaged too extensively to be merely primed and touched up.

**END OF SECTION**

## 1 General

### 1.1 REFERENCE STANDARDS

- .1 In accordance with Section 21 05 01 Mechanical General Requirements

### 1.2 SHOP DRAWINGS AND PRODUCT DATA

- .1 In accordance with Division 1
- .2 Shop Drawings to be Project Specific
- .3 Prior to submitting shop drawings, the Mechanical Contractor to review the shop drawing to ensure that they meet the requirements of the contract documents in all respects, that they are clear and legible, all options are being provided are clearly indicated and that the dimensions, weights, power requirements, quantities and capacity are consistent with the requirements of the contract documents.
- .4 Assembled in groups and bound in sets.
- .5 On cover/front page indicate total number of pages in submission.
- .6 Consecutively number each page.
- .7 Shop Drawings to list components that are shipped loose.
- .8 Shop Drawings to include **Project Specific** wiring diagrams.
- .9 Attach a Mechanical Contractor's Shop Drawing Review Confirmation to each shop drawing confirming the following:
  - .1 The mechanical shop drawings have been reviewed by the Mechanical Contractor and all items are in conformance with the contract documents  Yes  No
  - .2 Project specific model numbers and/or options are indicated  Yes  No
  - .3 Mechanical Contractor: \_\_\_\_\_
  - .4 Mechanical Contractor Project Representative: \_\_\_\_\_
  - .5 Mechanical Contractor Signature: \_\_\_\_\_
  - .6 Item: \_\_\_\_\_
  - .7 Specification Section and item number: \_\_\_\_\_
  - .8 Drawing reference: \_\_\_\_\_
- .10 Where specified in Division 1, submit electronic copies of shop drawings. In addition to the electronic shop drawing, submit one hard copy to the office of the mechanical consultant.
- .11 Section 21 05 04 Firestopping for Mechanical
  - .1 Submit Product Data: Manufacturer's specifications and technical data for each material including the composition and limitations, documentation of ULC or cUL firestop systems to be used and manufacturer's installation instructions to comply with Division 1.
  - .2 Provide data showing firestopping method for mechanical services including but not limited to the following:

- 
- .1 Cast iron pipe at wall
  - .2 Cast iron pipe at floor.
  - .3 Copper pipe at wall
  - .4 Copper pipe at floor
  - .5 Steel pipe at wall
  - .6 Steel pipe at floor.
  - .7 Other site specific conditions.
- .3 Name of qualified installer.
  - .4 Manufacturer's engineering judgment identification number and drawing details when no ULC or cUL system is available for an application. Consultant judgment must include both project name and contractor's name who will install firestop system as described in drawing.
  - .5 Submit material safety data sheets provided with product delivered to job-site.
- .12 Section 23 05 16 Expansion Fittings.
    - .1 Movement Handled, Axial, lateral, Angular and the Amount of Each.
- .13 Section 23 05 19 Thermometers and Pressure Gauges
    - .1 Direct reading thermometers.
    - .2 Pressure Gauges.
- .14 Section 23 05 23 Valves
    - .1 Circuit Balancing Valves: Provide schedule showing size, flow and pressure drop.
- .15 Section 23 05 29 Hangers and Supports
    - .1 Upper attachments for ducts.
    - .2 Upper attachments for pipes.
    - .3 Pipe hangers
    - .4 Description of where each type of upper attachment and hanger will be utilized
- .16 Section 23 07 00 Mechanical Thermal Insulation
    - .1 Each type of insulation
    - .2 Canvas
- .17 Section 23 21 23 Hydronic Pumps.
    - .1 Pump Performance Curves.
- .18 Section 23 21 13 Hydronic Systems
    - .1 Roll groove coupling and fittings.
- .19 Section 23 21 14 Hydronic Specialties
    - .1 Expansion Tanks.
    - .2 Glycol Pump.
    - .3 Glycol Relief Valve.
- .20 Section 23 25 00 HVAC Water Treatment Systems.
- .21 Section 23 57 00 Heat Exchangers.
- .22 Section 24 55 01 Coils
    - .1 Coils and Coil Performance data.

- .23 Section 25 05 01 BAS: General Requirements.
  - .1 Refer to Section 25 05 02 BAS: Submittals
- .24 Shop drawings and product data shall show:
  - .1 Mounting arrangements.
  - .2 Operating and maintenance clearances, e.g. access door swing spaces.
- .25 Shop drawings and product data shall be accompanied by:
  - .1 Detailed drawings of bases, supports, and anchor bolts.
  - .2 Acoustical sound power data, where applicable.
  - .3 Points of operation on performance curves.
  - .4 Manufacturer to certify as to current model production.
  - .5 Certification of compliance to applicable codes.
  - .6 Wiring diagrams and electrical characteristics specified for unit supplied.

### 1.3 OPERATING AND MAINTENANCE (O&M) MANUAL

- .1 Operating and maintenance manual to be reviewed by the Consultant and final copies deposited with Consultant before application for substantial performance certificate
- .2 Organize by specification section.
- .3 O&M Manuals to be custom designed and contain material pertinent to this project only and to provide full and complete coverage of subjects referred to in this section.
- .4 Customize O&M data from manufacturer's to suit this project.
  - .1 Provide site specific manual or
  - .2 Neatly cross out non applicable generic information in the manual.
  - .3 In Manufacturer's literature, highlight model supplied for this project.
- .5 Conform to requirements of Division 1, supplemented and modified by requirements specified in this section.
- .6 Project records and O&M manuals specified in this section are to be completely separate entity from those specified in Division 1.
- .7 Operation data to include:
  - .1 Control schematics for each system including environmental controls.
  - .2 Description of each system and its controls.
  - .3 Description of operation of each system at various loads together with reset schedules and seasonal variances.
  - .4 Operation instruction for each system and each component.
  - .5 Description of actions to be taken in event of equipment failure.
  - .6 Valves schedule.
  - .7 Color coding chart.
- .8 Maintenance data shall include:
  - .1 Servicing, maintenance, operation and trouble-shooting instructions for each item of equipment.
  - .2 Data to include schedules of tasks, frequency, tools required and task time.

- .9 Submittals:
- .1 Include a copy of all reviewed mechanical shop drawings.
  - .2 Submit a copy of the complete O&M Manual to Consultant for Review.
  - .3 Submission of individual data will not be accepted unless so directed by Consultant.
  - .4 Make changes as required and re-submit as directed by Consultant.
  - .5 Refer to Division 1 for quantity of Manuals (minimum 2).
  - .6 Hard-back, 50 mm (2") 3 ring, D-ring binders.
  - .7 Binders to be 2/3 maximum full.
  - .8 Provide index to full volume in each binder.
  - .9 Identify contents of each manual on cover and spine.
  - .10 Include names, addresses, telephone numbers of each sub-contractor having installed equipment, local representative for each item of equipment, each system.
  - .11 Provide full Table of Contents in each manual. Assemble each manual to conform to Table of Contents with tab sheets placed before instructions covering subject.
- .10 Provide maintenance data for the following:
- .1 Section 23 21 23 Hydronic Pumps.
  - .2 Section 23 57 00 Heat Exchangers.
  - .3 Section 24 73 11 Packaged Air Handling Units
- .11 Prepare and insert into operation and maintenance manual, additional data when need for same becomes apparent during demonstrations and instructions specified above.

#### 1.4 RECORD DRAWINGS

- .1 In accordance with Division 1.
- .2 Site Records:
- .1 Make available for reference purposes and inspection at all times. Provide sets of white prints as required for each phase of the work. Mark thereon all changes as work progresses and as changes occur. This shall include change orders, site instructions, and changes to existing mechanical systems, control systems and low voltage control wiring.
  - .2 Obtain AutoCAD drawing files from the consultant. The Contractor to update at his own expense the AutoCAD files to show the as-built conditions.
  - .3 On a regular basis, transfer information to the AutoCAD files, revising drawings to show all work as actually installed. These AutoCAD files will at their completion, become the as-built drawings for this project.
  - .4 Ensure that the modifications follow the same standard as the original file, that is, layer control, line weights, line types, etc.
  - .5 Make available for reference purposes and inspection at all times.
- .3 Record Drawings:
- .1 Prior to start of Testing, Adjusting and Balancing (TAB), finalize production of record drawings.
  - .2 Identify each drawing in lower right hand corner in letters at least 13 mm (1/2") high as follows: "RECORD DRAWINGS: THIS DRAWING HAS BEEN REVISED TO SHOW MECHANICAL SYSTEMS AS INSTALLED" (Signature of Contractor) (date).



- .3      Include on the Record Drawings the identification number off all terminal units and as installed location.
  - .4      Include on the Record Drawings as installed location of all temperature sensors and/or thermostats
  - .5      Submit to Consultant for approval and make corrections as directed.
  - .6      TAB to be performed using as-built drawings.
  - .7      Submit completed hard copy of as-built drawings with Operating and Maintenance Manuals.
  - .8      Submit computer disk with the AutoCAD files to the consultant at the time specified in Division 1.
- 
- .4      Where products are specified by manufacturer and/or model, update AutoCAD file to show installed manufacturer and model.
- 
- 2      Products      N/A**
  - 3      Execution      N/A**

**END OF SECTION**

## **1 General**

### **1.1 REFERENCE STANDARDS**

- .1 In accordance with Section 21 05 01 Common Work Results for Mechanical.

### **1.2 SUBMITTALS**

- .1 Start-up Report.
  - .1 Provide start-up reports as listed below.
  - .2 Reports to show model number, serial number, voltage and rated amperes.
  - .3 If during start up there is an operation concern, repeat start-up after operation concern has been corrected.
- .2 Section 21 05 02 Mechanical Submittals.
  - .1 Operation and Maintenance Manuals.
  - .2 Record drawings.
- .3 Section 21 05 03 Common Work Results for Mechanical Contract Closeout.
  - .1 Confirmation of Demonstration and Operating and Maintenance Instruction.
- .4 Section 23 21 14 Hydronic Specialties.
  - .1 Glycol percentage test report.
- .5 Section 24 05 93 Balancing (TAB) of Mechanical Systems.
  - .1 TAB Report.
- .6 Section 25 05 01 BAS: General Requirements.
  - .1 BAS start-up report including all field programmable software settings including demand expand setpoint and schedules.
  - .2 Letter confirming maintenance contract during warranty period.
  - .3 Printout of alarm limits.
  - .4 Printout of program.
  - .5 Copy of program on disks.
  - .6 Final Inspection certificate from Inspection Authority for Control Wiring Electrical Wiring Permit

### **1.3 DEMONSTRATION AND OPERATING AND MAINTENANCE INSTRUCTIONS**

- .1 Supply tools, equipment and personnel to demonstrate and instruct operating and maintenance personnel in operating, controlling, adjusting, trouble-shooting and servicing of all systems and equipment during regular work hours, prior to acceptance.
- .2 Use operation and maintenance manual, as-built drawings, audio visual aids, etc. as part of instruction materials.
- .3 Instruction duration time requirements at Substantial Performance as follows: 4 hours
- .4 Where deemed necessary, Owner may record these demonstrations on video tape for future reference.

## **2 Products N/A**

### **3        Execution**

#### **3.1      CLEANING**

- .1        Clean mechanical (building) systems in accordance with Division 1.
- .2        Clean all pipe systems strainers.
- .3        In preparation for final acceptance, clean and refurbish all equipment and leave in operating condition including replacement of all filters in all air and piping systems.

#### **3.2      VERIFICATION**

- .1        In context of this paragraph "verify" to include "demonstrate" to consultant.
- .2        Timing: commission only after start-up deficiencies rectified.
- .3        Controls: Refer to Section 25 05 01 BAS: General Requirements.
- .4        Verification reports:
  - .1        Record all results on approved report forms.
  - .2        Include signature of tester and supervisor.
- .5        Verification:
  - .1        Notify Consultant 24 hr before commencing tests.

**END OF SECTION**

## **1 General**

### **1.1 GENERAL**

- .1 The General Conditions of the contract as well as provisions of Division 1 and Section 21 05 01 Mechanical General Requirements, Section 21 05 02 Mechanical Submittals and Section 21 05 03 Mechanical Contract Closeout are part of and to be read in conjunction with this Section.

### **1.2 REFERENCE STANDARDS**

- .1 In accordance with Section 21 05 01 Mechanical General Requirements.

### **1.3 DEFINITIONS**

- .1 Firestopping: Material or combination of materials used to retain integrity of fire-rated construction by maintaining an effective barrier against the spread of flame, smoke, and hot gases through penetrations in fire rated wall and floor assemblies.

### **1.4 GENERAL DESCRIPTION OF THE WORK OF THIS SECTION**

- .1 Penetrations for the passage of duct, piping, and other mechanical equipment through fire-rated vertical barriers (walls and partitions), horizontal barriers (floor/ceiling assemblies), and vertical service shaft walls and partitions.

### **1.5 RELATED WORK OF OTHER SECTIONS**

- .1 Coordinate work of this section with work of other sections as required to properly execute the work and as necessary to maintain satisfactory progress of the work of other sections, including:
  - .1 Section 23 07 00 Mechanical Thermal Insulation.

### **1.6 QUALITY ASSURANCE**

- .1 A manufacturer's direct representative to be on-site during initial installation of firestop systems to train appropriate contractor personnel in proper selection and installation procedures. This will be done per manufacturer's written recommendations published in their literature and drawing details.
- .2 Firestop System installation must meet requirements of CAN4-S115-M or ULC S-115-M tested assemblies.
- .3 Firestop materials and methods: conform to applicable governing codes having local jurisdiction.
- .4 For those firestop applications that exist for which no ULC or cUL tested system is available through a manufacturer, a manufacturer's engineering judgment derived from similar ULC or cUL system designs or other tests will be submitted to local authorities having jurisdiction for their review and approval prior to installation. Engineer judgment drawings must follow requirements set forth by the International Firestop Council.

## **1.7 INSTALLER QUALIFICATIONS**

- .1 Engage an experienced Installer who is certified, licensed, or otherwise qualified by the firestopping manufacturer as having been provided the necessary training to install manufacturer's products per specified requirements.

## **1.8 DELIVERY, STORAGE AND HANDLING**

- .1 Deliver materials undamaged in manufacturer's clearly labeled, unopened containers, identified with brand, type, and ULC or cUL label where applicable.
- .2 Coordinate delivery of materials with scheduled installation date to allow minimum storage time at job-site.
- .3 Store materials under cover and protect from weather and damage in compliance with manufacturer's requirements.
- .4 Comply with recommended procedures, precautions or remedies described in material safety data sheets as applicable.
- .5 Do not use damaged or expired materials.

## **1.9 PROJECT CONDITIONS**

- .1 Do not use materials that contain flammable solvents.
- .2 Scheduling
  - .1 Schedule installation of Cast In Place firestop devices after completion of floor formwork, metal form deck, or composite deck but before placement of concrete.
  - .2 Schedule installation of other firestopping materials after completion of penetrating item installation but prior to covering or concealing of openings.
  - .3 Verify existing conditions and substrates before starting work. Correct unsatisfactory conditions before proceeding.
  - .4 Weather conditions: Install of firestop materials when temperatures are within the manufacturer's recommended limitations for installation printed on product label and product data sheet.
  - .5 During installation, provide masking and drop cloths to prevent firestopping materials from contaminating any adjacent surfaces.

## **2 Products**

### **2.1 FIRESTOPPING, GENERAL**

- .1 Use only firestop products that have been ULC or cUL tested for specific fire-rated construction conditions conforming to construction assembly type, penetrating item type, annular space requirements, and fire-rating involved for each separate instance.
- .2 Provide firestopping composed of components that are compatible with each other, the substrates forming openings and the items, if any, penetrating the firestopping under conditions of service and application, as demonstrated by the firestopping manufacturer based on testing and field experience.

- .3 Provide components for each firestopping system that are needed to install fill material. Use only components specified by the firestopping manufacturer and approved by the qualified testing agency for the designated fire-resistance-rated systems.

## 2.2 ACCEPTABLE MANUFACTURERS

- .1 Subject to compliance with through penetration firestop systems listed in U.L.C Fire Resistance Directory – Volume III or UL Products Certified for Canada (cUL) Directory, provide products of the following manufacturers as identified below:
  - .1 Hilti (Canada) Limited.
  - .2 Other manufacturers listed in the U.L.C Fire Resistance Directory – Volume III or UL Products Certified for Canada (cUL) Directory.

## 2.3 MATERIALS

- .1 Cast-in place firestop devices are installed prior to concrete placement for use with non-combustible and combustible plastic pipe (closed and open piping systems) penetrating concrete floors.
  - .1 Standard of Acceptance:
    - .1 Hilti CP 680 Cast-In Place Firestop Device
- .2 Sealants or caulking materials for use with non-combustible items including steel pipe, copper pipe and electrical metallic tubing (EMT).
  - .1 Standard of Acceptance:
    - .1 Hilti FS-ONE Intumescent Firestop Sealant, Hilti CP 604 Self Leveling Firestop Sealant, Hilti CP 620 Fire Foam
- .3 Sealants or caulking materials for use with sheet metal ducts.
  - .1 Standard of Acceptance:
    - .2 Hilti CP 601s Elastomeric Firestop Sealant, Hilti CP 606 Flexible Firestop Sealant, Hilti FS-ONE Intumescent Firestop Sealant, Hilti CP 604 Self Leveling Firestop Sealant.
- .4 Intumescent sealants or caulking materials for use with combustible items (penetrants consumed by high heat and flame) including insulated metal pipe, PVC jacketed or cable bundles and plastic pipe.
  - .1 Standard of Acceptance:
    - .1 Hilti FS-ONE Intumescent Firestop Sealant, Hilti CP 620 Fire Foam
- .5 Firestop collar or wrap devices attached to assembly around combustible plastic pipe (closed and open piping systems) tested to 50 Pa. differential.
  - .1 Standard of Acceptance:
    - .1 Hilti CP 642 Firestop Collar, Hilti CP 643 Firestop Collar, Hilti CP 645 Wrap Strips
- .6 Materials used for large size/complex penetrations made to accommodate multiple steel and copper pipes.
  - .1 Standard of Acceptance:
    - .1 Hilti FS 635 Trowel able Firestop Compound, Hilti FS 657 FIRE BLOCK, Hilti CP 620 Fire Foam

- .7 Non curing, re-penetrable materials used for large size/complex penetrations made to accommodate multiple steel and copper pipes.
- .1 Standard of Acceptance:
- .1 Hilti FS 657 FIRE BLOCK

<b>Fire Resistance Rating of Separation</b>	<b>Required ULC or cUL "F" Rating of Firestopping Assembly</b>
30 minutes	20 minutes
45 minutes	45 minutes
1 hour	45 minutes
1.5 hours	1 hour
2 hours	1.5 hours
3 hours	2 hours
4 hours	3 hours

- .8 For combustible pipe penetrations through a Fire Separation provide a firestop system with a "F" Rating as determined by ULC or cUL which is equal to the fire resistance rating of the construction being penetrated.
- .9 For penetrations through a Fire Wall or horizontal Fire Separation provide a firestop system with a "FT" Rating as determined by ULC or cUL which is equal to the fire resistance rating of the construction being penetrated.

### **3 Execution**

#### **3.1 PREPARATION**

- .1 Verification of Conditions: Examine areas and conditions under which work is to be performed and identify conditions detrimental to proper or timely completion.
- .2 Verify penetrations are properly sized and in suitable condition for application of materials.
- .3 Surfaces to which firestop materials will be applied shall be free of dirt, grease, oil, rust, laitance, release agents, water repellents, and any other substances that may affect proper adhesion.
- .4 Provide masking and temporary covering to prevent soiling of adjacent surfaces by firestopping materials.
- .5 Comply with manufacturer's recommendations for temperature and humidity conditions before, during and after installation of firestopping.
- .6 Do not proceed until unsatisfactory conditions have been corrected.

#### **3.2 COORDINATION**

- .1 Coordinate location and proper selection of cast-in-place Firestop Devices with trade responsible for the work. Ensure device is installed before placement of concrete.
- .2 Responsible trade to provide adequate spacing of field run pipes to allow for installation of cast-in-place firestop devices without interferences.

### **3.3 INSTALLATION**

- .1 Regulatory Requirements: Install firestop materials in accordance with ULC Fire Resistance Directory or UL Products Certified for Canada (cUL) Directory.
- .2 Seal all holes or voids made by penetrations to ensure an air and water resistant seal.
- .3 Consult with mechanical consultant, project manager and damper manufacturer prior to installation of ULC or cUL firestop systems that might hamper the performance of fire dampers as it pertains to duct work.
- .4 Protect materials from damage on surfaces subjected to traffic.

### **3.4 FIELD QUALITY CONTROL**

- .1 Examine sealed penetration areas to ensure proper installation before concealing or enclosing areas.
- .2 Keep areas of work accessible until inspection by applicable code authorities.
- .3 Perform under this section patching and repairing of firestopping caused by cutting or penetrating of existing firestop systems already installed by other trades.
- .4 Examine sealed penetration areas to ensure proper installation before concealing or enclosing areas.
- .5 Keep areas of work accessible until inspection by applicable code authorities.
- .6 Perform under this section patching and repairing of firestopping caused by cutting or penetrating of existing firestop systems already installed by other trades.
- .7 Install a warning card that is clearly visible adjacent to all openings. This card should contain the following information:
  - .1 Warning that the opening has being fire stop protected
  - .2 Indicate the fire stop system used (ULC or cUL)
  - .3 F rating or FT rating
  - .4 Fire stop product(s) used
  - .5 Person to contact and phone number in case of modification or new penetration of fire stop system

### **3.5 ADJUSTING AND CLEANING**

- .1 Remove equipment, materials and debris, leaving area in undamaged, clean condition.
- .2 Clean all surfaces adjacent to sealed holes and joints to be free of excess firestop materials and soiling as work progresses.

**END OF SECTION**



## 1 General

### 1.1 GENERAL

The General Conditions of the contract as well as provisions of Division 1 and Section 21 05 01 Mechanical General Requirements, Section 21 05 02 Mechanical Submittals and Section 21 05 03 Mechanical Contract Closeout are part of and to be read in conjunction with this Section.

### 1.2 REFERENCE STANDARDS

.1 In accordance with Section 21 05 01 Mechanical General Requirements.

## 2 Products

### 2.1 GENERAL

.1 Design point to be midpoint of scale or range.

.2 Dual Scale:

.1 Water and Glycol Thermometers: 0 to 115° C, 30° to 240° F.

.2 Pressure Gauges:

.1 Hydronic 0-400 kPa, 0 to 60 psi.

.3 Direct Reading Thermometers

.1 Industrial variable angle type 225 mm (9") scale length.

.2 Liquid filled or Solar powered

.3 Aluminum case

.4 Remote Reading Dial Thermometers

.1 100 mm (4 1/2") vapor activated dial type, accuracy within one scale division brass movement, stainless steel capillary, stainless steel spiral armor, stainless steel bulb and cast aluminum case for wall mounting.

.5 Thermometer Wells

.1 Copper pipe: use copper or bronze. For steel pipe use stainless steel.

.2 Steel Pipe:

.1 Open systems use stainless steel.

.2 Closed systems use brass.

.6 Pressure Gauges

.1 100 mm (4 1/2") dial type: liquid filled having 1% accuracy unless otherwise specified.

.2 Provide gauge cock. Ball valve in accordance with Section 23 05 23 Valves

.7 Acceptable Material

	Direct Reading Thermometers	Pressure Gauges
Terrice	BX 9140 or SX9140305	700 LFB
Weiss	A9VS9	NF4S-1
Winters	9IT with Aluminum case	100-4G
Weksler	EG5H-9 with Aluminum Case	EA14

### **3        Execution**

#### **3.1      GENERAL**

- .1        Provide thermometers and gauges so they can be easily read from floor or platform. If this cannot be accomplished, install remote reading thermometers and gauges.
- .2        Provide between equipment and first fitting or valve.
- .3        Increase pipe size at well to minimum NPS 2 to accommodate well.
- .4        Well to extend 6 mm to 12 mm into the pipe.

#### **3.2      DIRECT READING THERMOMETERS**

- .1        Provide in wells on all piping. Provide heat conductive material inside well.
- .2        Provide in the following locations:
  - .1        Heat exchangers inlets and outlets.
  - .2        In other locations as indicated.
- .3        Use extensions where thermometers are installed through insulation.

#### **3.3      PRESSURE GAUGES**

- .1        Provide in following locations:
  - .1        Suction and discharge of pumps and circulators over 373 kW (1/2 hp).
  - .2        In other locations as indicated.
- .2        Use extensions where pressure gauges are installed through insulation.

**END OF SECTION**

## 1 General

### 1.1 GENERAL

The General Conditions of the contract as well as provisions of Division 1 and Section 21 05 01 Mechanical General Requirements, Section 21 05 02 Mechanical Submittals and Section 21 05 03 Mechanical Contract Closeout are part of and to be read in conjunction with this Section.

### 1.2 REFERENCE STANDARDS

.1 In accordance with Section 21 05 01 Mechanical General Requirements.

### 1.3 MANUFACTURED ITEMS

.1 All valves of one type to be by one manufacturer.

### 1.4 LEAD FREE

.1 In accordance with NSF/ANSI 372 Drinking water system components – Lead Content or California Health and Safety Code (Section 116875; commonly known as AB1953) or Vermont Bill S.152

## 2 Products

### 2.1 VALVES NPS 2 AND UNDER

.1 Lead Free Ball Valves NPS 2 and under soldered and screwed:

.1 Application

.1 Section 23 21 13 Hydronic Systems

.2 Quarter-turn: 4130 kPa (600 psi) W.O.G., bronze, large port.

.2 Lead Free Swing Check Valves NPS 2 and under, soldered and screwed:

.1 Application

.1 Section 23 21 13 Hydronic Systems

.2 1380 kPa (200 psi) W.O.G., bronze body, bronze swing disc, screw in cap, regrindable seat.

.3 Acceptable material:

<b>NPS 2 and under</b>	<b>Lead Free Ball</b>	<b>Lead Free Check</b>
Milwaukee	UPBA150/ UPBA100	UP1509/UP509
Apollo	77CLF-100/77CLF-200	161S-LF/161T-LF
Nibco	S-685-80-LF /T -685-80-LF	S-413-Y-LF / T-413-Y-LF
Kitz	868/869	822T/823T
Watts	LFB6080/ LFB6081	LFCV/LFCVS

### 2.2 GROOVED END VALVES NPS 2 AND OVER FOR HYDRONIC

.1 Check Valves NPS 2 ½ to 4 for grooved end pipe:

.1 Class 125, 860 kPa (125 psi), ductile iron body, stainless steel discs, stainless steel spring, stainless steel shaft, EPDM seat.

- .2 Butterfly Valves NPS 2-1/2 and over grooved end body:
  - .1 Housing: Ductile iron conforming to ASTM A-536, grade 65-45-12 or ASTM A-395, grade 65-45-15
  - .2 Body: Carbon steel, electroplated
  - .3 Seat/Liner: Grade "E" EPDM. Temperature range -34° C to +110° C.
  - .4 ANSI/NSF 61 for cold +86°F/+30°C and hot 180°F/+82°C potable water service.
  - .5 Stem-Upper/Lower: 416 stainless steel
  - .6 Disc: Aluminum bronze
  - .7 Locking handle, gear operators NPS 6 and over.

- .3 Acceptable material:

<b>NPS 2-1/2 and up Grooved</b>	<b>Check</b>	<b>Butterfly</b>
Victaulic	Vic 716	Vic 300 MasterSeal
Anvil	7800	Series 7600
Nibco	-	GD-4765-3/5

### 2.3 DRAIN VALVES AND GAUGE COCKS

- .1 Lead Free Drain Valves
  - .1 Locate at low points of mains, branches and risers.
  - .2 At hydronic branch isolation valves, provide drain unless branch can be drained through a hydronic unit.
  - .3 Equipment drain valves line size.
  - .4 Minimum NPS 1/2 unless otherwise specified.
  - .5 Ball valve with hose end male thread and cap with chain.

- .2 Lead Free Gauge Cocks
  - .1 NPS 1/4 screwed.
    - .1 Application
      - .1 Pressure Gauge
      - .2 Air vents
      - .3 Where indicated
  - .2 Quarter-turn: 1725 kPa (250 psi) W.O.G., bronze.

- .3 Acceptable material:

	<b>Drain valves</b>	<b>Gauge Cocks</b>
Apollo	77CLF-100-HC/77CLF-200-HC	77CLF-100/77CLF-200
Kitz	868/869 w/cap and chain.	868/869
Nibco	S-685-80-LF-HC /T -685-80-LF-HC	S-685-80-LF /T -685-80-LF
Watts	LFB6080/ LFB6081 w/cap and chain	LFB6080/ LFB6081
Milwaukee	UPBA150/ UPBA100 w/cap and chain	UP1509/UP509

### 2.4 CIRCUIT BALANCING VALVE

- .1 Hydronic:
  - .1 Y style globe valve, designed to provide precise flow measurement and control, with valved ports for connected to differential pressure meter.
  - .2 Accuracy: Readout to be within plus or minus 2% of actual flow at design flow rate.
  - .3 Flow control: At least four (4) full turns of handwheel with digital handwheel and tamperproof concealed mechanical memory.
  - .4 Positive shut-off.
  - .5 Memory stop.

- .6 Connections:
  - .1 Screwed: NPS 1 to NPS 2.
  - .2 Flanged or Grooved: NPS 2 1/2 and over.
- .7 Standard of Acceptance:
  - .1 S. A. Armstrong CBV.
- .8 Acceptable Material:
  - .1 Hattersley 1710 and 737
  - .2 Tour and Anderson STA-D/F.
  - .3 Anvil Series GBV
  - .4 Oventrop Hydrocontrol 106 Series
  - .5 Victaulic 78 Series.

### **3 Execution**

#### **3.1 GENERAL**

- .1 Install valves with stems upright or horizontal unless approved otherwise.
- .2 Line size.

#### **3.2 CIRCUIT BALANCING VALVES**

- .1 Maintain Manufacturer's recommended minimum straight pipe diameters.

**END OF SECTION**

**1 General**

**1.1 GENERAL**

The General Conditions of the contract as well as provisions of Division 1 and Section 21 05 01 Mechanical General Requirements, Section 21 05 02 Mechanical Submittals and Section 21 05 03 Mechanical Contract Closeout are part of and to be read in conjunction with this Section.

**1.2 REFERENCE STANDARDS**

.1 In accordance with Section 21 05 01 Mechanical General Requirements.

**2 Products**

**2.1 GENERAL**

.1 Support from structural members. Where structural bearing does not exist or inserts are not in suitable locations, provide supplementary structural steel members.

**2.2 UPPER ATTACHMENTS**

- .1 Caddy clip for 6 mm (¼") rod Min 90 kg Static Load.
  - .1 Steel beam, channel, joist or angle.
  - .2 Application: Ductwork.
- .2 Steel washer plate with double locking nuts.
  - .1 Steel Joist.
  - .2 Application: Cold and hot, plumbing and hydronic piping, any size and ductwork.
- .3 Universal C-Clamp.
  - .1 Top of steel beam, top of channel, top of joist or angle.
  - .2 Application: Cold and hot, plumbing and hydronic piping, NPS 6 and under and ductwork.

.4 Acceptable material:

	<b>CCTF/Hunt</b>	<b>E. Myatt &amp; Co</b>	<b>Taylor Pipe Supports</b>	<b>Anvil</b>	<b>Carpenter and Paterson Pipe Hangers Ltd.</b>
Steel washer plate	560	545	80	60	260
Universal C-Clamp	56/56N/56NW		406/407	92/93/94	
C-Clamp	57	586	301	86	238

- .5 For pipes and ducts parallel to steel structure:
  - .1 Insert into floor slab above or
  - .2 Steel member from structural member to structural member.
  - .3 Double locking nuts.
- .6 Concrete:
  - .1 Inserts for cast-in-place concrete: galvanized steel wedge to MSS-SP-58, type 18. ULC listed for pipe NPS 3/4 through NPS 8.

### 2.3 MIDDLE ATTACHMENT (ROD)

- .1 Cadmium plated steel threaded rod:
  - .1 Acceptable Material:
    - .1 Carpenter & Paterson Pipe Hangers Ltd. Fig. 94.
    - .2 CCTF/Hunt Fig. 99P.
    - .3 Anvil Fig. 146.

### 2.4 PIPE ATTACHMENT

- .1 Adjustable clevis hanger: to MSS-SP69, type 1, ULC listed.
- .2 Long adjustable clevis hanger: to MSS-SP69, Type 1 ULC listed.
- .3 Copper plated or epoxy coated adjustable clevis hanger:
- .4 Black carbon steel riser clamp to MSS-SP69, Type 8, ULC listed.
  - .1 Application: Steel pipes and Cast iron pipe.
- .5 Copper plated carbon steel to MSS-SP69, Type 8, ULC listed:
  - .1 Application: Copper pipes.
- .6 Acceptable material:

	<b>CCTF/ Hunt</b>	<b>E. Myatt &amp; Co</b>	<b>Taylor Pipe Supports</b>	<b>Anvil</b>	<b>Carpenter and Paterson Pipe Hangers Ltd.</b>
Adjustable clevis hanger	32N	124	24Z	260	100
Long adjustable clevis hanger	32U	124L	24L	300	286
Copper plated or epoxy coated clevis hanger	30C/E	151CT or 56	52	CT65	100CT
Black carbon steel riser clamp	40	183	82	261	126
Copper plated riser clamp	42C	150CT	85	CT121	126CT

## 3 Execution

### 3.1 PIPE SUPPORT SPACING

- .1 Hydronic: Spacing and middle attachment (rod) diameter as specified in paragraphs below or as in table below, whichever is more stringent
  - .1 Plumbing piping: to National Plumbing Code of Canada.
  - .2 Authority having jurisdiction.
  - .3 Flexible joint roll groove pipe: in accordance with table below, but not less than one hanger at joints and not less than one hanger per pipe length over 1200 mm (4'0").
  - .4 Within 300 mm (12") of each elbow.
  - .5 Risers at each floor.
  - .6 Minimum hanger rod size as per full size manufacturer's recommendation and table below, whichever is greater.

<b>Pipe Size: NPS</b>	<b>Rod Diameter</b>	<b>Maximum Spacing Steel</b>	<b>Maximum Spacing Copper</b>
up to ¾	10 mm (3/8")	2100 mm (7'0")	1500 mm (5'0")
1 to 1-1/4	10 mm (3/8")	2100 mm (7'0")	1800 mm (6'0")
1-1/2	10 mm (3/8")	2750 mm (9'0")	2400 mm (8'0")
2	10 mm (3/8")	3000 mm (10'0")	2750 mm (9'0")
2-1/2	10 mm (3/8")	3350 mm (11'0")	3000 mm (9'10")
3	13 mm (1/2")	3650 mm (12'0")	3000 mm (9'10")
4	13 mm (1/2")	4250 mm (14'0")	3000 mm (9'10")

- .2 At Steel Joists
  - .1 Locate hangers at panel points of OWSJ for piping perpendicular to OWSJ.
  - .2 Locate steel support members at panel points of OWSJ for piping parallel to OWSJ.
  - .3 For parallel runs of piping NPS 2 ½ and over.
    - .1 Where perpendicular to OWSJ support on alternating OWSJ.

### 3.2 HYDRONIC PIPE

- .1 Upper Attachment as noted above.
- .2 Middle attachment as noted above.
- .3 Pipe Attachment Application
  - .1 Uninsulated steel pipe: All sizes.
    - .1 Adjustable clevis hanger.
  - .2 Hot insulated steel pipe: NPS 4 and under.
    - .1 Long adjustable clevis hanger.
  - .3 Copper pipe: All sizes
    - .1 Copper plated or epoxy coated adjustable clevis hanger.

### 3.3 DUCT HANGERS

- .1 In accordance with Section 24 31 13 Metal Ducts - Low Pressure to 500 Pa

### 3.4 MIDDLE ATTACHMENT (ROD)

- .1 Trim excess threaded rod off within 13 mm (1/2") of attachment nut.

### 3.5 HANGER INSTALLATION

- .1 Offset hanger so that rod is vertical in operating position.
- .2 Adjust hangers to equalize load.
- .3 Provide double nuts at middle attachment (rod) top and bottom.
- .4 Where building structural members or inserts are not suitably located provide supplementary steel channels or angles, support these channels and angles only from the top of structural members. Drill holes in the channels and angles for insertion of hanger rods. If the holes are cut out with a torch, provide a back-up steel plates with drilled holes for inserting hanger rods. Secure each hanger rod to the channels and angles using a steel back-up plate where applicable and steel washers and a lock-nut system. All channels, angles and hanger rod upper supports shall have a load capacity of five (5) times the load to be supported from them.

**END OF SECTION**



## **1 General**

### **1.1 GENERAL**

The General Conditions of the contract as well as provisions of Division 1 and Section 21 05 01 Mechanical General Requirements, Section 21 05 02 Mechanical Submittals and Section 21 05 03 Mechanical Contract Closeout are part of and to be read in conjunction with this Section.

### **1.2 REFERENCE STANDARDS**

.1 In accordance with Section 21 05 01 Mechanical General Requirements.

## **2 Products**

### **2.1 MANUFACTURERS NAMEPLATES**

- .1 Provide metal nameplate on each piece of equipment, mechanically fastened complete with raised or recessed letters. Locate nameplates so that they are easily read. Do not insulate or paint over nameplates.
- .2 Include registration plates (e.g. Pressure vessel, Underwriters' Laboratories and CSA Approval). Indicate size, equipment model, manufacturer's name, serial number, voltage, cycle, phase and power of motors.

### **2.2 SYSTEM NAMEPLATES**

- .1 Color:
  - .1 Hazardous: white letters, red background
  - .2 Elsewhere: black letters, white background (except where required otherwise by applicable codes).
- .2 Construction:
  - .1 2.4 mm (3/32") thick, laminated plastic or white anodized aluminum, matte finish, square corners, letters accurately aligned and machine engraved into core.
- .3 Equipment type, number and service or area or zone of building it serves to be identified.
- .4 Sizes:
  - .1 Conform to following table:

Size 1	10 mm x 50 mm (3/8" x 2")	1 line	5 mm (0.2") high letters
Size 2	13 mm x 75 mm (1/2" x 3")	1 line	6 mm (0.25") high letters
Size 6	25 mm x 100 mm (1" x 4")	1 line	13 mm (1/2") high letters
  - .2 Use average of 25 letters/numbers (maximum) per nameplate.
  - .3 Use Size 1.
    - .1 Control Components.
  - .4 Use Size 2.
    - .1 Inline circulators.
    - .2 Coils
    - .3 Motorized Dampers
    - .4 Mixing valves

- .5 Use Size 6.
  - .1 Control panels.
  - .2 Junction boxes.
  - .3 Relay panels.
- .5 Mechanically fasten nameplates.

## 2.3 PIPE IDENTIFICATION

- .1 General: Identify medium by lettered legend, classification by primary and secondary colors, direction of flow by arrows.
- .2 Primary color bands: 50 mm (2") wide.
- .3 Secondary color bands: 50 mm (2") wide, 75 mm (3") in from one end of primary color band.
- .4 Legend: block capitals to following table:

<b>Outside Diameter of Pipe or Insulation</b>	<b>Size of Letters</b>
Up to 1 1/4"	1/2"
1 1/2" to 2"	3/4"
2 1/2" to 6"	1 1/2"
Over 6"	2"
- .5 Arrows:
  - .1 Outside diameter of pipe/insulation 75 mm (3") and greater: 150 mm long x 50 mm high. (6" long x 2" high.)
  - .2 Outside diameter of pipe/insulation less than 75 mm (3"): 100 mm long x 50 high (4" long x 2" high.)
    - .1 Use double headed arrows where flow is reversible.
- .6 Material:
  - .1 Paint for Stencil: Low VOC and environmentally friendly
  - .2 Color bands:
    - .1 Plastic coated cloth material with protective overcoating and waterproof contact adhesive undercoating, suitable for 100% RH and continuous operating temperature of 150° C and intermittent temperature of 200° C. Apply to prepared surfaces. Wrap tape around pipe or pipe covering with ends overlapping one (1) pipe diameter. Cut band to length, don't tear off.
    - .2 Acceptable Manufacturer:
      - .1 WH Brady Inc.
      - .2 Seton Name Plate Corp.
- .7 Colors:
  - .1 Where not covered by table below, submit legend, primary and secondary classification colors to Consultant for approval.

- .8 Table: Pipe and valve identification.

<b>Pipe Marker Legend</b>	<b>Valve Legend</b>	<b>Tag Primary Color</b>	<b>Secondary Color</b>
Hot Water Heating Supply	HWS	Yellow	Black
Hot Water Heating Return	HWR	Yellow	Black
Glycol Heating Supply	GWS	Yellow	Black
Glycol Heating Return	GWR	Yellow	Black

- .9 Legend and arrows:

- .1 Black or white to contrast with primary color.

## 2.4 DUCTWORK

- .1 50 mm (2") high black stenciled letters and directional flow arrows 150 mm long x 50 mm high (6" long x 2" high).
- .2 Indicate "Supply", "Exhaust", with directional arrow and "Fan System No."

## 2.5 ELECTRICAL COMPONENTS SUPPLIED BY DIVISION 21 TO 25

- .1 Identify electrically fed equipment supplied by Division 25 as per Section 25 05 53 BAS Identification.

## 2.6 WARNING SIGNS

- .1 Equipment (e.g. motors, starters) under remote automatic control: provide orange colored signs warning of automatic starting under control of BAS.
- .2 Sign to read: "Caution: This equipment is under automatic remote control of BAS" or equivalent to Consultant's approval.

## 3 Execution

### 3.1 GENERAL

- .1 Provide ULC and CSA registration plates as required by Respective agency.

### 3.2 MANUFACTURERS NAMEPLATES

- .1 Locate nameplates so that they are easily read.
- .2 Do not insulate or paint over plates.

### 3.3 SYSTEM NAMEPLATES

- .1 In conspicuous location to facilitate easy reading from operating floor to properly identify equipment and/or system.
- .2 Provide stand-offs for nameplates on hot surfaces and insulated surfaces.

### **3.4      LOCATION OF PIPING AND DUCTWORK IDENTIFICATION**

- .1      On long straight runs in open areas in boiler rooms and equipment rooms, so that at least one is clearly visible from any one viewpoint in operating areas or walking isles and not at more than 50' intervals.
- .2      In addition to above, label Non Potable Cold Water not at not more than 7.5 meter (25') intervals.
- .3      Adjacent to all changes in direction.
- .4      At least once in each small room through which piping passes.
- .5      Both sides of visual obstruction or where run is difficult to follow.
- .6      On both sides of any separation such as walls, floors and partitions.
- .7      Where piping or ductwork is concealed in service chase, or other confined space, at entry and leaving points and adjacent to each access opening and not more than 15 meter (50') intervals.
- .8      At beginning and end points of each run and at each piece of equipment in run.
- .9      At point immediately upstream of major manually operated or automatically controlled valves or damper. Where this is not possible, place identification as close to valve or damper as possible, preferably on upstream side.
- .10     Legend to be easily and accurately readable from usual operating areas and all readily accessible points.
- .11     Plane of legend to be approximately at right angles to most convenient line of sight with consideration of operating positions, lighting conditions, reduced visibility of color or legends caused by dust and dirt and risk of physical damage.
- .12     Stencil over final finish only.
- .13     Beside each access door.

**END OF SECTION**

## **1 General**

### **1.1 GENERAL**

The General Conditions of the contract as well as provisions of Division 1 and Section 21 05 01 Mechanical General Requirements, Section 21 05 02 Mechanical Submittals and Section 21 05 03 Mechanical Contract Closeout are part of and to be read in conjunction with this Section.

### **1.2 REFERENCE STANDARDS**

- .1 In accordance with Section 21 05 01 Mechanical General Requirements.

### **1.3 DEFINITIONS**

- .1 Refer to Section 21 05 01 Common Work Results for Mechanical - General.
- .2 Legend
  - .1 ASJ: All Service Jacket
  - .2 SSL: Self-Sealing Lap
  - .3 FSK: Foil-Scrim-Kraft; jacketing
  - .4 PSK: Poly-Scrim-Kraft; jacketing
  - .5 PVC: Polyvinyl Chloride

### **1.4 ENVIRONMENTAL REQUIREMENTS**

- .1 Maintain ambient conditions required by manufacturers of tapes, adhesives, mastics, cements and insulation materials.
- .2 Follow manufacturer's recommended handling practices.

## **2 Products**

### **2.1 GENERAL**

- .1 Components of insulation system to have maximum flame spread rating of 25 and maximum smoke developed rating of 50 in accordance with CAN/ULC-S102.
- .2 Materials to be tested in accordance with ASTM C411.

### **2.2 PIPE INSULATION**

- .1 P-2 Formed Mineral Fiber with ASJ Vapour Barrier to 454° C
  - .1 Application for piping, valves and fittings on:
    - .1 Hydronic piping
    - .2 Where indicated.
  - .2 Material:
    - .1 CAN/CGSB 51.9 Mineral Fiber Thermal Insulation for Piping
    - .2 CGSB 51-GP-52 Vapour Barrier Jacket and Facing Material.
    - .3 Self-seal lap closure including ASJ butt strips.
  - .3 Thermal Conductivity "k" shall not exceed 0.034 W/m° C at 24° C mean temperature when tested in accordance with ASTM C335.

- .4 Thickness:
  - .1 Hydronic: 1"
- .5 All pipe insulation shall be by one manufacturer.
- .6 Copper tube size for copper pipe.

.2 Acceptable Material:

	<b>Owens-Corning</b>	<b>Manson Insulation Inc.</b>	<b>Knauf Fiber Glass</b>	<b>Johns Manville Insulations</b>
P-2	Fiberglas SSL-II	Alley K-APT	ASJ-SSL	Micro Lok AP-T

**2.3 DUCT INSULATION**

- .1 D-4 Mineral Fiber Rigid with ASJ Vapour Barrier to 4° to 120° C
  - .1 Application: on exposed cold or dual temperature ducting.
    - .1 Where indicated.
  - .2 Material:
    - .1 CAN/CGSB 51.11 Rigid Mineral Fiberboard.
    - .2 CGSB 51-GP-52 Vapour Barrier, Jacket and Facing Material.
  - .3 Thickness: One 25 mm (1") layer

.2 Acceptable Material:

	<b>Owens-Corning</b>	<b>Manson Insulation Inc.</b>	<b>Knauf Fiber Glass</b>	<b>Johns Manville Insulations</b>
D-4	Vapor Seal Duct Insulation AF-530	AK Board FSK	Insulation Board FSK	814 Spin Glass

**2.4 FASTENINGS**

- .1 Tape: self-adhesive, 100 mm (4") wide. ULC labeled for less than 25 flame spread and less than 50 smoke developed.
  - .1 Standard of Acceptance:
    - .1 S. Fattal Insultape.
- .2 Fire resistive lap seal adhesive: quick-setting for joints and lap sealing of vapour barriers.
  - .1 Standard of Acceptance:
    - .1 Monsey Bakor Inc. 230-39.
- .3 Fire resistive lagging adhesive: for cementing canvas lagging cloths to pipe insulation.
  - .1 Standard of Acceptance:
    - .1 Monsey Bakor Inc. 120-09.
- .4 Fire restrictive contact adhesive: quick setting.
  - .1 Standard of Acceptance:
    - .1 Monsey Bakor 230-38.
- .5 Pins:
  - .1 Weld pins 4 mm (5/32") diameter, with 32 mm (1 1/4") diameter head for installation through the insulation. Length to suit thickness of insulation.
  - .2 Standard of Acceptance:
    - .1 Duro Dyne, Clip-Pin
  - .3 Weld pins 4 mm (5/32") diameter, for installation prior to applying insulation. Length to suit thickness of insulation. Nylon retain clips 32 mm (1 1/4") round.

- .4 Standard of Acceptance:
  - .1 Duro Dyne Spotter Pins with Spotter-Clips.

## 2.5 JACKETS

- .1 Canvas.
  - .1 Plain weave, cotton fabric at 6.5 oz/yd<sup>2</sup> (220 g/m<sup>2</sup>).
  - .2 ULC label every 600 mm (2 ft.)
  - .3 Standard of Acceptance:
    - .1 S. Fattal Thermocanvas
- .2 Application:
  - .1 Exposed insulated piping
  - .2 Exposed insulated ductwork
- .3 PVC.
  - .1 CGSB 51-GP-53M PVC sheets.
  - .2 0.4 mm (0.015") thick minimum.
  - .3 Fitting covers, one piece, premoulded to match.
  - .4 Application on exposed insulated piping where noted below:
    - .1 Section 23 21 13 Hydronic Systems: Piping and Fittings for elbows and mechanical couplings only
  - .5 Standard of Acceptance:
    - .1 Proto.
    - .2 The Sure-Fit System.
    - .3 Zeston 2000 PVC.

## 2.6 FINISHING CEMENT TO 450° C

- .1 Thickness: 13mm (1/2").
- .2 Applications:
  - .1 Breechings.
  - .2 Heat Exchangers.
  - .3 Air Separators.
  - .4 Domestic hot water tanks.

## 2.7 REMOVABLE PRE-FABRICATED INSULATION PADS

- .1 Application:
  - .1 3 way control valves.
  - .2 Flanged equipment connections
  - .3 Valves and strainers over NPS 2.
- .2 To permit periodic removal and replacement without damage to adjacent insulation.

## 3 Execution

### 3.1 APPLICATION

- .1 Apply insulation after required tests have been completed and approved by Consultant.

- .2 Verify that all piping, equipment, and ductwork are tested and approved prior to insulation installation.
- .3 Verify that all surfaces are clean, dry and without foreign material before applying insulation materials.
- .4 Surfaces shall be clean and dry when installed and during application of insulation and finishes.
- .5 Apply insulation materials, accessories and finishes in accordance with manufacturer's recommendations and as specified herein.
- .6 All surface finishes shall be extended in such a manner as to protect all raw edges, ends and surfaces of insulation.
- .7 On piping with insulation and vapour barrier, maintain integrity of vapour barrier over full length of pipe without interruption at sleeves, fittings and supports.
- .8 On ductwork with insulation and vapour barrier, maintain integrity of vapour barrier over full length of duct or surface, without penetration for hangers, standing duct seams and without interruption at sleeves. Do not break continuity of insulation vapour barrier with hangers or rods. Insulate strap hangers 100 mm (4") beyond insulated duct.

### **3.2 PIPE INSULATION INSTALLATION**

- .1 Performed: sectional up to NPS 12, sectional or curved segmented above NPS 12.
- .2 Multi-layered: staggered butt joint construction.
- .3 Vertical pipe over NPS 3: insulation supports welded or bolted to pipe directly above lowest pipe fitting. Thereafter, locate on 15' centers.
- .4 Expansion joints in insulation: terminate single layer and each layer of multiple layers in straight cut at intervals recommended by manufacturer. Leave void of 25 mm (1") between terminations. Pack void tightly with P-3 flexible mineral insulation.
- .5 Seal and finish exposed ends and other terminations with insulating cement.
- .6 Insulation on roof drain body to be held in place with 100% coverage of adhesive. If the Roof Drain Body above the roof deck foam in place the cavity around the body.
- .7 Expansion joints in piping: provide for adequate movement of expansion joint without damage to insulator or finishes.
- .8 Fastenings
  - .1 Secure pipe insulation by tape at each end and center of each section, but not greater than 900 mm (36") on centers.

### **3.3 DUCT INSULATION INSTALLATION**

- .1 General:
  - .1 Adhere and seal vapour barrier using vapour seal adhesives.
  - .2 Stagger longitudinal and horizontal joints, on multilayered insulation.



- .2 Board Insulation fastenings:
  - .1 On rectangular ducts, use 50% coverage of insulating cement and weld pins at 1 pin per square foot, but not less than 2 rows per side and bottom.
  - .2 Secured with speed washers.
  - .3 All joints, breaks and punctures sealed with appropriate pressure-sensitive foil tape or glass fabric and vapor barrier mastic.
  - .4 Apply 20 gauge galvanized sheet metal corners to all duct work in mechanical rooms.
  - .5 Seal duct insulation vapor barrier to air handling unit.
  - .6 At exterior wall, Seal duct insulation vapor barrier to building envelope air barrier.
  
- .3 Flexible Blanket Insulation fastenings:
  - .1 Firmly butt all joints.
  - .2 The longitudinal seam of the vapor barrier must be overlapped a minimum of 50 mm (2").
  - .3 All penetrations and damage to the facing shall be repaired using pressure-sensitive foil tape, or mastic prior to system startup.
  - .4 Pressure-sensitive foil tapes shall be a minimum 75 mm (3") wide and shall be applied with moving pressure using a squeegee or other appropriate sealing tool.
  - .5 Secured to the bottom of rectangular ductwork over 600 mm (24") wide using mechanical fasteners on 450 mm (36") centers. Care should be exercised to avoid over-compression of the insulation during installation.
  
- .4 On exterior ductwork, provide weather barrier membrane.

### **3.4 EQUIPMENT INSULATION INSTALLATION**

- .1 Insulation supports where welding or bolting is permitted:
  - .1 Angle anchors: weld or bolt to equipment at lowest point of insulation. Thereafter, locate every 4500 mm (15') vertically.
  - .2 Welded steel clips: at 200 mm (8") maximum on centers, but not less than 2 rows per side.
  
- .2 Multi-layered: staggered butt joints and expansion joints in insulation, secured with wire or bands at 400 mm (16") on center intervals.
  
- .3 Expansion joints in insulation: leave 25 mm (1") space in each layer at 6000 mm (20') intervals. Pack space tightly with mineral fiber.
  
- .4 Insulation at bolts, studs, nuts, instrumentation: bevel to permit removal without damage to insulation or finish.
  
- .5 Fastenings: secure insulation with stainless steel wire at 900 mm (36") on center before application of finishing cement.
  
- .6 Vapour barriers: adhere and seal with vapour seal adhesive.
  
- .7 Finishes:
  - .1 Cement: apply over insulation in two 6 mm (1/4") thick layers, reinforced by 25 mm (1") mesh stainless steel wire netting.
  - .2 Canvas: sewn and pasted on to all insulation and over cement finishes. Seams inconspicuously placed.

- .3      Metal Jacket:
  - .1      Apply over insulation in lieu of cement finish where specified.
  - .2      Apply over insulation in lieu of canvas finish where specified.
  
- .8      Final surface: to be clean, smooth, ready for painting.

### **3.5      SPECIAL REQUIREMENTS**

- .1      Breechings: weld steel clips and/or angle anchors. Stretch 25 mm (1") mesh stainless steel wire over insulation, anchor to wire or bands. Finish with finishing cement jacket with canvas or aluminum.

**END OF SECTION**

## **1 General**

### **1.1 GENERAL**

The General Conditions of the contract as well as provisions of Division 1 and Section 21 05 01 Mechanical General Requirements, Section 21 05 02 Mechanical Submittals and Section 21 05 03 Mechanical Contract Closeout are part of and to be read in conjunction with this Section.

### **1.2 REFERENCE STANDARDS**

- .1 In accordance with Section 21 05 01 Mechanical General Requirements.

## **2 Products**

### **2.1 PIPE, FITTINGS, COUPLINGS AND JOINTS**

- .1 ASME/ANSI B16 series
- .2 Steel Pipe to ASTM A-53/A-135 Grade B.
  - .1 Application: Hydronic
  - .2 NPS 2 and Smaller Pipe Joints:
    - .1 Schedule 40: Screwed or Roll Grooved Couplings.
  - .3 NPS 2½ up to NPS 8 Pipe Joints:
    - .1 Schedule 40: Welded, Flanged, Roll Grooved Couplings.
  - .4 Screwed fittings with Teflon tape.
  - .5 Flanges: plain or raised face.
  - .6 Pipe fittings, screwed, flanged or welded: to ASME/ANSI B16 series
    - .1 Cast iron pipe flanges: Class 125.
    - .2 Malleable iron screwed fittings: Class 150.
    - .3 Steel pipe flanges and flanged fittings, Steel butt-welding fittings
    - .4 Unions, malleable iron
    - .5 Bolts and nuts: to ASME/ANSI B18.2.1 and ASME/ANSI B18.2.2.
- .3 Copper Tube: Type L hard drawn to ASTM B88M.
  - .1 Application: Hydronic
    - .1 Solder/brazing: lead free to ASTM B32.
    - .2 Brazed with Sil-Fos BCuP5: to ANSI/AWS A5.8.
    - .3 Cast bronze threaded fittings.
    - .4 Wrought copper and copper alloy solder joint pressure fittings.
    - .5 Cast copper alloy solder joint pressure fittings.
  - .2 Press Fitting:
    - .1 Application: Hydronic
    - .2 Copper and copper alloy press fittings conforming to material requirements of ASME B16.18 or ASME B16.22 and performance criteria of IAPMO PS 117.
    - .3 EPDM sealing elements for press fittings.
    - .4 Factory installed sealing elements.
    - .5 Press ends with leakage path feature that assures leakage of liquids from inside the system past the sealing element of an unpressed connection. The function of this feature is to provide the installer quick and easy identification of connections which have not been pressed prior to putting the system into operation.
    - .6 Acceptable Material: Viega Copper ProPress fittings.

## **2.2 ROLL GROOVED COUPLINGS AND FITTINGS**

- .1 Where rolled grooved couplings and fittings are used, they shall be of the same manufacturer.
- .2 Grooved products to have current CRN Numbers.
- .3 Ductile iron to ASTM A-536 or malleable iron to ASTM A-47 coupling housings painted with alkyd enamel.
- .4 Rigid Grooved type Couplings: Housings cast with offsetting angle-pattern bolt pads to provide rigidity and system support and hanging in accordance with ANSI B31.1 and B31.9.
- .5 Gaskets: Molded EPDM Compound to ASTM D-2000, -34° C to +110° C temperature range. Suitable all hydronic piping including hot water heating, glycol and chilled water supply and return piping.
- .6 Ductile iron to ASTM A-536 or malleable iron to ASTM A-47 fittings painted with alkyd enamel.
- .7 Coupling Bolts/Nuts: Heat treated carbon steel, track head to ASTM A-183 minimum tensile 110,000 psi.
- .8 Application
  - .1 Flexible couplings: At elbows except at pumps and coil connections.
  - .2 Rigid Couplings: Elsewhere.
- .9 Standard of Acceptance:
  - .1 Victaulic Co. of Canada Style 07 Zeroflex couplings with Grade E gasket, and grooved-end fittings.
  - .2 Victaulic Co. of Canada Style 107 Quick-Vic Installation ready rigid coupling, with EHP gasket for direct stab installation without field disassembly.
  - .3 Victaulic Co. of Canada Style 77 Flexible Couplings
  - .4 Victaulic Co. of Canada Style 117 Quick-Vic Installation ready flexible coupling, with EHP gasket for direct stab installation without field disassembly.
- .10 Acceptable Manufacturers: Anvil Gruvlok.

## **2.3 VALVES**

- .1 In accordance with Section 21 05 01 Common Work Results for Mechanical – General.

## **2.4 RELIEF VALVE PIPING AND DRAINS**

- .1 All sizes: Steel Pipe as noted above.

## **2.5 HANGERS SUPPORTS**

- .1 As per Section 23 05 29 Hangers and Supports.

## **2.6 INSULATION**

- .1 As per Section 23 07 00 Mechanical Thermal Insulation

## **3 Execution**

### **3.1 INSTALLATION**

- .1 Cut piping square, ream, ensure free of cuttings and foreign material.
- .2 Install pipes close to building structure to minimize furring, conserve headroom and space. Run piping parallel to walls. Group piping wherever possible.
- .3 Slope piping in direction of flow wherever possible. Slope for positive drainage and venting.
- .4 Use eccentric reducers for pipe size changes at wall fin connections to provide positive drainage or positive venting
- .5 Where pipe sizes differ from connection sizes of equipment, install reducing fittings close to the equipment. Reducing bushings are not acceptable.
- .6 Provide clearance for installation of insulation and access for maintenance of equipment, valves and fittings. Install piping, unions and flanges so that any fixed piping does not interfere with removal of coils, tubes or tube bundles.
- .7 Assemble piping using fittings manufactured to ANSI standards.
- .8 Saddle type branch fittings may be used on mains if branch line is half size or smaller than main. Hole saw or drill and ream main to maintain full inside diameter of branch line prior to welding saddle or installing mechanical T.
- .9 Minimum size NPS 3/4.
- .10 Forced water supply and return piping to be taken off main at 45° angle vertically from each main or branch. All runout made from main using four joint swing connection to permit expansion and avoid strain on equipment.
- .11 Ensure that proper clearance around equipment permits performance of service maintenance, that height clearance for piping is adequate. Check final location with Consultant if different from that shown prior to installation. Allow removal space for removal of all coils. Install piping, unions and flanges so that any fixed piping does not interfere with removal of coils, tubes or tube bundles.

### **3.2 RELIEF VALVE PIPING AND DRAINS**

- .1 Turn down at floor drain.
- .2 Cut end of discharge pipe at 45°.

### **3.3 ROLL GROOVED COUPLINGS AND FITTINGS**

- .1 Roll grooved product manufacturer to supply on site product installation training.

### **3.4 PRESS CONNECTION INSTALLATION**

- .1 In accordance with the manufacturer's installation instructions.
- .2 Fully inserted tubing into the fitting and the tubing marked at the shoulder of the fitting.
- .3 Check the fitting alignment against the mark on the tubing to assure the tubing is fully engaged (inserted) in the fitting.
- .4 Pressed the joints using the tool(s) approved by the manufacturer.

### **3.5 FLUSHING AND CLEANING**

- .1 Refer to Section 23 25 00 HVAC Water Treatment Systems.

### **3.6 TESTING**

- .1 Test system in accordance with Section 21 05 01 Common Work Results for Mechanical – General.
- .2 Repair any leaking joints, fittings or valves and retest.
- .3 For glycol systems, retest after filling with specified quality of glycol.

### **3.7 CONTROLS**

- .1 Install sensor wells and control valves supplied by Controls.

**END OF SECTION**

## **1 General**

### **1.1 GENERAL**

- .1 The General Conditions of the contract as well as provisions of Division 1 and Section 21 05 01 Common Work Results for Mechanical – General, Section 21 05 02 Common Work Results for Mechanical – Submittals and Section 21 05 03 Common Work Results for Mechanical - Contract Closeout, are part of and to be read in conjunction with this Section.

### **1.2 REFERENCE STANDARDS**

- .1 In accordance with Section 21 05 01 Common Work Results for Mechanical - General.

## **2 Products**

### **2.1 EXPANSION TANK**

- .1 Constructed in accordance with ASME requirements.
- .2 Capacity as indicated.
- .3 Suitable for 115° C operating temperature.
- .4 Working pressure: 860 kPa (125 psig).
- .5 Air precharged to 85 kPa (12 psig) (initial fill pressure of system) or as noted on drawings.
- .6 Basemount for vertical installation.
- .7 Bladder type
  - .1 Pressurized bladder type expansion tank.
  - .2 Replaceable Butyl Bladder.
  - .3 Standard of Acceptance:
    - .1 Bell & Gossett Series B
  - .4 Acceptable Manufacturer:
    - .1 Expanflex AL Series
    - .2 Taco Canada Ltd. CA Series
    - .3 S.A. Armstrong L Series.
    - .4 Amtrol L Series

### **2.2 AUTOMATIC AIR VENT**

- .1 Standard float vent with brass body and NPS 1/8 connection and rated at 690 kPa (100 psig) working pressure.
  - .1 Provide separate gauge cock. Refer to section 21 05 01 Common Work Results for Mechanical - General.
- .2 Industrial high capacity float vent with cast iron body and NPS 3/4 connection and rated at 690 kPa (100 psig) working pressure. Provide ball valve on inlet.
- .3 Float: solid material suitable for 115° C working temperature.

- .4 Standard of Acceptance
  - .1 Standard Vent: Amtrol 701.
  - .2 High Capacity Vent: Amtrol 720.
- .5 Acceptable Manufacturer:
  - .1 Bell & Gossett
  - .2 Taco Canada Ltd.

### **2.3 AIR SEPARATOR IN-LINE**

- .1 In-line air separator.
- .2 Strainer with valved bottom blow down connection.
- .3 Working pressure: 860 kPa (125 psig).
- .4 Size as indicated.
- .5 Acceptable Material:
  - .1 Bell & Gossett Rolairtrol
  - .2 S.A. Armstrong Vortex Air Separator
  - .3 Taco Canada Ltd. Air Separator

### **2.4 GLYCOL**

- .1 Pre-Mixed inhibited propylene glycol 40% by weight as indicated.
- .2 Acceptable Material:
  - .1 Dow Chemical Co.
  - .2 Specialty Chemical.
  - .3 Irving.
  - .4 Chemfax Chem Frost.

### **2.5 GLYCOL SYSTEM PRESSURE SAFETY RELIEF VALVE**

- .1 Valve: to ASME Section IV.
- .2 Body construction: brass.
- .3 Pressure setting: 210 kPa (30 psig).
- .4 Maximum operating differential pressure from open to close: 20 kPa (3 psig).
- .5 Standard of Acceptance:
  - .1 Watts 740 series
- .6 Acceptable Manufacturers:
  - .1 Bell & Gossett
  - .2 Armstrong
  - .3 Wilkins



## **2.6 GLYCOL FILL SYSTEM**

- .1 Minimum 180 liter (45 gallon) storage
- .2 Molded strong Polypropylene holding tank
- .3 Centrifugal pump: All bronze construction
- .4 Pump suction with inlet strainer
- .5 Isolation valve: Bronze construction
- .6 Check valve: Bronze construction
- .7 Low glycol cut-out float switch: 24 volt maximum (electrical safety)
- .8 Low glycol level cut-out switch
- .9 Low glycol level switch with separate indicator lamp to remind operator of top-up requirements
- .10 Pressure gauge
- .11 Integral pressure switch
- .12 Cord and plug
- .13 Voltage 120/1
- .14 Standard of Acceptance
  - .1 S. A. Armstrong Ltd. GLA
- .15 Acceptable Manufacturers
  - .1 Axiom Industries Ltd.
  - .2 Expanflex

## **3 Execution**

### **3.1 GENERAL**

- .1 Install according to piping layout. Pipe drains and blow off connections to nearest drain.
- .2 Maintain proper clearance around equipment to permit performance of service maintenance. Check final location with Consultant if different from that indicated prior to installation.
- .3 Should deviations beyond allowable clearances arise, request and follow Consultant's directive.
- .4 Check that all openings for appurtenances and equipment operating weight conform to shop drawings.
- .5 If accessories, ancillaries, are received knocked down, check assembly with Consultant.

### **3.2 AIR VENTS**

- .1 Install at high points of systems and where indicated.
- .2 Provide high capacity air vents at air separators. Pipe to floor drain.

### **3.3 AIR SEPARATORS**

- .1 Pipe blowdown to floor drain

### **3.4 EXPANSION TANKS**

- .1 Install lockshield type valve at inlet to tank.

### **3.5 TEST**

- .1 Test percentage of glycol in system and provide written confirmation of percentage.

**END OF SECTION**

## **1 General**

### **1.1 GENERAL**

The General Conditions of the contract as well as provisions of Division 1 and Section 21 05 01 Mechanical General Requirements, Section 21 05 02 Mechanical Submittals and Section 21 05 03 Mechanical Contract Closeout are part of and to be read in conjunction with this Section.

### **1.2 REFERENCE STANDARDS**

- .1 In accordance with Section 21 05 01 Mechanical General Requirements.

## **2 Products**

### **2.1 GENERAL**

- .1 Non overloading design.
- .2 Capacity: As per schedule on drawing.
- .3 Motor In accordance with Section 21 05 01 Common Work Results for Mechanical - General

### **2.2 WET ROTOR TYPE**

- .1 Maintenance-free, in-line, single stage, wet rotor type with the motor mounted directly to the pump volute.
- .2 Capable of operating continuously at temperatures from -10° C to 110° C for closed systems
- .3 Maximum working pressure shall be 1000 kPa.
- .4 Volute constructed of close-grained cast iron for closed systems
- .5 Impeller, impeller seal ring, rotor can, bearing plate, motor shaft, and rotor cladding constructed of stainless steel.
- .6 Impeller secured directly to the motor shaft by means of a stainless steel tapered split cone and locking nut.
- .7 Motor shaft with tungsten carbide bearing journals and supported by two aluminium oxide ceramic radial bearings.
- .8 Motor shaft with a stainless steel mounted carbon thrust bearing.
- .9 Motor:
  - .1 Capability to operate on each of three speeds selected using a built-in, three-speed switch
  - .2 Cooled and lubricated by the pumped fluid and require no scheduled maintenance.

- .10 Acceptable Material:
  - .1 Grunfos as per drawings.

### **3 Execution**

#### **3.1 INSTALLATION**

- .1 In line circulators: Install with flow vertically up or down and as indicated by flow arrows. Support at flanges or near unions on outlets of unit. Install with bearing lubrication points accessible. Check rotation.
- .2 Ensure that pump body does not support piping or equipment. Provide stanchions or hangers for this purpose. Refer to manufacturer's installation instructions for details.
- .3 Install volute venting pet cock in accessible location.

**END OF SECTION**

## **1 General**

### **1.1 GENERAL**

The General Conditions of the contract as well as provisions of Division 1 and Section 21 05 01 Mechanical General Requirements, Section 21 05 02 Mechanical Submittals and Section 21 05 03 Mechanical Contract Closeout are part of and to be read in conjunction with this Section.

### **1.2 REFERENCE STANDARDS**

.1 In accordance with Section 21 05 01 Mechanical General Requirements.

## **2 Products**

### **2.1 MANUFACTURER**

- .1 Equipment, chemicals and service by one manufacturer.
- .2 Acceptable Manufacturers:
  - .1 Dearborn
  - .2 Drew Chemicals
  - .3 T. Donovan & Son Ltd.
  - .4 State Industrial.

## **3 Execution**

### **3.1 INSTALLATION**

- .1 Install HVAC water treatment systems in accordance with ASME Boiler Code Section VII, and requirements and standards of authorities having jurisdiction.
- .2 Ensure adequate clearances to permit performance of servicing and maintenance of equipment.

### **3.2 POT FEEDERS**

- .1 Provide for each hydronic system.

### **3.3 CHEMICAL FEED PIPING**

- .1 Install crosses at all changes in direction. Install plugs in all unused connections.

### **3.4 FLUSHING OF MECHANICAL SYSTEM**

- .1 Flush after pressure test for a minimum of 4 hours.
- .2 During initial flushing, equipment, such as, plate heat exchangers, coils in air handling units and coils to be disconnected from the heating mains and the supply pipes and return pipes looped at the equipment. Final flushing to be through entire system. Provide temporary hose connectors to facilitate flushing.
- .3 Do not use system pumps. Provide a temporary flushing pump with a minimum capacity of 3 l/s (50 USgpm). Remove temporary flushing pump from site at end of project.

### **3.5      CLEANING OF MECHANICAL SYSTEM**

- .1      Provide copy of recommended cleaning procedures and chemicals for review by Consultant.
- .2      Thoroughly flush all mechanical systems and equipment with cleaning chemicals designed to remove deposition from construction such as pipe dope, oils, loose mill scale and other extraneous materials. Chemicals to inhibit corrosion of various systems materials and be safe to handle and use.
- .3      During circulation of cleaning solution, periodically examine and clean filters and screens and monitor changes in pressure drop across equipment.
- .4      Drain and flush systems until alkalinity of rinse water is equal to make-up water. Refill with clean water treated to prevent scale and corrosion during system operation.
- .5      Disposal of cleaning solutions to be approved by authority having jurisdiction.
- .6      Refill glycol systems with glycol of concentration as specified.
- .7      Following final filling of system, provide written recommendation for on going water treatment.

**END OF SECTION**

## **1        General**

### **1.1      GENERAL**

The General Conditions of the contract as well as provisions of Division 1 and Section 21 05 01 Mechanical General Requirements, Section 21 05 02 Mechanical Submittals and Section 21 05 03 Mechanical Contract Closeout are part of and to be read in conjunction with this Section.

### **1.2      REFERENCE STANDARDS**

- .1        In accordance with Section 21 05 01 Mechanical General Requirements.

### **1.3      GENERAL**

- .1        TAB means to test, adjust and balance to perform in accordance with requirements of Contract Documents and to do all other work as specified in this section.
- .2        Standard: TAB to be to most stringent of this section or TAB standards of AABC NEBB, SMACNA and ASHRAE.
- .3        TAB of all systems, equipment, components and controls specified Mechanical Contractor.

### **1.4      PURPOSE OF TAB**

- .1        Test to verify proper and safe operation, determine actual point of performance, evaluate qualitative and quantitative performance of equipment, systems and controls at design, average and low loads using actual or simulated loads
- .2        Adjust and regulate equipment and systems so as to meet specified performance requirements and to achieve specified interaction with all other related systems under all normal and emergency loads and operating conditions.
- .3        Balance systems and equipment to regulate flow rates to match load requirements over full operating ranges.

### **1.5      EXCEPTIONS**

- .1        TAB of systems and equipment regulated by codes, standards to be to satisfaction of authority having jurisdiction.

### **1.6      CO-ORDINATION**

- .1        Schedule time required for TAB (including repairs, re-testing) into project construction and completion schedule so as to ensure completion before acceptance of project.
- .2        Do TAB of each system independently and subsequently, where interlocked with other systems, in unison with those systems.

## **1.7 PRE-TAB REVIEW**

- .1 Review contract documents before project construction is started and confirm in writing to Consultant adequacy of provisions for TAB and all other aspects of design and installation pertinent to success of TAB.
- .2 Review specified standards and report to Consultant in writing all proposed procedures which vary from standard.
- .3 During construction, coordinate location and installation of all TAB devices, equipment, accessories, measurement ports and fittings.

## **1.8 START-UP**

- .1 Follow start-up procedures as recommended by equipment manufacturer unless specified otherwise.
- .2 Follow special start-up procedures specified elsewhere in Mechanical Contractor.

## **1.9 OPERATION OF SYSTEMS DURING TAB**

- .1 Operate systems for length of time required for TAB and as required by Consultant for verification of TAB reports.

## **1.10 START OF TAB**

- .1 Notify Consultant 7 days prior to start of TAB.
- .2 Start TAB only when building is essentially completed, including:
  - .1 Installation of ceilings, doors, windows, other construction affecting TAB.
  - .2 Application of weather-stripping, sealing, caulking.
  - .3 All pressure, leakage, other tests specified elsewhere Mechanical Contractor.
  - .4 All provisions for TAB installed and operational.
  - .5 Start-up, verification for proper, normal and safe operation of all mechanical and associated electrical and control systems affecting TAB including but not limited to:
    - .1 Proper thermal overload protection in place for electrical equipment.
    - .2 Air systems:
      - .1 Filters in place, clean.
      - .2 Duct systems clean.
      - .3 Ducts, air shafts, ceiling plenums are airtight to within specified tolerances.
      - .4 Correct fan rotation.
      - .5 Fire and volume control dampers installed and open.
      - .6 Coil fins combed, clean.
      - .7 Access doors, installed, closed.
      - .8 All outlets installed, volume control dampers open.
    - .3 Liquid systems:
      - .1 Flushed, filled, vented.
      - .2 Correct pump rotation.
      - .3 Strainers in place, baskets clean.
      - .4 Isolating and balancing valves installed, open.
      - .5 Calibrated balancing valves installed, at factory settings.
      - .6 Chemical treatment systems complete, operational.



### **1.11 APPLICATION TOLERANCES**

- .1 Do TAB to following tolerances of design values:
  - .1 HVAC systems: plus 10%, minus 5%.
  - .2 Hydronic systems: plus or minus 10%.

### **1.12 ACCURACY TOLERANCES**

- .1 Measured values to be accurate to within plus or minus 2% of actual values.

### **1.13 INSTRUMENTS**

- .1 Prior to TAB, submit to Consultant list of instruments to be used together with serial numbers.
- .2 Calibrate in accordance with requirements of most stringent of referenced standard for either applicable system or HVAC system.
- .3 Calibrate within 3 months of TAB. Provide certificate of calibration to Consultant.

### **1.14 TAB REPORT**

- .1 Format to be in accordance with reference standard.
- .2 TAB report to show all results in units specified on drawings and to include:
  - .1 System schematics.
- .3 Submit 3 copies of TAB Report to Consultant for verification and approval, in D-ring binders, complete with index tabs.

### **1.15 VERIFICATION**

- .1 All reported results subject to verification by Consultant.
- .2 Provide manpower and instrumentation to verify up to 30% of all reported results.
- .3 Number and location of verified results to be at discretion of Consultant.
- .4 Bear costs to repeat TAB as required to satisfaction of Consultant.

### **1.16 SETTINGS**

- .1 After TAB is completed to satisfaction of Consultant, replace drive guards, close all access doors, lock all devices in set positions, ensure sensors are at required settings.
- .2 Permanently mark all settings to allow restoration at any time during life of facility. Markings not to be eradicated or covered in any way.

### **1.17 COMPLETION OF TAB**

- .1 TAB to be considered complete only when final TAB Report received and approved by Consultant.

## 1.18 AIR SYSTEMS

- .1 TAB all systems, equipment, components, controls specified Mechanical Contractor.
- .2 Measurements: to include, but not limited to, following as appropriate for systems, equipment, components, controls:
  - .1 Air velocity.
  - .2 Static pressure.
  - .3 Velocity pressure.
  - .4 Air flow rate.
  - .5 Cross sectional area
  - .6 RPM: Fan and Motor
  - .7 Electrical power:
    - .1 Voltage
    - .2 Current draw
- .3 Locations of equipment measurements: To include, but not be limited to, following as appropriate:
  - .1 Inlet and Outlet of each:
    - .1 Fan
    - .2 Coil
    - .3 Filter
    - .4 Damper
    - .5 Other auxiliary equipment
- .4 Locations of systems measurements to include, but not be limited to, following as appropriate:
  - .1 Main ducts
  - .2 Main branch ducts
  - .3 Sub-branch ducts
  - .4 Each supply, exhaust and return air inlet and outlet
  - .5 Other auxiliary equipment
  - .6 All areas served by system.

## 1.19 HYDRONIC SYSTEMS

- .1 Definitions: for purposes of this section, to include low pressure hot water heating, chilled water, condenser water, glycol systems.
- .2 Measurements: to include, but not limited to, following as appropriate for systems, equipment, components, controls:
  - .1 Flow
  - .2 RPM
  - .3 Electrical Power:
    - .1 Voltage.
    - .2 Current draw.
- .3 Locations of equipment measurement: To include, but not be limited to, following as appropriate:
  - .1 Inlet and outlet of each:
    - .1 Heating exchanger (primary and secondary sides).
    - .2 Coil

- .3     Boiler
- .4     Pump
- .5     Other auxiliary equipment.

.4     Locations of systems measurements to include, but not be limited to, following as appropriate:

- .1     Heating water
- .2     Consider glycol systems as hydronic for purposes of this section.
- .3     Hydronic at circuit balancing valves

**2     Products (N/A)**

**3     Execution**

**3.1   TAB AGENCIES:**

- .1     Acceptable Agencies
  - .1     Atlantic Indoor Air Audit Co.
  - .2     Barrington Air Balance Service
  - .3     Griffin Air Balance Limited
  - .4     Scotia Air Balance 1996 Limited
  - .5     System Balance Limited

**END OF SECTION**

## **1 General**

### **1.1 GENERAL**

The General Conditions of the contract as well as provisions of Division 1 and Section 21 05 01 Mechanical General Requirements, Section 21 05 02 Mechanical Submittals and Section 21 05 03 Mechanical Contract Closeout are part of and to be read in conjunction with this Section.

### **1.2 REFERENCE STANDARDS**

.1 In accordance with Section 21 05 01 Mechanical General Requirements.

## **2 Products**

### **2.1 SEAL CLASSIFICATION**

.1 Ductwork classification as follows:

Maximum Pressure	SMACNA Seal Class
500 Pa	C

.2 Class C: transverse joints and connections made air tight with gaskets, sealant and tape or combination thereof. Longitudinal seams unsealed.

### **2.2 GALVANIZED STEEL**

.1 Lock forming quality: to ASTM A653, Z90 zinc coating.

.2 Thickness, fabrication and reinforcement: to ASHRAE and SMACNA or as indicated.

.3 Minimum 26 gauge

.4 Satin coat for all exposed ductwork outside mechanical rooms.

.5 Use oil free material and take all necessary measures to prevent contamination

.6 Joints: to ASHRAE and SMACNA and/or proprietary manufactured duct joint.

.1 Acceptable Material: for proprietary joints:

- .1 Ductmate Canada Ltd.
- .2 Exanno Nexus

### **2.3 RECTANGULAR DUCTWORK**

.1 Cross break ducts 450 mm (18") and larger for stiffening.

.2 Same gauge on all sides and based on the greater cross sectional dimension.

.3 Reinforce flat slip joints of ducts over 450 mm (18").

### **2.4 FITTINGS**

.1 Fabrication: to SMACNA.

- .2 Radiused elbows:
  - .1 Rectangular: Standard radius (Centerline radius 1.5 times width of duct) or short radius with single thickness turning vanes.
  - .2 Round: Smooth radius or 5 piece. Centerline radius is 1.5 times diameter.
- .3 Mitered elbows, rectangular:
  - .1 To and including 400 mm: Single thickness turning vanes.
  - .2 Over 400 mm: Double thickness turning vanes.
- .4 Sub branch duct with 45° entry and balancing damper on branch.
- .5 Transitions:
  - .1 Diverging: 20° maximum included angle.
  - .2 Converging: 30° maximum included angle.
- .6 Offsets: square elbows and/or full radiused elbows as indicated.
- .7 Obstruction deflectors: maintain full cross-sectional area. Maximum included angles as for transitions.

## **2.5 FIRESTOPPING**

- .1 Retaining angles all around duct, on both sides of fire separation.
- .2 Firestopping material and installation must not distort duct.

## **2.6 SEALANT**

- .1 Sealant: non-flammable, water base duct sealant.
- .2 Temperature range of -30° C to +93° C.
- .3 Flame spread rating of not more than 25.
- .4 Smoke developed classification of not more than 50.
- .5 Standard of Acceptance:
  - .1 Duro Dyne DSW

## **2.7 TAPE**

- .1 Poly-vinyl treated, open weave fiberglass tape.
- .2 50 mm (2") wide.
- .3 Standard of Acceptance:
  - .1 Duro Dyne FT-2.

## **2.8 HANGERS AND SUPPORTS**

- .1 Strap hangers: of same material as duct but next sheet metal thickness heavier than duct.

- .2 Maximum size rectangular and round duct supported by strap hanger: 500 mm (20").
- .3 Rectangular Hangers: angle iron with steel rods to ASHRAE and SMACNA following table:

<b>Duct Size</b>	<b>Angle Size</b>	<b>Rod Size</b>	<b>Spacing</b>
up to 30"	1" x 1" x 1/8"	1/4"	8'
31 to 36"	1 1/2" x 1 1/2" x 1/8"	1/4"	8'
37 to 60"	1 1/2" x 1 1/2" x 1/8"	3/8"	8'
61 to 84"	2" x 2" x 1/8"	3/8"	5'
85 to 96"	2" x 2" x 1/4"	3/8"	5'

- .4 Upper attachment:
  - .1 As per Section 23 05 29 Hangers and Supports
- .5 Middle attachment (Rod):
  - .1 As per Section 23 05 29 Hangers and Supports

### **3 Execution**

#### **3.1 GENERAL**

- .1 Install ducts in accordance with ASHRAE and SMACNA.
- .2 Support risers in accordance with ASHRAE and SMACNA.
- .3 Install breakaway joints in ductwork on each side of fire separation.
- .4 Seal between ducts and walls of mechanical room.
- .5 Where ducts are shown passing through rated fire separations provide fire dampers (in accordance with Section 24 33 16, Dampers Fire) and associated angle frames as per fire damper manufacturer's recommendations

#### **3.2 HANGERS**

- .1 Strap hangers: install in accordance with SMACNA.
  - .1 Minimum 25 mm (1") wide extending down 2 sides and 50 mm (2") under duct.
  - .2 Fasten to sides and bottom of duct.
- .2 Angle hangers: complete with locking nuts and washers.
  - .1 Rod attached to angle within 50 mm (2") of the duct sides.

#### **3.3 SEALING & TAPING**

- .1 Apply sealant to outside of joint to manufacturer's recommendations.
- .2 Bed Tape in sealant and recoat with minimum of 1 coat of seal and to manufacturer's recommendation.

**3.4      PROTECTION AND CLEANING**

- .1      Seal and protect open ends of ductwork continuously during construction.
- .2      Wash down inside of intake duct and plenum from louver to unit prior to starting units.

**END OF SECTION**

## **1 General**

### **1.1 GENERAL**

The General Conditions of the contract as well as provisions of Division 1 and Section 21 05 01 Mechanical General Requirements, Section 21 05 02 Mechanical Submittals and Section 21 05 03 Mechanical Contract Closeout are part of and to be read in conjunction with this Section.

### **1.2 REFERENCE STANDARDS**

.1 In accordance with Section 21 05 01 Mechanical General Requirements.

### **1.3 SHOP DRAWINGS**

.1 In accordance with Section 21 05 02 Mechanical Submittals.

## **2 Products**

### **2.1 AIR HANDLING UNITS GENERAL:**

- .1 Capacity: As per schedule on drawing.
- .2 Standard of Acceptance:
  - .1 Daikin-McQuay Vision as per drawings.
- .3 Acceptable Manufacturers:
  - .1 Engineered Air.
  - .2 Trane.
  - .3 York
- .4 Coil Section
  - .1 AHRI certify for hot water heating.
  - .2 Galvanized steel casing.
  - .3 5/8" OD copper tubes.
  - .4 Copper tube headers.
  - .5 Aluminum fin mechanically bonded to tube.
  - .6 Test to 250 psig.
  - .7 Same end connection.
  - .8 Vent & drain connections.
  - .9 40% Propylene Glycol unless otherwise noted.
  - .10 Fluid flow counter to airflow.

## **3 Execution**

### **3.1 INSTALLATION**

.1 Install units flat and level.

### **3.2 FANS**

.1 Provide fan sheaves required for final air balance.

**END OF SECTION**



## **1 General**

### **1.1 GENERAL**

The General Conditions of the contract as well as provisions of Division 1 and Section 21 05 01 Mechanical General Requirements, Section 21 05 02 Mechanical Submittals and Section 21 05 03 Mechanical Contract Closeout are part of and to be read in conjunction with this Section.

### **1.2 REFERENCE STANDARDS**

- .1 In accordance with Section 21 05 01 Mechanical General Requirements.

### **1.3 DEFINITIONS**

- .1 AEL: ratio between total test period less any system downtime accumulated within that period and test period.
- .2 Downtime: results whenever BAS is unable to fulfill all required functions due to malfunction of equipment defined under the responsibility of BAS contractor. Downtime is measured by duration, in time, between the time that the Contractor is notified of failure and the time system is restored to proper operating condition. Downtime not to include following:
  - .1 Outage of main power supply in excess of back-up power sources, provided that:
    - .1 Automatic initiation of back-up was accomplished.
    - .2 Automatic shut-down and re-start of components was as specified.
  - .2 Failure of communications link, provided that:
    - .1 Controller automatically and correctly operated in stand-alone mode.
    - .2 Failure was not due to failure of any specified BAS equipment.
    - .3 Functional failure resulting from individual sensor inputs or output devices, provided that:
      - .1 System recorded said fault.
      - .2 Equipment defaulted to fail-safe mode.
      - .3 AEL of total of all input sensors and output devices is at least 99 % during test period.

### **1.4 SYSTEM DESCRIPTION**

- .1 Work includes:
  - .1 Start-up testing and verification of all systems supplied under this section.
  - .2 Check out demonstration of proper operation of all components.
  - .3 On-site operational tests.
- .2 Following submission of report by contractor Consultant will review testing and verification as required.
- .3 Provide test equipment including two-way radios.
- .4 Independent testing laboratory to certify test equipment as accurate to within approved tolerances no later than 2 months prior to tests.
- .5 Inform and obtain approval from Consultant in writing at least 14 days prior to each test. Indicate:

- .1 Location and part of system to be tested.
- .2 Testing procedures, anticipated results.
- .3 Names of testing personnel.
  
- .6 Co-ordinate with other trades.
  
- .7 Correct deficiencies; re-test in presence of Consultant until satisfactory performance is obtained.
  
- .8 Acceptance of tests will not relieve Contractor from responsibility for ensuring that complete systems meet every requirement of Contract.
  
- .9 Load system with project software.

## 1.5 QUALITY ASSURANCE

- .1 Test after installation of each part of system and after completion of mechanical and electrical hook-ups, to verify correct installation and functioning.
  - .1 Test and calibrate field hardware including stand-alone capability of each controller.
  - .2 Verify each A-to-D convertor.
  - .3 Test and calibrate each AI using calibrated Binary instruments.
  - .4 Test each BI to ensure proper settings and switching contacts.
  - .5 Test each BO to ensure proper operation and lag time.
  - .6 Test each AO to ensure proper operation of controlled devices. Verify tight closure and signals.
  - .7 Test operating software.
  - .8 Test application software. Provide samples of logs and commands.
  - .9 Verify each CDL including energy optimization programs.
  - .10 Debug software.
  
- .2 Final Startup Testing
  - .1 Upon satisfactory completion of tests, perform point-by-point test of entire system under direction of Consultant.
  - .2 Provide:
    - .1 Two technical personnel capable of re-calibrating field hardware and modifying software.
    - .2 Detailed daily schedule showing items to be tested and personnel available.
    - .3 Key document for recording procedures to be listing of system database, including keyname, English description, point type and address, engineering units, low and high limits. Include space on listing for remarks and signatures of commissioning technician.
  
- .3 Final Operational Testing
  - .1 Purpose: to demonstrate that BAS functions in accordance with contract requirements.
    - .1 Prior to the commencement of 30 day test Contractor must demonstrate that operating parameters (setpoints, alarm limits and CDL's) have been implemented so as to ensure proper operation and operator notification in event of off-normal operation. Repetitive alarm conditions to be resolved so as to minimize reporting of nuisance conditions.

- .2 Test to last at least 30 consecutive 24 hour days.
- .3 Tests to include:
  - .1 Demonstration of correct operation of monitored and controlled points.
  - .2 Operation and capabilities of sequences, reports, special control algorithms, diagnostics, software.
- .4 System will be accepted when:
  - .1 BAS equipment operates to meet overall performance requirements. Downtime must not exceed allowable time calculated for this site.
  - .2 Requirements of Contract have been met.
- .5 In event of failure to attain specified AEL during test period, extend test period on day-to-day basis until specified AEL is attained for test period.
- .6 Correct defects when they occur and before resuming tests.

## 1.6 VERIFICATION

- .1 After installation of the system and completion of mechanical and electrical hook-up, perform point by point verification to confirm correct installation and functioning of equipment.
- .2 Submit a point by point Equipment Inspection and Verification Report to the consultant.
- .3 Following submission of the above point by point Equipment Inspection and Verification Report, notify the consultant in writing at least seven days prior to the Owner/Consultant point by point verification:
  - .1 Provide all necessary testing equipment, communication equipment and personnel.
  - .2 Perform Owner/Consultant verification in the presence of the Owner/Consultant.
  - .3 Demonstrate the proper operation of each component.
  - .4 Verify all Binary input alarm points by physically simulating an alarm condition.
  - .5 Calibrate all temperature, humidity, and pressure sensors using accurate electronic testing, equipment as a reference.
  - .6 Verify all control loops and programmed sequences of operation by simulating conditions for each mode of operation.
- .4 Correct any deficiencies and re-test in the presence of the consultant, until designated part of the system performs satisfactorily.

**2 Products N/A**

## 3 Execution

### 3.1 GENERAL

- .1 Cooperate with other section of Mechanical Contractor to start-up equipment and provide documentation included but not limited to the following:
  - .1 Testing, Adjusting & Balancing.

### 3.2 FIELD SERVICES

- .1 Prepare and start logic control system under provisions of this section.

- .2 Start-up, Check-out and Verification of systems: Allow sufficient time for start-up and verification prior to placing control systems in permanent operation. Provide the capability for off-site monitoring at control contractor's local or main office. At a minimum, off-site facility shall be capable of system diagnostics and software download.
- .3 Provide Owner's Representative with spare parts list. Identify equipment critical to maintaining the integrity of the operating system.

**END OF SECTION**

## **1        General**

### **1.1      GENERAL**

The General Conditions of the contract as well as provisions of Division 1 and Section 21 05 01 Mechanical General Requirements, Section 21 05 02 Mechanical Submittals and Section 21 05 03 Mechanical Contract Closeout are part of and to be read in conjunction with this Section.

### **1.2      REFERENCE STANDARDS**

- .1        In accordance with Section 21 05 01 Mechanical General Requirements.

### **1.3      RELATED SECTIONS**

- .1        Section 25 05 02 BAS: Submittals.
- .2        Section 25 01 11 BAS: Start-up Verification.
- .3        Section 25 30 01 BAS: Building Controllers.
- .4        Section 25 30 02 BAS: Field Control Devices.
- .5        Section 25 30 03 BAS Field Wire and Components Installation

### **1.4      BAS IDENTIFICATION**

- .1        Conform to requirements of Section 23 05 53 Mechanical Identification, supplemented and modified by requirements specified in this section.

### **1.5      REFERENCE STANDARDS**

- .1        The latest edition of the following standards and codes in effect and amended as of proposal date, and any applicable subsections thereof, shall govern design and selection of equipment and material supplied:
  - .1        American Society of Heating, Refrigerating and Air Conditioning Engineers (ASHRAE).
  - .2        ANSI/ASHRAE Standard 135, BACnet®.
  - .3        CSA C22.1 Canadian Electrical Code, Part 1 Safety Standard for Electrical Installations.
  - .4        Provincial and federal regulations and codes in effect as of contract date.
  - .5        Except as otherwise indicated the system supplier shall secure and pay for all permits, inspections, and certifications required for his work and arrange for necessary approvals by the governing authorities.

### **1.6      ACRONYMS, ABBREVIATIONS AND DEFINITIONS**

- .1        BACnet® Object List
  - .1        AI - Analog Input - Defined as any variable input (temperature), (Humidity), (position), etc.
  - .2        AO - Analog Output - Defined as any electrical variable output. 0–20mA, 4–20mA and 0–10VDC are the only acceptable analog outputs. The driver for analog outputs must come from both hardware and software resident in the controllers.

- .3 BI - Binary Input - Defined as any two-state input (alarm, status), etc.
- .4 BO - Binary Output - Defined as any two-state output (start/stop) (enable/disable), etc.
  
- .2 Acronyms used in Building Automation System (BAS).
  - .1 BAS - Building Automation System
  - .2 CDL - Control Description Logic
  - .3 COSV - Change of State or Value
  - .4 CPU - Central Processing Unit
  - .5 HVAC - Heating, Ventilation and Air Conditioning
  - .6 IDE - Interface Device Equipment
  - .7 I/O - Input/Output
  - .8 ISA - Industry Standard Architecture
  - .9 LAN - Local Area Network
  - .10 OS - Operating System
  - .11 O&M - Operation and Maintenance
  - .12 PCI - Peripheral Control Interface
  - .13 PCMCIA - Personal Computer Micro-Card Interface Adapter
  
- .3 Definitions:
  - .1 Point: a point may be logical or physical. Logical points are values calculated by system such as totals, counts, derived corrections i.e. as result of and/or statements in CDL's. Physical points are inputs or outputs which have hardware wired to controllers which are measuring or providing status conditions of contacts or relays providing interaction with related equipment (stop, start) or valve or damper actuators.

## 1.7 WORK INCLUDED

- .1 Control all mechanical equipment, including all unitary equipment such as heating pumps, fan-coils, etc. and all air handlers and any other listed equipment. Software shall include password protection, scheduling (including optimum start), alarming, logging of historical data, full graphics including animation, demand limiting, full suite of field engineering tools including graphical programming and applications.
- .2 Design and provide all equipment cabinets, panels, data communication network cables needed and all associated hardware. Provide all interconnecting cables between supplied cabinets, application controllers and input/output devices.
- .3 Work covered by sections referred to above consists of fully operational BAS, including, but not limited to, following:
  - .1 A fully integrated building automation system (BAS) incorporating direct digital control for energy management, equipment monitoring and control.
  - .2 Provide all communication media, connectors, repeaters, bridges, hubs, and routers necessary for the internetwork.
  - .3 Provide all interconnecting cables between all operator's terminals and peripheral devices (such as printers, etc.) supplied under this section.
  - .4 Peer-to-Peer Building Controllers.
  - .5 Control devices as listed in I/O Summaries and shown on the drawings.
  - .6 All control points viewable and controllable from the owner's BAS server
  - .7 Provide graphics for all systems on the owner's BAS server Sensor wells, flow switches and all control valves as indicated for installation by other sections of Mechanical Contractor.

- .8 Data communications equipment necessary to affect a BAS data transmission system.
  - .9 Field control devices.
  - .10 All software required to implement a complete and operational control system. Complete with full documentation for software and equipment.
  - .11 Complete operating and maintenance manuals and field training of operators, programmers and maintenance personnel.
  - .12 Acceptance tests, technical support during verification, full documentation.
  - .13 Control valve system.
  - .14 All necessary power required from local 120V/208V branch circuit panelboards for all controller equipment including the processor, applicable terminal devices and applicable field interface devices. Circuits to be for exclusive use of BAS equipment. Panel breakers to be identified on panel legends tagged and locks applied to breaker switches.
  - .15 All low voltage control transformers with suitable capacity to power all sensors, controller, etc. which require low voltage for operation.
  - .16 Except where otherwise noted, all wiring, conduit, boxes, miscellaneous material and labor associated with and required by the control system .
  - .17 Provide electrical permits as per this section.
  - .18 Data communication equipment necessary to affect a Building Automation System (BAS) data transmission system.
- .4 Related work performed by other Sections.
- .1 Hydronic Contractor to install wells, control valves supplied by this Section.
  - .2 This section to mount control damper actuators on the control dampers are supplied by Section 24 33 15 Dampers Operating
  - .3 This section to wire control damper actuators supplied by this section and supplied by Section 24 34 25 Package Exhausters.

## **1.8 COORDINATION**

- .1 Coordinate location of thermostats, temperature sensors, humidistats and other exposed control sensors with plans and room details before installation.
- .2 Coordinate equipment from other divisions including "Intrusion Detection," "Lighting Controls," "Motor Control Centers," "Panel boards," and "Fire Alarm" to achieve compatibility with equipment that interfaces with those systems.
- .3 Coordinate supply of conditioned electrical circuits for control units and operator workstation.
- .4 Coordinate with the Owner's IT department on locations for UNC's Ethernet communication cabling and TCP/IP address.

## **1.9 QUALITY ASSURANCE**

- .1 Responsible for inspection and Quality Assurance (QA) for all materials and workmanship furnished.
- .2 Component Testing: Maximum reliability shall be achieved through extensive use of high-quality, pre-tested components. Individually tested each and every controller, sensor and all other BAS components by the manufacturer prior to shipment.

- .3 Tools, Testing and Calibration Equipment: Provide all tools, testing, and calibration equipment necessary to ensure reliability and accuracy of the system.

#### **1.10 STANDARDS COMPLIANCE**

- .1 All equipment and material to be from manufacturer's regular production, CSA certified, manufactured to standard quoted plus additional specified requirements.
- .2 Where CSA certified equipment is not available submit such equipment to inspection authorities for special inspection and approval before delivery to site.
- .3 In lieu of such evidence, submit certificate from testing organization, approved by Consultant, certifying that item was tested in accordance with their test methods and that item conforms to their standard/code.
- .4 For materials whose compliance with organizational standards / codes / specifications is not regulated by an organization using its own listing or label as proof of compliance, furnish certificate stating that material complies with applicable referenced standard or specification.

#### **1.11 SYSTEM DESIGN RESPONSIBILITY**

- .1 Design and provide all conduit and wiring linking all elements of system, including future capability.
- .2 Supply sufficient programmable controllers of all types to meet project requirements. Quantity and points contents to be approved by Consultant prior to installation.
- .3 Location of controllers to be approved by Consultant prior to installation.

#### **1.12 WARRANTY**

- .1 Control system failures during warranty period shall be adjusted, repaired, or replaced at no additional cost or reduction in service to Owner. Respond during normal business hours within 24 hours of Owner's warranty service request 24 hours Monday through Friday and 48 hours on Saturday and Sunday.
- .2 The on-line support services via Internet shall allow the local BAS subcontractor to monitor and control the facility's building automation system. This remote connection to the facility shall be within 3 hours of the time that the problem is reported. This coverage shall be extended to include normal business hours, after business hours, weekends and holidays.
- .3 Provide updates to operator workstation or web server software, project-specific software, graphic software, database software, and firmware that resolve Contractor-identified software deficiencies at no charge during warranty period. If available, Owner can purchase in-warranty service agreement to receive upgrades for functional enhancements associated with above-mentioned items. Do not install updates or upgrades without Owner's written authorization.
- .4 Provide for 4 hours of customized programming after verification by the original programmer to ensure the intent of the original design is implemented. These hours can be used for program modifications, data acquisition analysis, meeting with owners or owner's representatives. Each hour of time shall be documented as to requested information and completed resolution.



### **1.13 OWNERSHIP OF PROPRIETARY MATERIAL**

- .1 Project-specific software and documentation shall become Owner's property. This includes, but is not limited to:
  - .1 Graphics
  - .2 Record drawings
  - .3 Database
  - .4 Application programming code
  - .5 Documentation

### **1.14 PERMITS, FEES AND INSPECTIONS**

- .1 Wiring: Refer to Section 25 30 03 BAS: Field Installation
- .2 Line Voltage Control Wiring
  - .1 Wiring shall be installed by an Electrician
  - .2 Electrical Wiring Permits
    - .1 Submit to Electrical Inspection Department and Supply Authority necessary number of Control Drawings and Control Specifications for examination and approval prior to commencement of work
    - .2 Pay associated fees.
    - .3 Furnish Certificates of Acceptance from Inspection Department and authorities having jurisdiction on completion of work.

## **2 Products**

### **2.1 GENERAL**

- .1 Control system installed to be "fail-safe".
- .2 Provide all required adapters between "metric" and "Imperial" components.
- .3 Capable of operating properly under environmental conditions of 0° C to 32° C and 10% to 95% non-condensing relative humidity.

### **2.2 PRODUCT**

- .1 Use new products the manufacturer is currently manufacturing and selling for use in new installations. Do not use this installation as a product test site unless explicitly approved in writing by Owner. Spare parts shall be available for at least seven years after completion of this contract.
- .2 Each major component of equipment shall have the manufacturer's name and address and the model and serial number on a nameplate.
- .3 Maintainability:
  - .1 The equipment designed in such a way that the time necessary for any repair or maintenance will be reduced to a minimum by using easily accessible modules, components and test jacks.
  - .2 Maintenance of any satellite panel or any peripheral device shall not affect the remainder of the system.
  - .3 Means must be provided for monitoring and locating component and system failures quickly and easily:

- .4 Integrate multiple building functions including equipment supervision and control, alarm management, energy management and historical data collection.
- .5 System architectural design shall eliminate dependence upon any single device for alarm reporting and control execution. Each BAS Controller shall operate independently by performing its own specified control, alarm management, operator I/O and data collection. The failure of any single component or network connection shall not interrupt the execution of control strategies at other operational devices.
- .6 BAS Controllers shall be able to access any data from, or send control commands and alarm reports directly to any other BAS Controller or combination of controllers on the network without dependence upon a central processing device. BAS Controllers shall also be able to send alarm reports to multiple operator workstations without dependence upon a central processing device.

### **2.3 ACCEPTABLE INSTALLER AND MATERIAL**

- .1 Acceptable Installer and Material:
  - .1 Extension of existing Controls & Equipment Limited with Delta Controls BTL Listed BACnet® Building Controllers (B-BC)

### **2.4 LOCKABLE CONTROL ENCLOSURES**

- .1 Enclosures to bear the appropriate CSA designation i.e. CSA Enclosure 1 - General Purpose, CSA Enclosure 3 - Weatherproof.
- .2 To have hinged doors equipped with standard keyed-alike cabinet locks, keyed to same key.
- .3 Either free-standing or wall mounted enameled steel cabinets with hinged and key-locked front door.
- .4 Modular multiple panels as required to handle requirements with additional space to accommodate future capacity without adding additional cabinets.
- .5 Cabinets: 12 gauge furniture steel (12 gauge) with baked enamel finish on exterior and rust inhibitive paint on interior, for surface mounting, with hinged door, latch lock, 2 keys, complete with perforated metal mounting backboard.
- .6 Factory installed bonding and neutral termination strips.
- .7 Provide for conduit entrance from top, bottom or sides of panel.
- .8 Cabinets to provide protection from water dripping from above, while allowing sufficient airflow to prevent internal overheating.

## **3 Execution**

### **3.1 EXAMINATION**

- .1 Prior to starting work, carefully inspect installed work of other trades and verify that such work is complete to the point where work of this Section may properly commence.

- .2 Notify the owners' representative in writing of conditions detrimental to the proper and timely completion of the work.
- .3 Do not begin work until all unsatisfactory conditions are resolved.

### **3.2 INSTALLATION**

- .1 Install BAS in accordance with manufacturer's instructions.
- .2 Provide all miscellaneous devices, hardware, software, interconnections installation and programming required to ensure a complete operating system in accordance with the sequences of operation and point schedules.

### **3.3 ELECTRICAL ENCLOSURES**

- .1 House all electrical equipment associated with the control system in separate dedicated enclosures provided by this section.
- .2 House all controllers associated with the control system in lockable enclosures provided by this section.
- .3 Colour code enclosure as per Section 23 05 53 Mechanical Identification
- .4 Provide size 2 nameplate identification.
- .5 Under no circumstances utilize equipment enclosures such as junction boxes, etc., supplied by Electrical Contractor or other sections of Mechanical Contractor to house control system components. Refer to Section 25 30 02 BAS: Field Control Devices for current sensors and associated relay inside starters and MCC's
- .6 Maintain minimum 1 meter clear in front of enclosure.
- .7 Top of lockable enclosure to be 1980 mm AFF.
- .8 Wiring within panels: locate in trays or individually clipped to back of panel.

### **3.4 BAS OBJECT TYPE SUMMARY**

- .1 Provide all database generation.
- .2 Displays: System displays shall show all analog and binary object types within the system. They shall be logically laid out for easy use by the owner. Provide outside air temperature indication on all system displays associated
- .3 Run Time Totalization: At a minimum, run time totalization shall be incorporated for each monitored supply fan, return fan, exhaust fan and hot water pumps. Warning limits for each point shall be entered for alarm and or maintenance purposes.
- .4 Trend log: All binary and analog object types (including zones) shall have the capability to be automatically trended.

- .5      Alarm: All analog inputs (High/Low Limits) and selected binary input alarm points shall be prioritized and routed (locally or remotely) with alarm message per owner's requirements.
  
- .6      Database Save: Provide back-up database for all stand-alone application controllers on disk.

### **APPENDIX “B” BAS Device and Building addressing**

#### **B.1      Match existing Building addressing**

**END OF SECTION**

## **1 General**

### **1.1 GENERAL**

The General Conditions of the contract as well as provisions of Division 1 and Section 21 05 01 Mechanical General Requirements, Section 21 05 02 Mechanical Submittals and Section 21 05 03 Mechanical Contract Closeout are part of and to be read in conjunction with this Section.

### **1.2 REFERENCE STANDARDS**

- .1 In accordance with Section 21 05 01 Mechanical General Requirements.

### **1.3 SUBMITTALS**

- .1 In accordance with Division 1 and Section 21 05 02 Common Work Results for Mechanical - Submittals, supplemented and modified by requirements specified in this section.
- .2 Project records and Operating and Maintenance (O & M) manuals specified in this section are to be integrated with those specified in Section 21 05 02 Common Work Results for Mechanical - Submittals.

### **1.4 SHOP DRAWING SUBMITTALS**

- .1 Completely indexed and coordinated package to assure compliance with contract requirements and arranged in same sequence as specification and cross-referenced to specification section and paragraph number.
  - .1 Product data sheets: Provide index and number pages
- .2 Submit control diagrams,
  - .1 Sequences of operation for each system,
  - .2 All input/output object listings and an alarm point summary listing.
  - .3 Complete valve schedule listing including following information: designation, service, manufacturer, model, point ID, design flow rate, design pressure drop, required Cv, Valve size, actual Cv, spring range, pilot range, required torque, actual torque.
  - .4 Complete damper motor schedule listing including following information: designation, service, manufacturer, model, point ID, design flow rate, required torque, actual torque.
  - .5 Specification sheets for each item to include manufacturer's descriptive literature, specification, drawings, diagrams, performance and characteristic curves, catalogue cuts, manufacturer's name, trade name, catalogue or model number, nameplate data, size, layout, dimensions, capacity, other data to establish compliance.
  - .6 Sketch of site-specific system architecture.
  - .7 Specification sheets for each item including memory provided, programming language, speed, type of data transmission.
  - .8 Electrical interface drawings specific to project showing Electrical Contract starters where applicable for safeties and automatic motor control using industry standard symbols.
  - .9 Spare point capacity of each controller by number and type.
  - .10 Controller locations.

- .11 Interface wiring diagrams showing termination connections and signal levels for equipment to be supplied by others.
  - .12 Sensing element type and location.
  - .13 Transmitter type and range.
- .3 Provide 1 non-fading "As-Built" copy copies showing control and/or adjustment procedures. Enclose in aluminum frame with non-glare glass cover or seal in plastic laminate in rigid metal bound loose leaf.

## **1.5 BAS DEMONSTRATION, OPERATING AND MAINTENANCE INSTRUCTION**

- .1 Provide the services of competent instructors who will give full instruction to designated personnel in the adjustment, operation and maintenance, including pertinent safety requirements of the equipment and system specified.
- .2 Provide a training manual for each trainee. The Manual shall describe in detail the data included in each training program. Provide all equipment and material required for classroom training.
- .3 Provide equipment, visual and audio aids, and materials for classroom training.

## **1.6 RECORD DRAWINGS**

- .1 Conform to requirements of Division 1 and Section 21 05 01 Common Work Results for Mechanical - General, supplemented and modified by requirements specified in this section.
- .2 Final Control Diagrams
  - .1 Changes to contract documents as well as addenda and contract extras.
  - .2 Changes to interface wiring.
  - .3 Major routing of conduit and control air lines.
  - .4 Signal levels, setpoints, reset curves, schedules.
- .3 Bind with specified Operating and Maintenance Manuals.
- .4 Provide listing of alarm messages.
- .5 Provide 1 non-fading "Record" copy copies showing control and/or adjustment procedures. Enclose in aluminum frame with non-glare glass cover or seal in plastic laminate in rigid metal bound loose leaf.
- .6 Include complete coverage in concise language readily understood by operating personnel using common terminology of functional and operational requirements of system. Do not presume knowledge of computers, electronics or in-depth control theory.
- .7 Functional description to include:
  - .1 Functional description of theory of operation.
  - .2 Design philosophy.
  - .3 Specific functions of design philosophy and system.
  - .4 Full details of data communications, including data types and formats, data processing and disposition data link components, interfaces and operator tests or self-test of data link integrity.

- .5 Explicit description of hardware and software functions, interfaces, requirements for components in functions and operating modes.
- .6 Description of person-machine interactions required to supplement system description, known or established constraints on system operation, operating procedures currently implemented or planned for implementation in automatic mode.
- .8 System operation to include:
  - .1 Complete step-by-step procedures for operation of system including required actions at each OWS.
  - .2 Operation of computer peripherals, input and output formats.
  - .3 Emergency, alarm and failure recovery.
  - .4 Step-by-step instructions for start-up, back-up equipment operation, execution of all systems functions and operating modes, including key strokes for each command so that operator need only refer to these pages for keystroke entries required to call up display or to input command.
- .9 Software to include:
  - .1 Documentation of theory, design, interface requirements, functions, including test and verification procedures.
  - .2 Detailed descriptions of program requirements and capabilities.
  - .3 Data necessary to permit modification, relocation, reprogramming and to permit new and existing software modules to respond to changing system functional requirements without disrupting normal operation.
  - .4 Software modules, fully annotated source code listings, error free object code files ready for loading via peripheral device
  - .5 Complete program cross reference plus any linking requirements, data exchange requirements, necessary subroutine lists, data file requirements, other information necessary for proper loading, integration, interfacing, program execution.
  - .6 Software for each Controller and single section referencing all Controller common parameters and functions.
- .10 Maintenance: document maintenance procedures including inspection, periodic preventive maintenance, fault diagnosis, repair or replacement of defective components, including calibration, maintenance, repair of sensors, transmitters, transducers, Controller interface firmware's, plus diagnostics and repair/replacement of system hardware.
- .11 Test procedures and reports: record implementation, description of test procedures. Provide for measurement or observation of results.
- .12 System configuration document:
  - .1 Basic system design and configuration.
  - .2 Provisions and procedures for planning, implementing, recording hardware and software modifications required during installation, test and operating lifetime of system.
  - .3 Information to ensure co-ordination of hardware and software changes, data link or message format/content changes, sensor or control changes in event that system modifications are required.
  - .4 Full documentation of new system configurations.
- .13 PROM programmer and test equipment manual: include full documentation on PROM's including as minimum PROM locations in system, stock number, Programmer/PROM unique considerations.

- .14 Programmer control panel documentation: provide where panels are independently interfaced with BAS, including interfacing schematics, signal identification, timing diagrams, fully commented source listing of applicable driver/handler.

**2 Products N/A**

**3 Execution**

**3.1 MONITORING OF BAS TRAINING**

- .1 Consultant will monitor training program and retains right to modify schedule and content.

**END OF SECTION**



## 1 General

### 1.1 GENERAL

The General Conditions of the contract as well as provisions of Division 1 and Section 21 05 01 Mechanical General Requirements, Section 21 05 02 Mechanical Submittals and Section 21 05 03 Mechanical Contract Closeout are part of and to be read in conjunction with this Section.

### 1.2 REFERENCE STANDARDS

- .1 In accordance with Section 21 05 01 Mechanical General Requirements.

### 1.3 IDENTIFICATION REQUIREMENTS

- .1 Identify all electrical equipment by the use of Lamecoid plates.
- .2 All enclosures receiving connections to the building power distribution system shall have their panel and circuit number identified by the use of Lamecoid plates. This includes equipment supplied by this contractor.
- .3 Colour code all electrical junction, pull boxes and splitters inside and out with appropriate colored paint. **Apply all paint prior to installation and not with-in the confines of the building.**
- .4 Colour code all conduit couplings with appropriate colored paint. **Apply all paint prior to installation and not with-in the confines of the building.**
- .5 All junction boxes shall have the panel and circuit numbers contained with-in, identified on the cover plate.
- .6 Identify all wiring through the use of self-laminating labels.
- .7 Identify all control panels through the use of Lamecoid plates.
- .8 Identify all relay panels through the use of Lamecoid plates.
- .9 Identify all electrical devices (receptacles, relay panels, power supplies, etc.) and electrical equipment and electrical equipment in concealed ceiling spaces with two (2) Lamecoid plates, one on the device, junction box and equipment and one on the ceiling below.

## 2 Products

### 2.1 IDENTIFICATION NAMEPLATES

- .1 Lamecoid identification plates.
  - .1 Lamecoid 3 mm thick plastic engraving sheet for all BAS systems, complete with **rounded upper corners**. Lamecoid characteristics are to be as follows, unless noted otherwise:
    - .1 Electrical equipment enclosures to have black face with white core Lamecoid plates.
    - .2 All ceiling mounted plates to have white face with black core.

## **.2 NAMEPLATE SIZES**

Size 1	10 mm x 50 mm (3/8" x 2")	1 line	5 mm (0.2") high letters
Size 2	13 mm x 75 mm (1/2" x 3")	1 line	6 mm (0.25") high letters
Size 3	16 mm x 75 mm (3/4" x 3")	2 line	5 mm (0.2") high letters
Size 4	19 mm x 90 mm (3/4" x 3.5")	1 line	10 mm (3/8") high letters
Size 5	38 mm x 90 mm (1.5" x 3.5")	2 line	13 mm (1/2") high letters
Size 6	25 mm x 100 mm (1" x 4")	1 line	13 mm (1/2") high letters
Size 7	25 mm x 100 mm (1" x 4")	2 line	6 mm (1/4") high letters
Size 8	50 mm x 150 mm (2" x 6")	2 line	13 mm (1/2") high letters
Size 9	75 mm x 150 mm (3" x 6")	3 line	13 mm (1/2") high letters

.3 Identification to be in English.

## **2.2 COLOUR CODING OF ELECTRICAL BOXES**

.1 Colour coding of splitters, junction boxes, pull boxes and outlet boxes as follow:

System	Primary Colour	Secondary Colour
0 to 50 volts	Violet	-
51 volts to 240 volts	YELLOW	-
Above 240 volts	ORANGE	-
Ground or Bond	GREEN	-
Building Automation System	RED	WHITE

.2 All various systems junction and/or pull boxes etc., where located above grid system, shall have location identified on underside or room side of T-bar spline, with (19 mm) or (6 mm on 19 mm) self-adhering colour coded circular shaped discs, affixed directly to spline in close proximity to where concealed box is located. The same type of discs to be installed on ceiling or wall access cover plates.

.1 6 mm (1/4") discs are all white in colour.

.2 19 mm (3/4") discs are colored as indicated.

.3 6 mm (1/4") to be affixed to center or middle of 19 mm (3/4") discs as system colours dictates.

.3 Refer to Part 3 of this section with regard to identification painting.

## **2.3 WIRING IDENTIFICATION**

.1 Wiring Labels:

.1 Write on self-laminating labels.

.2 Panduit No's PLD-1, PLD-2.

## **2.4 NAMEPLATES FOR BAS FIELD DEVICES**

.1 As a minimum, control device identification shall correspond to descriptors provided in the reviewed shop drawings with respect to panel designation or BAS point name.

.2 Identify intermediate and end control devices including sensors, controllers, monitoring devices etc. as follows:

.1 Laminated plastic plates nameplates attached by chain or heavy duty plastic tie wraps.

.2 Plastic encased cards

.1 Sizes: 50 x 100 mm minimum.

- .2 Lettering: 6 mm minimum high produced from laser printer in black.
- .3 Data to include: point name, schematic designation number, model, capillary length, size, range, set point, other pertinent data, function, fail-safe position.
- .4 Attached by chain or heavy duty plastic tie wraps.
- .3 Field Device Tagging:
  - .1 90 x 24 x 4 mm white styrene plastic with 5mm diameter hole for chain or tie wrap mounting.
  - .2 Lettering:
    - .1 20 pt bold for point name
    - .2 12 pt reg for point descriptor
    - .3 10 pt reg for point address
    - .4 Miscellaneous text 8 pt regular
  - .4 Full stick-on labels attached to plastic backing. Labels generated by Excel spreadsheet of point database then imported to any common label making machine (i.e. Brother P-touch). Labels and text can be any color.
  - .5 90 x 24 x 4 mm clear plastic with 5mm diameter hole for chain or tie wrap mounting.

## 2.5 WARNING SIGNS

- .1 Equipment (e.g. motors, starters) under remote automatic control: provide orange colored signs warning of automatic starting under control of BAS.
- .2 Sign to read: "Caution: This equipment is under automatic remote control of BAS" or equivalent to Consultant's approval.

## 3 Execution

### 3.1 EQUIPMENT IDENTIFICATION

- .1 Submit description of proposed equipment identification plates for engineer's approval.
- .2 Do not manufacture Lamecoid plates prior to receiving written approval from the engineer.
- .3 Lamecoid nameplates shall be applied to all electrical equipment including but not limited to the following:
  - .1 All electrical equipment enclosures for starters, disconnect switches, relay panels, panelboards, splitter troughs, transformers, thermal overload switches, etc.
- .4 Lamecoid nameplate fastening method as follows:
  - .1 Concrete or concrete block: Contact type cement (Note: Peel off type not acceptable).
  - .2 Plasterboard: Contact type cement (Note: Peel off type not acceptable).
  - .3 Equipment enclosures: Pop rivets. (Note: Screws not acceptable).
  - .4 Ceiling and T-Bar spline: Contact type cement (Note: Peel off type not acceptable).
- .5 Identify equipment as follows:
  - .1 Lamecoid nameplates installed on combination starters, magnetic starters, manual starter and all various systems controls, control panels, disconnect switches, shall contain the following information:
    - .1 Designated name of equipment.

- .2 Designated name of power source.
- .3 Branch circuit breaker number(s) where possible.
- .4 Voltage(s).
- .5 Size 8

**Example:**

***EXHAUST FAN NO. 5  
PANEL 1101 - CCT. NO. 17  
120V - 1 PH***

**EXAMPLE:**

***SUPPLY FAN NO. 3  
MCC 3101  
347/600V - 3 PH/4W***

- .2 Lamecoid nameplates are to be installed on all junction and/or pull boxes sized 150 mm x 150 mm (6" x 6") and larger indicating name of system, designated panel name and electrical characteristics where applicable.
- .3 Lamecoid nameplates are to be installed adjacent to each overcurrent device located in switchboards, CDP panels, MCC's, etc. They need only indicate designated name and/or number of equipment they feed. Each unused or spare overcurrent device is to be identified with a Lamecoid plate indicating it as being a spare. Size #5.

### **3.2 IDENTIFICATION OF JUNCTION BOXES, PULL BOXES, SPLITTER TROUGHS AND OUTLET BOXES**

- .1 All junction boxes and/or pull boxes, conduit fittings (and respective covers), complete with their respective cover plates as per the following:
  - .1 Colour code colors as noted in Part 2 of this section.
  - .2 Apply colour coding prior to pulling conductors into boxes.
  - .3 Inside and out where one colour is required, with cover plate painted completely.
  - .4 Where primary and secondary colours are indicated:
    - .1 Diagonally apply to each half of the inside and outside of box the primary and secondary colours.
    - .2 Diagonally apply to each half of the cover plate the primary and secondary colours.
    - .3 Provide a legend of colour coding used under Plexiglas. Locate in main electrical room.
- .2 All junction boxes and/or pull boxes, where not concealed, provide color identification discs fastened to the outside of the box, after architectural painting is complete.
- .3 Label ends of conduits (temperature sensor conduits, conduits through wall, etc.) red and white.
- .4 Voltage and Originating Source Identification
  - .1 Identification of electrical junction boxes, pull boxes, splitter troughs: smaller than 150 mm x 150 mm.
    - .1 Identify on the coverplate, using permanent indelible black marker the panel and circuit numbers contained with.
    - .2 Group phase conductors with associated neutral conductor.
  - .2 Identification of electrical junction boxes, pull boxes, splitter troughs: 150 mm x 150 mm and larger.
    - .1 Provide Lamecoid plate fastened to coverplate, indicating:
      - .1 Voltage, phase and Originating panel.
      - .2 Size 6.
      - .3 Example: "120/208 v, 3Ø, 4w, panel 'A'."
    - .2 Using permanent indelible black marker, identify the circuits contained within.

### **3.3 IDENTIFICATION OF SYSTEM CONTROL PANELS**

- .1 Provide Size 6 Lamecoid plate fastened to equipment enclosure indicating:
  - .1 System name.
  - .2 Example: "Building Automation System Control Panel".

### **3.4 IDENTIFICATION OF WIRING**

- .1 Identification of wiring:
  - .1 Identify wiring with permanent indelible identifying markings, either numbered or colored plastic tapes, on both ends of phase conductors of feeders and branch circuit wiring.
  - .2 Label each neutral conductor to indicate its associated phase conductors in each panelboard, distribution panel, pillbox and junction box it appears in. These labels are to be installed in a 'flagged' manner.
  - .3 All circuit conductors are to be individually tie wrapped to their corresponding labeled neutral conductor in all panelboards, pull boxes and junction boxes. Each neutral conductor is to be identified to indicate its corresponding phase conductors.
  - .4 Labeling of all branch circuit wiring including phase conductors, neutral, ground and/or bonding conductors to be done on both ends of all circuit wires plus in any junction and/or pull boxes located in between using approved product (refer to 2.3). These labels are to be installed in a 'flagged' manner around individual conductors.
  - .5 Indicate panel and circuit number i.e.: Panel '1101', cct. #10.

### **3.5 BAS IDENTIFICATION**

- .1 Provide engraved lamecoid nameplates clearly indicating the service and designation for the following devices:
  - .1 Duct and pipe mounted sensors.
  - .2 Control panels.
  - .3 Manual switches.
  - .4 Control valves.
- .2 Provide point I/O summary inside each control panel, specific for that control panel.

**END OF SECTION**

## **1 General**

### **1.1 GENERAL**

The General Conditions of the contract as well as provisions of Division 1 and Section 21 05 01 Mechanical General Requirements, Section 21 05 02 Mechanical Submittals and Section 21 05 03 Mechanical Contract Closeout are part of and to be read in conjunction with this Section.

### **1.2 REFERENCE STANDARDS**

- .1 In accordance with Section 21 05 01 Mechanical General Requirements.

## **2 Products**

### **2.1 BUILDING CONTROLLER (B-BC)**

- .1 Conform to BACnet Building Controller (B-BC) device profile as specified in ASHRAE/ANSI 135-2001, BACnet Annex L
- .2 Listed as a certified B-BC in the BACnet® Testing Laboratories (BTL) Product Listing.
- .3 All communication with operator workstation and all application controllers via BACnet®.
- .4 Provide UPS for each Building Controller
- .5 BACnet® Router: BACnet Building Controller that provides BACnet packet routing between BACnet networks located on BACnet® Local Area Network (LAN):
  - .1 Intelligent controller designed for connecting multiple BACnet networks together involving a variety of different physical network media. T
  - .2 Designed for BACnet BBMD and BACnet packet routing applications; it provides no control I/O points.
- .6 Fully programmable BACnet® Building Controllers that communicate on BACnet® Local Area Network (LAN) and BACnet® MS/TP Network (MS/TP):
- .7 Capable of providing global control strategies for the system based on information from any objects in the system regardless if the object is directly monitored by the controller or by another controller. The program that implements these strategies shall be completely flexible and user definable. Any systems utilizing factory preprogrammed global strategies that cannot be modified by field personnel on-site or downloaded via remote communications are not acceptable. Changing global strategies via firmware changes is also unacceptable.
- .8 Object-oriented programming using control function blocks, supporting BAS functions, 1000 Analog Values and 1000 Binary Values. All flowcharts shall be generated and automatically downloaded to controller. Programming tool shall be resident on workstation and the same tool used for all controllers.
- .9 Provide means to graphically view inputs and outputs to each program block in real-time as program is executing. This function may be performed via the operator's workstation or field computer.

- .10 Battery-backed real-time (hardware) clock functions.
- .11 Memory as needed to ensure high performance and data reliability. Battery shall retain static RAM memory and real-time clock functions for a minimum of 1.5 years (cumulative).
- .12 Global control algorithms and automated control functions should execute via 32-bit processor.
- .13 Installation includes memory-free gel-cell battery providing ongoing power conditioning and noise filtering for operation data integrity. It shall provide up to 5 minutes of powerless operation for orderly shutdown and data backup.
- .14 Schedules support a minimum of 250 BACnet® Schedule Objects and 250 BACnet® Calendar Objects.
- .15 Log as minimum 1000 trend logs. Any object in the system (real or calculated) may be logged. Sample time interval shall be adjustable at the operator's workstation.
  - .1 Logs may be viewed both on-site or off-site via remote communication.
  - .2 Building controller shall periodically upload trended data to networked operator's workstation for long term archiving if desired.
  - .3 Archived data stored in database format shall be available for use in third party spreadsheet or database programs.
- .16 Alarms generated within the system for any object change of value or state either real or calculated. This includes things such as analog object value changes, binary object state changes, and various controller communication failures.
  - .1 Each alarm may be dialed out.
  - .2 Alarm log shall be provided for alarm viewing. Log may be viewed onsite at the operator's terminal or off-site via remote communications.
  - .3 Controller must be able to handle up to 1500 alarm setups stored as BACnet® event enrollment objects - system destination and actions individually configurable.
- .17 Provide an adequate number of BC's to achieve the performance specified.
  - .1 Comprised of one or more independent, standalone, microprocessor-based BC's to manage the global strategies described in the System Software section.
  - .2 Have sufficient memory to support its operating system, database, and programming requirements.
  - .3 Share data between networked BC's.
  - .4 The operating system of the BC's shall manage the input and output communication signals to allow distributed controllers to share real and virtual object information, and allow central monitoring and alarms.
  - .5 BC's that perform scheduling shall have a real-time clock.
- .18 Communication: Each BC's support direct Ethernet. The BC's connected to the BACnet® network using the ISO 8802-3 (Ethernet) Data Link/ Physical layer protocol.
  - .1 A communications card shall perform BACnet® routing if connected to a network of Custom Application and Application Specific Controllers.
  - .2 Provide a service communication port using BACnet® Data Link/Physical layer protocol P-T-P for connection to a hand-held workstation/and/or modem.
  - .3 Secondary communication network support BACnet® MS/TP.

- .19 Communicate with other BACnet objects on the internetwork using the Read (Execute and Initiate) and Write (Execute and Initiate) Property services as defined in ASHRAE Standard 135-2001.
- .20 Serviceability: Provide diagnostic LEDs for power, communication, and processor. All wiring connections shall be made to field- removable, modular terminal strips or to a termination card connected by a ribbon cable.
- .21 Memory: Have as a minimum standard SRAM of 256 KB, standard DRAM of 1MB and standard non-volatile 1 MB of flash memory in lieu of EPROM. Memory user extendible through RAM chip sockets and SIMMs for future memory expansion.
- .22 Immunity to power and noise: Able to operate at 90% to 110% of nominal voltage rating and shall perform an orderly shutdown below 80% nominal voltage. Maintain all database information including BIOS and programming information in the event of a power loss for at least 72 hours. Operation shall be protected against electrical noise of 5 to 120 Hz and from keyed radios up to 5 W at 1 m.
- .23 Support the following BACnet functional groups: Clock, Event Initiation, COV Event Response, Files, Device Communication and Time Master.
- .24 Selected to provide a minimum of 15% spare I/O point/object capacity for each point/object type found at each location. If input /objects are not universal, 15% of each type is required. A minimum of one spare is required for each type of point/object used.
- .25 Inputs/Outputs.
  - .1 Inputs: Controller input/output board shall support dry contact, 0-5 VDC and 0-10 VDC- voltage, 4-20 mA- current and thermistor-resistive signal types on an individual basis for connecting any status or sensing device. Analog resolution shall be 10-bit A to D.
  - .2 Outputs: Controller input/output board shall support plug-and-play I/O modules or built in HOA modules configured with manual-auto-off override switch, potentiometer and input channel for feedback status or and unrelated analog or digital input. Output supported shall be 0-10 VDC. All HOA's shall be supervised.
  - .3 Diagnostics: Controller input/output board shall have red LEDs providing input status indication.
  - .4 External Power: Controller input/output board shall have one on-board 24 VDC terminal for directly connected active transducers.
- .26 Capability to create, delete and support the following BACnet® Objects:
  - .1 ANALOG INPUT, ANALOG OUTPUT AND ANALOG VALUE: Have the following writeable properties: Object Name; Object Value; Description; COV Increment; Out of Service and Units. In addition, support the properties: Device type; Reliability; Min./Max. Values; Update Interval and Resolution.
  - .2 BINARY INPUT, BINARY OUTPUT AND BINARY VALUE: Have the following writeable properties: Object Name; Object Value; Description; Polarity; Default Value; Min On/Off and Out of Service. In addition, support the properties: Device Type; Reliability; Active/Inactive Texts; Update Interval; Resolution; Change-of-State Time; Count Times and Time Reset.
  - .3 CALENDAR: Have the following writeable properties: Object Name; Object Value; Description; and Date List.



- .4 DEVICE: Have the following writeable properties: Object Name; Description; Location; and UTC Offset.
- .5 EVENT ENROLMENT: Have the following writeable properties: Object Name; Object Value; Description; Out-of-Service; Event & Notify Types; Parameters; Property Ref; Enable; and Notification Class.
- .6 FILE: Have the following writeable properties: Object Name; Description; File Type; and File Access.
- .7 LOOP (PID): Have the following writeable properties: Object Name; Object Value; Description; Polarity; Output and Input Refs.; Input Value & Units; Setpoint Value; PID Values; Bias; Write Priority and COV Increment. In addition, support the properties: Reliability; Update Interval; Proportional Constant & Units; Derivative Constant & Units.
- .8 NOTIFICATION CLASS: Have the following writeable properties: Object Name; Object Value; Description; Priority and Ack Required.
- .9 PROGRAM: This object shall have the following writeable properties: Object Name; Object Value and Description. In addition, this object shall support the property Reliability.
- .10 SCHEDULE: Have the following writeable properties: Object Name; Object Value and Description; Effective period; Schedule; Exception; Controlled Properties and Write Properties.
- .11 TREND LOG: Have the following writeable properties: Object Name; Description; Log Enable; Start/stop Times; Log Device Object Property; Log Interval; Stop When Full; Buffer Size; and Record Count.

## 2.2 CONTROLLER SOFTWARE

- .1 Provide the following applications software for building and energy management. All software applications shall reside and operate in the system controllers. Editing of applications shall occur at the operator workstation.
- .2 System Security: User access secured using individual security passwords and user names. Passwords restrict the user to the objects, applications, and system functions as assigned by the system manager. Record User Log On/Log Off attempts.
- .3 Scheduling: Provide the capability to schedule each object or group of objects in the system.
  - .1 Weekly Schedule: Provide separate schedules for each day of the week. Each of these schedules should include the capability for start, stop and optimal start. Each schedule may consist of up to 5 start-stop pairs or 10 events. When a group of objects are scheduled together, provide the capability to adjust the start and stop times for each member.
  - .2 Exception: Operator shall be able to designate an exception schedule for each of the next 365 days. After an exception schedule has executed, system shall discard and replace exception schedule with standard schedule for that day of the week.
  - .3 Holiday Schedules: Provide the capability for the operator to define up to 24 special or holiday schedules. These schedules may be placed on the scheduling calendar and will be repeated each year. The operator shall be able to define the length of each holiday period.
- .4 Alarm Reporting: Operator shall be able to determine the action to be taken in the event of an alarm. Alarms shall be routed to the appropriate workstations based on time and other conditions.

- .5 Remote Communication: The system shall have the ability via Ethernet to communicate in the event of an alarm using BACnet® Point-To-Point.
- .6 Maintenance Management: Monitor equipment status and generate maintenance messages based upon user-designated run-time, starts, and/or calendar date limits.
- .7 Sequencing: Provide application software to properly sequence the start and stop of boilers and pumps to minimize energy usage in the facility.
- .8 PID Control: A direct and reverse-acting PID (proportional-integral-derivative) algorithm and anti-windup shall be supplied. The algorithm shall calculate a time-varying analog value that is used to position an output or stage a series of outputs. The controlled variable, setpoint, and PID gains shall be user-selectable.
- .9 Staggered Start: This application shall prevent all controlled equipment from simultaneously restarting after a power outage.
- .10 Energy Calculations: Provide software to allow instantaneous power (e.g., kW) or flow rates (e.g., L/s) to be accumulated and converted to energy usage data. System shall calculate a sliding-window average (rolling average). Operator shall be able to adjust window interval to 15 minutes, 30 minutes, or 60 minutes.
- .11 Anti-Short Cycling: All binary output objects shall be protected from short cycling. This feature shall allow minimum on-time and off-time to be selected.
- .12 Demand Limiting.
  - .1 System shall monitor building power consumption from building power meter pulse generator signals or from building feeder line watt transducer or current transformer.
  - .2 When power consumption exceeds adjustable levels, system shall automatically adjust setpoints, de-energize low-priority equipment, and take other programmatic actions to reduce demand. When demand drops below adjustable levels, system shall restore loads as specified.
- .13 On/Off Control with Differential. Provide an algorithm that allows a binary output to be cycled based on a controlled variable and setpoint. The algorithm shall be direct-acting or reverse-acting, and incorporate an adjustable differential.
- .14 Run-time Totalization: Provide software to totalize run-times for all binary input objects. A high run-time alarm shall be assigned, if required, by the operator.
- .15 Programming
  - .1 Provide sufficient internal memory for the specified sequences of operation and trend logging.
  - .2 Provide a minimum of 25% of available memory free for future use.
  - .3 Point/object Naming: System point/object names shall be modular in design, allowing easy operator interface without the use of a written point/object index. Refer to Section 25 05 01
- .16 Software Programming
  - .1 Provide programming for the system and adhere to the sequences of operation provided.

- .2 Provide all other system programming necessary for the operation of the system, but not specified in this document. Imbed into the control program sufficient comment statements to clearly describe each section of the program. The comment statements shall reflect the language used in the sequences of operation. Use the appropriate technique based on the following programming types:
  - .1 Text-based:
    - .1 must provide actions for all possible situations
    - .2 must be modular and structured
    - .3 must be commented
  - .2 Graphic-based
    - .1 must provide actions for all possible situations
    - .2 must be documented
  - .3 Parameter-based
    - .1 must provide actions for all possible situations
    - .2 must be documented.
- .17 Operator Interface
  - .1 Standard Graphics. Provide graphics for all mechanical systems and floor plans of the building. This includes each glycol water system, hot water system, boiler, air handler and all terminal equipment. Point/object information on the graphic displays shall dynamically update. Show on each graphic all input and output points/objects for the system. Also show relevant calculated points/objects such as setpoints
  - .2 Provide all the labor necessary to install, initialize, start up, and troubleshoot all operator interface software and their functions as described in this section. This includes any operating system software, the operator interface database and any third-party software installation and integration required for successful operation of the operator interface

## 2.3 ADVANCED APPLICATION CONTROLLERS (B-AAC)

- .1 Provide an adequate number of Programmable Advanced Application Controllers to achieve the performance specified. Each of these panels shall meet the following requirements;
  - .1 Have sufficient memory to support its operating system, database, and programming requirements.
  - .2 The operating system of the Controller shall manage the input and output communication signals to allow distributed controllers to share real and virtual object information, and allow central monitoring and alarms.
  - .3 All equipment that requires scheduling shall be scheduled in that equipment's controller.
  - .4 Communicate with other BACnet objects on the internetwork using the Read (Execute and Initiate) and Write (Execute and Initiate) Property services as defined in Clauses 15.5 and 15.8, respectively, of ASHRAE Standard 135.
  - .5 Both firmware and controller database shall be loadable over the network.
- .2 Communication.
  - .1 Reside on a BACnet network using BACnet® Local Area Network (LAN) or BACnet® MS/TP Network (MS/TP)
  - .2 Provide a service communication port using BACnet Data Link/ Physical layer protocol for connection to portable operator's workstation and allow access to the entire network.

### **3 Execution**

#### **3.1 GENERAL**

- .1 Locate controllers in lockable enclosures as per Section 25 05 01 BAS: General Requirements

#### **3.2 PROGRAMMING**

- .1 Provide all programming necessary for a fully functioning system.
- .2 The control strategy for each system shall be performed by software within the control unit. Refer to the Control Drawings for the sequence of operation for each system.
- .3 Tune each temperature control loop to provide control within +/- 0.5°C unless otherwise indicated.
- .4 Provide time schedules for all start/stop points.
- .5 Provide and program high and low limit alarms on all analog input points.
- .6 Program the level of annunciation for each alarm to the requirements of the Owner.
  - .1 Local to specific network control unit(s).
  - .2 Operators Workstations.
  - .3 Alarm printer.
- .7 Outside air temperature to show on all screens.
- .8 Program for trend logs as specified below.
- .9 Program system to enable two types of all points log be printed: Log 1 - all points except room temperature and room control valves. Log 2 - all room temperature and room control valves.
- .10 Point Label to be as per drawing. Submit labels with shop drawings.

**END OF SECTION**

## **1 General**

### **1.1 GENERAL**

The General Conditions of the contract as well as provisions of Division 1 and Section 21 05 01 Mechanical General Requirements, Section 21 05 02 Mechanical Submittals and Section 21 05 03 Mechanical Contract Closeout are part of and to be read in conjunction with this Section.

### **1.2 REFERENCE STANDARDS**

- .1 In accordance with Section 21 05 01 Mechanical General Requirements.

## **2 Products**

### **2.1 GENERAL**

- .1 External trim materials to be corrosion resistant. Internal parts to be assembled in vibration-proof, assembly.
- .2 Terminations: use standard conduit box with slot screwdriver compression connector block unless otherwise specified.
- .3 Transmitters to be unaffected by external transmitters (e.g. walkie talkies).
- .4 Account for hysteresis, relaxation time, maximum and minimum limits in applications of sensors and controls.
- .5 Devices to be installed in user occupied space must not exceed Noise Criteria (NC) of 35. Noise generated by any device must not be detectable above space ambient conditions.

### **2.2 TEMPERATURE SENSORS**

- .1 General: except for Terminal unit box control to be resistance or thermocouple type to following requirements:
  - .1 Thermocouples: to be limited to temperature range of 200° C and over. RTD's: 100 ohm at 0° C (plus or minus 0.2 ohms) platinum element with strain minimizing construction, 3 integral anchored leadwires. Coefficient of resistivity: 0.00385 ohms/ohm ° C.
  - .2 Sensing element: hermetically sealed.
  - .3 Stem and tip construction: copper or type 304 stainless steel. Time constant response: less than 3 seconds to temperature change of 10° C.
- .2 Thermistor:
  - .1 Monitoring Range.
    - .1 -40° C to 55° C where exposed to outside air.
    - .2 -5° C to 55° C elsewhere.
  - .2 Factory Calibration Point 25° C with accuracy of Calibration Point +/- 0.3° C.
  - .3 Stainless steel probe.
- .3 Resistance Temperature Detectors (RTD's):
  - .1 Monitoring Range.
    - .1 -1° C to 49° C for ducts.
    - .2 21° C to 104° C for hot water and glycol systems.

- .2 Factory Calibration Point 21° C.
- .3 Accuracy Calibration Point.
  - .1 For -7° C to 49° C type +/- 0.7° C.
  - .2 For 21° C to 104° C type +/- 1.1° C.
  - .3 Platinum or Nickel Wire Sensor.
- .4 Duct Mounted: Suitable for insertion at any angle, minimum sensor probe length 18" or as indicated.
- .5 Immersion wells: NPS 3/4, stainless steel spring loaded construction, with heat transfer compound compatible with sensor. Insertion length 100 mm or as indicated.
- .6 Averaging duct type: continuous filament (Numerous sensors encapsulated along length of probe not acceptable) with immersion length of 1800 mm (72") minimum. Probe to be bent, at field installation time, to a minimum radius of 100 mm (4") at any point along the probe length without degradation in performance.

### 2.3 TEMPERATURE TRANSMITTERS

- .1 Input circuit: to accept 3-lead, 100 ohm at 0° C, platinum resistance detectors type sensors.
- .2 Power supply: 575 ohms at 24 V DC into load of 575 ohms. Power supply effect less than 0.01° C per volt change.
- .3 Output signal: 4 - 20 mA into 500 ohm maximum load.
- .4 Input and output short circuit and open circuit protection.
- .5 Output variation: less than 0.2 % of full scale for supply voltage variation of plus or minus 10 %.
- .6 Combined non-linearity, repeatability, hysteresis effects: not to exceed plus or minus 0.5 % of full scale output.
- .7 Maximum current to 100 ohm RTD sensor: not to exceed 25 mA.
- .8 Integral zero and span adjustments.
- .9 Temperature effects: not to exceed plus or minus 1.0 % of full scale/ 50° C.
- .10 Long term output drift: not to exceed 0.25 % of full scale/ 6 months.
- .11 Transmitter ranges: Select narrowest range to suit application from following:
  - .1 - 50° C to +50° C, plus or minus 0.5° C.
  - .2 0 to 100° C, plus or minus 0.5° C.
  - .3 0 to 5° C, plus or minus 0.25° C.
  - .4 0 to 25° C, plus or minus 0.1° C.
  - .5 10 to 35° C, plus or minus 0.25° C.

## 2.4 ELECTRICAL RELAYS

- .1 Double voltage, DPDT, plug-in type with termination base
- .2 Coils: rated for 120 VAC or 12 V DC. Other voltage: provide transformer
- .3 Contacts: rated at 6 amps at 120 VAC
- .4 Relay to have visual status indication
- .5 Acceptable material: Eaton Model # XRR2D12 and plug-in base.

## 2.5 ANALOG CURRENT SENSORS

- .1 Purpose: measure line current and produce proportional signal in one of following ranges:
  - .1 4-20 mA DC
  - .2 0-5 volt DC
  - .3 2-10 volts DC
- .2 Solid core AC current sensors.
- .3 Frequency insensitive from 10 - 80 Hz.
- .4 Accuracy to 0.5% full scale
- .5 Zero and span adjustments. Field adjustable range to suit motor applications.
- .6 Adjustable mounting bracket.
- .7 Acceptable material: Greystone Model CS-450-1.

## 2.6 CONTROL VALVES

- .1 NPS 2 and under.
  - .1 Class 250.
  - .2 Bronze body and trim.
  - .3 Screwed ends.
- .2 NPS 2 1/2 and over.
  - .1 Class 125.
  - .2 Cast iron body.
  - .3 Bronze trim.
  - .4 Flanged or roll grooved ends.
- .3 Three-Way Mixing Control Globe Valve:
  - .1 Spring return for "fail safe" in normally open position.
  - .2 Cv rating port A to AB to equal port B to AB
  - .3 Leakage: A port 0%. B port 0%
  - .4 Linear characteristics.
  - .5 Maximum pressure drop across any control valve shall not exceed (4 psi) unless otherwise specified.
  - .6 Acceptable Material
    - .1 Siebe VK-7313
    - .2 Belimo G3 + LF/AF Three way globe valves.

## **2.7 ELECTRONIC/ELECTRIC VALVE ACTUATORS**

- .1 Construction: steel, cast iron, aluminum.
  - .1 Control voltage: 0-20V DC or 24V AC.
  - .2 Positioning time: to suit application. 90 sec maximum
  - .3 Spring return to normal position as indicated
- .2 Size operators to ensure tight shut off when subjected to maximum system differential pressure
- .3 Minimum close off rating shall be 200 kPa (30 psi).

## **3 Execution**

### **3.1 GENERAL**

- .1 Temperature transmitters, humidity transmitters, controllers, relays: install in NEMA I enclosure or as required for specific applications. Provide for electrolytic isolation in all cases when dissimilar metals make contact.
- .2 Support field-mounted transmitters, sensors on pipe stands or channel brackets.
- .3 Duct and AH unit mounted devices: Seal duct and Ah unit to prevent air leakage.
- .4 Wall mounted devices: Install on plywood panel properly attached to wall.
- .5 Duct mounted devices: On insulated ducts, mount devices and associated wiring on standoffs.

### **3.2 PUMP STATUS**

- .1 Pump status: determined via AI points connected to current operated sensors.
- .2 Auxiliary contacts on motor starters will not be acceptable for this function.

### **3.3 BAS CONTROL COMPONENTS AND MOTOR STARTERS**

- .1 AC Current sensors are supplied and installed by Section 25 30 02 BAS Field Control Devices.
- .2 Relays and Relay Bases are supplied and installed by Section 25 30 02 BAS Field Control Devices.

### **3.4 TEMPERATURE SENSORS**

- .1 Stabilized to such a level as to permit on-the-job installations that will require minimum field adjustments or calibration.
- .2 Assemblies readily accessible and adaptable to each type of application in such a manner as to allow for quick, easy replacement and servicing without special tools or skills.



- .3 Locate duct sensors locations to sense the correct temperature of the air only, and not be located in dead air spaces. The location shall be within the vibration and velocity limits of the sensor. Where an extended surface element is required to properly sense the average temperature it shall be securely mounted within the duct to measure the best average temperatures. Elements shall be thermally isolated from brackets and supports to respond to air temperature only. Sensor element to be supported separately and not connected to coils or filter racks.
- .4 Install wells in the piping at elbows where piping is smaller than the length of the well to effect proper flow across the entire area of the well. Well shall not restrict flow area to less than 70 percent of line-size-pipe normal flow area.

### **3.5 TEMPERATURE SENSORS**

- .1 Stabilize to ensure minimum field adjustments or calibrations
- .2 Locate duct mounted humidity sensors such that the sensing element is between one third and two thirds the distance across the unit interior from any duct wall.
- .3 To be readily accessible and adaptable to each type of application so as to allow for quick easy replacement and servicing without special tools or skills.
- .4 Duct installations:
  - .1 Do not mount in dead air space
  - .2 Location to be within sensor vibration and velocity limits
  - .3 Securely mount extended surface sensor used to sense average temperature
  - .4 Thermally isolate elements from brackets and supports so as to respond to air temperature only
  - .5 Support sensor element separately from coils, filter racks
- .5 Averaging duct type temperature sensors:
  - .1 Sensor length to be not less than 1000 mm per square meter of duct cross-sectional area
  - .2 Use multiple sensors where single sensor does not meet minimum length ratio. Wire multiple sensors in series for freeze protection applications
  - .3 Wire multiple sensors separately for temperature measurement
  - .4 Use either software averaging algorithm to derive overall average for control purposes or separate inputs, based on site requirements
- .6 Thermowells: install for piping installations. Where pipe diameter is less than well insertion length, locate well in elbow. Thermowell to restrict flow by less than 30%.

### **3.6 FIELD MOUNTED TRANSMITTERS AND SENSORS**

- .1 Support properly on pipe stands or channel brackets.
- .2 Install wall mounted devices on plywood panel attached properly to wall.

**END OF SECTION**

## **1 General**

### **1.1 GENERAL**

The General Conditions of the contract as well as provisions of Division 1 and Section 21 05 01 Mechanical General Requirements, Section 21 05 02 Mechanical Submittals and Section 21 05 03 Mechanical Contract Closeout are part of and to be read in conjunction with this Section.

### **1.2 REFERENCE STANDARDS**

.1 In accordance with Section 21 05 01 Mechanical General Requirements.

### **1.3 WIRING**

- .1 If departures from the contract drawings are deemed necessary, details of such departures, including changes in related portions of the project and the reasons therefore, shall be submitted with drawings for approval.
- .2 Incorporate surge transient protection in the design of the system to protect all electrical components in all control equipment.

### **1.4 SYSTEM DESCRIPTION**

.1 Electrical: Hard wiring between field control devices and BAS field panels.

## **2 Products**

### **2.1 CONTROL SYSTEM WIRE AND CABLE**

- .1 Cable jacket:
  - .1 FT6 jacket rated and bear the following labels: CSA 300 volts and FT6.
  - .2 FT4 jacket rated and bear the following labels: CSA 600 volts and FT4.
  - .3 Labeled with the following information, as a minimum:
    - .1 Cable type.
    - .2 FT rating.
    - .3 Temperature rating.
    - .4 CSA number.
    - .5 Rated voltage.
    - .6 Gauge and number of conductors.
  - .4 Application:
    - .1 Control wiring to 600 volt starters to be FT4 in conduit.
    - .2 All control wiring in conduit may be FT4.
    - .3 All other control wiring to be FT6.
    - .4 Colored as follows:

<b>System Description</b>	<b>Jacket Colour</b>
BAS	Yellow

- .2 Below 50V control wiring:
  - .1 Minimum No. 14 stranded.
  - .2 Minimum two conductor No. 18 AWG solid copper or No. 20 AWG, stranded twisted pair for field wiring of each digital device.

- .3 Minimum No. 22 AWG solid copper for multi-conductor wiring having four or more conductors.
- .4 Minimum two conductor No. 18 AWG, solid copper, or No. 20 AWG, stranded twisted pair, shielded for field wiring of each analog input.

## 2.2 BUILDING WIRES

- .1 Stranded, soft drawn copper with RW90 XLPE insulation rated for a minimum of 600 VAC for all conductors (phase, neutral, bond, isolated ground).
- .2 #12 AWG minimum wire size.
- .3 Green colored RW90 X-link insulation for Grounding and bonding conductors.
- .4 Multi-conductor AC-90 cables containing a single white colored conductor are not to be used where more than one neutral conductor is required.

## 2.3 JUNCTION, PULL BOXES AND CABINETS

- .1 Welded steel construction with screw-on flat covers for surface mounting.
- .2 Covers with 25 mm (1 inch) minimum extension all around, for flush-mounted pull and junction boxes.
- .3 Junction boxes larger than 120 mm (4 11/16") to have a bonding terminal strip installed.
- .4 Cabinets:
  - .1 Finish: ASA- 61 grey enamel.
  - .2 Complete with bonding terminal strip.
  - .3 Type D: 1.6 mm steel cabinet, built for surface or flush mounting. Flush cover lip 25 mm all around. Complete with screw on cover.
  - .4 Type E: 1.6 mm steel cabinet, surface mount. Formed steel hinge with pull ring catch.
  - .5 Type T: 1.6 mm steel cabinet, 1.9 mm cover, latch lock, 2 keys.
- .5 Size to suit the wiring for the control system and to allow for future expansion capabilities specified for the system.

## 2.4 OUTLET AND CONDUIT BOXES

- .1 100 mm (4") square or larger outlet boxes as required for special devices.
- .2 Blank cover plates for boxes without wiring devices.
- .3 120 V outlet boxes for 120 V switching devices.
- .4 Combination boxes with barriers where outlets for more than one system or voltage are grouped.
- .5 Where tile rings are installed, they must be the welded type with square corners (Rounded corners will not be acceptable). For single device installations use Iberville BC52-C-49XX. For two device installations use Iberville # 52-C-52-XX. Select appropriate depth of tile ring to suit application.

- .6 Adjustable type tile rings such as Iberville # 52C-ADJ are not permitted on this project.
- .7 Sheet Steel Device Boxes:
  - .1 One Device, Flush Installation, Suitable for Armoured Cable Entry : Electro-galvanized steel single, flush device boxes for use in dry flush installation, pressed steel, non-gangable, minimum size 75 mm (3") x 57 mm (2-1/4") x 63 mm (2.5") deep, minimum volume of 245 cubic centimetres (15 cu.in.), (Similar to Iberville # 1504-LSSAX).
  - .2 One or Two Device, Flush Installation, Suitable for Conduit Entry: Electro-galvanized steel single, flush device boxes for use in dry flush installation, shall be pressed steel, minimum size 100 mm (4") square x 54 mm (2 1/8") deep, minimum volume of 490 cubic centimetres (30 cu.in.) (Similar to Iberville # 52171-K). Provide single device square cornered tile cover (Similar to Iberville # BC52-C-49XX) or two device square cornered tile covers (Similar to Iberville # 52-C-52-XX).
  - .3 Provide an outlet box for all control outlets complete with single gang raised tile ring and stainless steel cover plate, unless noted otherwise. Minimum dimensions as follows: 100 x 100 x 53 mm (4" x 4" x 2 1/8") deep, minimum volume of 490 cubic centimetres (30 cu.in.) (Similar to Iberville # 52171-K).
  - .4 100-mm square or octagonal outlet boxes for lighting fixture outlets.
- .8 Surface Mount Conduit Boxes
  - .1 Cast FS aluminum boxes with factory-threaded hubs and mounting feet for surface wiring of switches and receptacles.
  - .2 Metal type "FS" device plates to be used on all type "FS" boxes unless noted otherwise.
- .9 Mounting Brackets
  - .1 Provide box mounting brackets for the installation of multiple boxes for drywall partitions, complete with tile rings.
  - .2 Acceptable material: Caddy RBS Type (16 or 24 as required).
- .10 Fittings – General
  - .1 Knock-out fillers to prevent entry of foreign materials.
  - .2 Double locknuts and insulated bushings on sheet metal boxes.

## **2.5 CONDUITS**

- .1 Rigid galvanized steel threaded conduit.
- .2 Electrical metallic tubing (EMT) with couplings.
- .3 Liquid-tight flexible metal conduit.
- .4 Metal flexible conduit.

## **2.6 WIRE AND BOX CONNECTORS 0-1000V**

- .1 Spring type pressure type connectors for all branch circuit wiring sized #10 AWG and smaller. Current carrying parts are to be made of copper or copper alloy and be complete with an appropriate size insulating cap. Cap is to completely fit or cover all enclosed conductors as required, with current carrying parts of sized to fit conductors as required.

## 2.7 CONDUIT FASTENINGS

- .1 Fasten conduit to building construction or support system using straps, as follows:
  - .1 One-hole steel straps to secure surface conduits and cables 35 mm (1-1/4") and smaller.
  - .2 Two hole steel straps for conduits and cables 41 mm (1-1/2") and larger.
- .2 Beam clamps to secure conduits to exposed steelwork.
- .3 Channel type supports for one or more conduits.
  - .1 U shape, minimum size 45 mm x 45 mm, 3 mm thick, surface mounted as required.
- .4 10 mm (3/8") diameter threaded rods to support suspended channels.

## 2.8 CONDUIT FITTINGS

- .1 Fittings: manufactured for use with conduit specified. Coating same as conduit.
- .2 Set screw, galvanized steel couplings for thinwall type EMT conduits
- .3 Top or side connections to equipment enclosures equipped with sprinkler hoods
  - .1 Conduits with rain tight EMT connectors.
  - .2 Equipped with a rubber "O" Ring gasket.
- .4 Connectors for thinwall type EMT conduits
  - .1 Set screw, galvanized steel, complete with case hardened steel locknuts.
  - .2 Provide insulated throats on connectors up to and including 27 mm (1").
  - .3 Provide metal thread on bushings on all EMT connectors sized 35 mm (1-1/4") or larger.
- .5 Two-screw, steel type connectors for armored cable similar to T & B #3301, 3312. Provide insulating bushings (anti-shorts) for armored cable connectors. The use of "snap-in" type connectors is not permitted.
- .6 Nylon insulated, steel or malleable iron type connectors for flexible metal conduit similar to T & B Tite-Bite #3115 thru 3124. Provide insulating bushings (anti-shorts) for flexible metal conduit connectors. Plastic thread on bushings to be installed on all flexible metal conduit connectors sized 35 mm (1-1/4") or larger.
- .7 Liquid-tight flexible metal conduit fittings:
  - .1 Specifically listed for liquid tight flexible metal conduit.
  - .2 Steel type, to match conduit size.
  - .3 Fittings must incorporate a threaded grounding cone, a steel or plastic compression ring, and a gland for tightening.
  - .4 Safe edge ground type.
  - .5 Connectors shall have insulated throats.
  - .6 Standard of Acceptance: T & B #5300 series.

## 2.9 GROUNDING AND BONDING

- .1 Insulated grounding conductors: green, insulation to this section.
- .2 Ground bar: copper, size as indicated, complete with insulated supports, fastenings, connectors.

- .3 Non-corroding accessories necessary for grounding system, type, size, material as indicated, including but not necessarily limited to:
  - .1 Grounding and bonding bushings.
  - .2 Protective type clamps.
  - .3 Bolted type conductor connectors.
  - .4 Thermit welded type conductor connectors.
  - .5 Bonding jumpers, straps.
  - .6 Pressure wire connectors.
- .4 All Ground Busbars: 6 mm electro-tin plated copper, complete with insulators, stainless steel brackets and fasteners, Erico # TMGB-A29L41PT

### **3 Execution**

#### **3.1 GENERAL**

- .1 Install all work in accordance with authorities having jurisdiction and manufacturer's requirements. In case of conflicting requirements, the more stringent shall apply.
- .2 Install in a neat and ordered manner.
- .3 Colour Coding: Refer to 25 05 032 BAS Identification.
- .4 Fully enclose or properly guard electrical wiring, terminal blocks, high voltage above 70 V contacts and mark to prevent accidental injury.
- .5 Check factory connections and joints. Tighten where necessary to ensure continuity.
- .6 Holes through exterior wall and roofs: flash and make weatherproof.
- .7 Where equipment, ducts or pipes are insulated, install control wiring on stand-offs.
- .8 Do not cover with mechanical insulation.
- .9 Secure approval for damper motor locations and supports.
- .10 Run parallel or perpendicular to building lines. When installed in a wall cavity, conduit is to be installed vertically from outlet box to ceiling space, not run in an angled manner through the studs.
- .11 Run conduits in flanged portion of structural steel, where possible.
- .12 Group conduits wherever possible.
- .13 Do not pass conduits through structural members except as indicated.
- .14 Do not locate conduits closer than 75 mm (3 inch) parallel to hot water lines with a minimum of 25 mm (1 inch) at crossovers.
- .15 Support electrical systems raceway independent of any type of suspended ceiling support rods, wires, etc. Toggle bolts shall not be used in Gypsum board construction.

- .16 Do not install horizontal conduits runs in masonry walls.
- .17 Do not install conduits in terrazzo or concrete toppings.

### **3.2 WIRE AND BOX CONNECTORS 0-1000V FOR CONTROL SYSTEMS**

- .1 Secureness tests in accordance with CSA C22.2 No.65.
- .2 Remove insulation carefully from ends of conductors.
- .3 “Plier-tightened” all wire connectors

### **3.3 INSTALLATION OF WIRES**

- .1 In conduit systems in accordance this section.
- .2 All stranded conductors, (neutrals, bonds and phase conductors) prior to terminating under device bolts i.e., circuit breakers, light switches, receptacles etc., to be twisted together so as to form a single conductor.
- .3 All branch circuit phase conductors feeding receptacles via junction and/or outlet boxes are to be complete with "pigtail" type leads to ensure minimal disruption of receptacle circuits if receptacles are removed for future maintenance.
- .4 Where the application of colored tape is permitted, apply as follows:
  - .1 Both ends of the conductor must be taped for all installed segments.
  - .2 Each location where the conductor is visible, i.e.; all junction and pull boxes.
  - .3 A minimum of 305 mm (12”) of tape to be applied for all phase conductors.
  - .4 All neutral, grounds and/or bond conductors must be taped for their entire visible length in all enclosures.
- .5 Conductor tie-wrapping:
  - .1 All circuit conductors are to be individually tie wrapped to their corresponding labeled neutral conductor in all panelboards, pullboxes and junction boxes. Suitable slack conductor length should be left to enable the ability to clamp the ground detector around the individually tie-wrapped circuit conductor and its corresponding labeled neutral. This wiring method is to be neat and of good workmanship quality.
  - .2 The tie-wrapping of the neutral with its respective phase conductors is to be made at the closest point of entry into panelboards, pullboxes and junction boxes.
- .6 Final connection
  - .1 Provide separate pig-tail type leads in each receptacle outlet box for final connections to receptacles. Only connect these pig-tail leads to the phase and associated neutral conductors.
- .7 Testing by this subcontractor
  - .1 After all electrical wiring has been completed, test the grounded electrical distribution system to ensure there are no grounds, shorts and capacitive leakage in the system.
    - .1 All feeders or branch circuits which do not have neutral conductors are to have their respective phase conductors tye-wrapped together in accordance to the methods described previously.
    - .2 Test circuits and neutrals.

### 3.4 INSTALLATION OF PATHWAYS

- .1 EMT type conduit wall-stub complete with flush installed device box are required in all partitions, regardless of construction material.
- .2 Turned out stubs into accessible ceiling space within the same room as the outlet box or as required for routing to control devices and/or control panels, complete with nylon insulated throat, Arlington bushing or threaded type bushing. Minimum size to be 27 mm (1 inch).
- .3 Ensure that both the device box and accompanying conduit sleeve are bonded to ground, as follows:
  - .1 Outlet box installed in partition utilizing metal studs, adjacent to receptacle box: Provide a #12 green insulated RW90 bonding conductor between receptacle device box and control outlet device box. Provide a push-on non-metallic insulated bushing on the end of the conduit stub, similar to Arlington Series EMT (T&B Insuliner sleeves not acceptable).
  - .2 Outlet box not otherwise bonded to ground: Where bonding connection is available from an overhead source (junction box, cable tray, etc.), provide a #12 green insulated RW90 bonding conductor from the bonding connection, through the conduit sleeve to the device box. Terminate bond wire at the device box. Provide a push-on non-metallic insulated bushing on the end of the conduit stub similar to Arlington Series EMT (T&B Insuliner sleeves not acceptable).
- .4 When cables are required to pass through a partition separating a corridor from a room, or between rooms, EMT type conduit sleeves are required, sized in accordance with the information contained in this section. Sleeves shall be installed into accessible ceiling space, complete with nylon insulated throats or threaded type bushings. Provide a bonding bushing for all conduit sleeves. Seal the ends of all conduits after installation of cables. Firestop where required to maintain a fire resistance rating. Smoke seal where required.
- .5 Provide suitably sized electrical junction boxes for all wiring supplied by this contractor, regardless of system voltage. This electrical box will contain all electrical connections associated with wiring for all electrical systems.
- .6 When cables are required to pass from the cable tray through a partition separating the corridor from a room, two (2) 53 mm (2 inch) EMT type conduits are required. Conduits shall extend into the room accessible ceiling space; complete with nylon insulated throats or threaded type bushings. Provide a bonding conductor, connected to the cable tray for all conduits. Seal the ends of all conduits after installation of cables. Firestop where required to maintain a fire resistance rating. Smoke seal where required.
- .7 Where grouping of various systems outlets or multiple type outlets in drywall type construction is required, the use of box mounting brackets as manufactured by Caddy #RBS16 or #RBS24 are to be installed between and secured to both metal studs. Secure brackets to metal studs using low profile sheet metal screws. Install suitable sized 102 mm (4") square and/or 119 mm (4 11/16") boxes complete with single gang raised tile rings.
- .8 All surface wiring installed in rooms and/or other areas not having any hung, or drop type ceilings, or where otherwise installed on, or to wall surfaces etc., are to always be contained or sleeved in EMT type conduits.



- .9 All non-concealed, surface type wiring installed on either ceilings and/or walls, is to also be sleeved in EMT type conduit.
- .10 All concealed wiring routed through rooms with drywall or other inaccessible ceiling types are to be installed in a conduit system. The installation of access doors or recessed light fixtures in these areas does not change these types of ceilings from inaccessible to accessible.
- .11 Provide suitably sized EMT conduit sleeves for controls system cables which pass through common walls between classrooms, workrooms, etc. Bond all sleeves to ground.
- .12 Pull boxes are to be sized in conformance with CEC Rule 12-3036, unless noted otherwise. In addition, pull boxes installed on conduits used for the installation of control systems for straight pulls, shall conform to the following minimum requirements:
  - .1 Minimum size of pull box: 150 x 150 x 100 mm (6 x 6 x 4 inch)
  - .2 35 mm (1-1/4 in): 150 wide x 510 long x 100 deep (6 x 20 x 4 inch).
  - .3 41 mm (1-1/2 in): 200 wide x 686 long x 100 deep (8 x 27 x 4 inch).
  - .4 50 mm (2 in): 200 wide x 914 long x 150 deep (8 x 36 x 4 inch).
  - .5 75 mm (3 in): 300 wide x 1220 long x 100 deep (12 x 48 x 6 inch).
  - .6 100 mm (4 in): 375 wide x 1525 long x 200 deep (15 x 60 x 8 inch)
- .13 In addition to the above requirements, BAS control circuit wiring 50 volts and less is to be installed as follows:
  - .1 Extend EMT conduits to within 760 mm (30 inches) of all various control devices associated with the operation of any given piece of mechanical equipment or device they might feed.
  - .2 For final connection between end of EMT conduit and applicable control device, use liquid tight metal type conduit complete with matching liquid tight type connectors.
  - .3 Bonding conductors are not required in flexible metal conduits where the conduit terminates in a non-metallic electrical box.

### **3.5 INSTALLATION OF HANGERS AND SUPPORTS**

- .1 BAS control cables installed within accessible ceiling spaces and not installed in a conduit system are to be secured directly to the steel deck, above the support structure. Provide supports at maximum 1200 mm (48") intervals.
- .2 Secure equipment to hollow and solid masonry, tile and plaster surfaces with lead anchors.
- .3 Secure equipment to poured concrete with expandable inserts.
- .4 Support equipment, conduit or cables using clips, spring-loaded bolts, cable clamps designed as accessories to basic channel members.
- .5 Fasten exposed conduit or cables to building construction or support system using straps.
  - .1 One-hole steel straps to secure surface conduits and cables 35 mm (1-1/4 inch) and smaller.
  - .2 Two-hole steel straps for conduits and cables 41 mm (1-1/2 inch) and larger.
  - .3 Beam clamps to secure conduit to exposed steelwork.

- .6 Securely fastened EMT in place within 1 meter (40 inches) of each outlet box, junction box, cabinet, couplings, fittings and changes in direction and the spacing between supports as follows:
  - .1 Not greater than 1500 mm (5') for 16 mm (1/2") and 21 mm (3/4") EMT
  - .2 Not greater than 1800 mm (6') for 27 mm (1") and 35 mm (1-1/4") EMT
  - .3 Not greater than 3050 mm (10') for 41 mm (1-1/2") EMT or larger.
  
- .7 Suspended supports systems.
  - .1 Support single or multiple cables or conduits on a common steel support channel system supported by 10 mm (3/8") diameter threaded rod hangers, washers and nuts where direct fastening to building construction is impractical. Channel is to be sandwiched between nuts and washers located on both upper and underside portions of channels.
  - .2 Do not support a single conduit using a threaded rod and a conduit clip. This is not an acceptable means of installation as no lateral support is provided.
  
- .8 For surface mounting of single and multiple conduits use channels. Channels are to be securely attached to hangers with the maximum spacing not greater than:
  - .1 Conduits of one size only:

.1 16 mm to 21 mm ( 1/2" to 3/4") conduit	1524 mm (60")
.2 27 mm & 35 mm (1" to 1 1/4") conduit	1980 mm (78")
.3 41 mm (1 1/2") & larger conduit	3050 mm (120")
  - .2 Conduits of mixed size: Arrange supports so that maximum spacing of supports conforms to above, based on smallest conduit diameter.
  
- .9 All suspended types of junction and pull boxes are to be supported using a minimum of 10 mm (3/8") threaded rod complete with nuts and flat washers. Secure threaded rods to boxes using one flat washer and nut installed on both sides of box. Provide as follows:
  - .1 One rod required for all types of boxes sized 150 x 150 mm (6 x 6 inches) or smaller.
  - .2 Two rods required for all types of boxes larger than 150 x 150 mm (6 x 6 inches) but less than 304 x 304 mm (12 x 12 inches)
  - .3 Four rods required for all types of boxes 304 x 304 mm (12 x 12 inches) and larger.
  
- .10 Cut-off all excess threaded rod to within 13 mm (1/2") of channel bottom.
  
- .11 Provide metal brackets, frames, hangers, clamps and related types of support structures where indicated or as required to support conduit and cable runs.
  
- .12 Ensure adequate support for raceways and cables dropped vertically to equipment where there is no wall support.
  
- .13 Do not use wire lashing or perforated strap to support or secure raceways or cables.
  
- .14 **Do not use supports or equipment installed by other trade contractors for conduit or cable support.**
  
- .15 **Do not attach conduit and cable to supports installed as part of a suspended ceiling installation (gypsum board or T-Bar for example).**
  
- .16 Install fastenings and supports as required for each type of equipment cables and conduits, and in accordance with manufacturer's installation recommendations.

### 3.6 INSTALLATION OF SPLITTER, JUNCTION, PULL BOXES AND CABINETS

- .1 Support boxes independently of connecting conduits.
- .2 Install pull boxes in inconspicuous but accessible locations. Box cover to be hinged on the side. **Do not install boxes with hinge on top.**
- .3 Install pull boxes so as not to exceed 27 m (90') of conduit run between pull boxes. Each run of raceway shall not have more than the equivalent of four 90 degree bends installed, including the bends located at an outlet or fitting.
- .4 Where construction consists of metal Q deck and steel joists (Roof deck only), conduit boxes are to be installed in such a manner that the nearest outside surface of the electrical box is not less than 38 mm (1.5") from the nearest surface of the metal roof deck.
- .5 Terminate all bonding conductors on bonding terminal strip installed inside junction box.
- .6 Use Type E cabinets where junction and or pull boxes are required to be 150 x 150 mm (6" x 6") or larger.
- .7 Use Type T cabinets when equipment is required to be housed in a lockable enclosure.
- .8 Where construction consists of metal Q deck and steel joists (Roof deck only), conduit boxes are to be installed in such a manner that the nearest outside surface of the electrical box is not less than 38 mm (1.5") from the nearest surface of the metal roof deck.
- .9 Location of junctions and/or pull boxes in suspended ceiling spaces, i.e., gypoc, T-bar, etc., are not to be greater than 760 mm (30") above finish ceiling.
- .10 All suspended types of junction and pull boxes are to be supported using a minimum of 10 mm (3/8 inch) threaded rod c/w nuts and flat washers. Secure threaded rods to boxes using one flat washer and nut installed on both sides of box. Provide as follows:
  - .1 One rod required for all types of boxes sized 150 x 150 mm (6" x 6") or smaller.
  - .2 Two rods required for all types of boxes larger than 150 x 150 mm (6" x 6") but less than 304 x 304 mm (12" x 12").
  - .3 Four rods required for all types of boxes 304 x 304 mm (12" x 12") and larger.
- .11 Where junction boxes and pull boxes are secured to building structural components, they shall be mounted and secured in such a manner so as not to be "cantilevered" (i.e, only supported on one side of the box). In rare instances where site constraints dictate the installation of a "cantilevered" box, threaded rods shall be installed to provide additional support on the opposite end.
- .12 Fill boxes with paper, sponges or foam or similar approved material to prevent entry of construction material.
- .13 Install multiple box mounting brackets and mount boxes.
- .14 For flush installations mount outlets flush with finished wall using tile rings to permit wall finish to come within 6 mm (1/4") of opening.

- .15 The front edges of boxes, cabinets and fittings installed in noncombustible walls or ceilings shall not be set in more than 6 mm (1/4").
- .16 The front edges of boxes, cabinets and fittings installed in combustible walls (ie, millwork) shall be flush with surface.
- .17 Provide correct size of openings in boxes for conduit, mineral insulated and armored cable connections. Reducing washers not to be used.

### 3.7 INSTALLATION OF CONDUITS

- .1 When installed in a group, conduits shall be parallel and evenly spaced apart.
- .2 Unless noted otherwise, conduits are to be installed as high as possible to conserve headroom, to reduce interference with other trades and cause minimum interference in spaces through which they pass.
- .3 Conceal conduits except in mechanical and electrical service rooms and in unfinished areas.
- .4 Where construction consists of metal Q deck and steel joists (Roof deck), conduits are to be installed as follows:
  - .1 In such a manner that the nearest outside surface of the conduit is not less than 38 mm (1½") from the nearest surface of the metal roof deck. Typically, this would involve the installation of conduits on the underside of top flange, secured with beam clamps or canstrut.
  - .2 Installation of conduits, raceways between the top flange of a steel support structure and a steel roof deck **is not permitted** due to the possible penetration of roof deck mechanical screws or fasteners.
  - .3 Install associated boxes in such a manner that the nearest outside surface of the box is not less than 38 mm (1½") from the nearest surface of the metal roof deck.
- .5 Where construction consists of metal Q deck and steel joists (non-roof deck), conduits are to be installed as follows:
  - .1 Between the top flange of a steel support structure and the Q-deck, where size of conduit permits.
  - .2 Where conduit sizes preclude this, install as high as possible in the space to conserve headroom.
- .6 Use rigid galvanized steel threaded conduit where subject to injury.
- .7 Use electrical metallic tubing (EMT) for the following:
  - .1 Control outlets between device box and accessible ceiling space in all walls and partitions.
  - .2 Sleeves for control wiring.
  - .3 All wiring within electrical rooms and mechanical rooms.
  - .4 All panel feeders.
  - .5 Structured wiring fibre backbone cable, where not indicated in Innerduct.
  - .6 All exposed wiring.
  - .7 Where noted elsewhere in the contract documents.

- .8 All conduit runs shall be a maximum of 30 meters (100') in length with a maximum of four (4) 90 degree bends between pull points. A pull box shall be placed in conduit runs where the sum of the bends exceeds 360 degrees, where the overall run exceeds 30 meters (100') or there is a reverse bend in the run.
- .9 Pull boxes shall be placed in straight sections of conduit run and shall not be used in lieu of a bend. Conduit fittings shall not be used in place of pull boxes or bends. The use of C, LB, LL, LR and T type fittings are prohibited.
- .10 The use of corner pulling ELLs or corner pulling elbows is not permitted.
- .11 Liquid tight metal flexible conduit is not to be used as a general purpose raceway. Use liquid tight flexible metal conduit (maximum length permitted to be 1.5 M) and liquid tight conduit fittings for:
  - .1 Final connection to vibrating equipment.
  - .2 Final connection for primary, secondary and system ground conductors on all dry core transformers.
- .12 Metal flexible conduit may be used for short runs for final connections (i.e. to security device boxes in suspended ceilings), unless noted otherwise. It must be securely fastened in place within 300 mm (12") of each junction box, cabinet and device. Install specified connectors and bushings. Where supports are required, do not derive support from ceiling support wires on supports of other trades. Do not use liquid tight metal flexible conduit in lieu of metal flexible conduit.
- .13 Bend conduit cold. Replace conduit if kinked or flattened more than 1/10th of its original diameter.
- .14 Mechanically bend steel conduit over 19 mm (3/4") diameter.
- .15 Field threads on rigid conduit must be of sufficient length to draw conduits up tight.
- .16 Install Polypropylene fish cord in empty conduits.
- .17 Where conduits become blocked, remove and replace blocked section.
- .18 Dry conduits out before installing wire.
- .19 The installation of conduits above the structure, directly below roof insulation is strictly prohibited.

### **3.8 GROUNDING AND BONDING**

- .1 Install complete permanent, continuous grounding system including, electrodes, conductors, connectors, accessories. Where EMT is used, install bonding conductor in each and every conduit.
- .2 All conduits to be complete with minimum #12 green insulated bond conductor.
- .3 Ensure all metal raceways are bonded to ground, including those used for control systems. Use a #6 green RW90 where a separate bonding conductor is run to a bonding bushing on an open end of a metal raceway.

- .4      Protect exposed grounding conductors from mechanical injury.
- .5      Use mechanical connectors for grounding connections to equipment provided with lugs.
- .6      Soldered joints not permitted.
- .7      All metal raceways shall be bonded to ground including conduits housing low voltage and control systems.
- .8      Install bonding wire for flexible conduit, connected at both ends to grounding bushing, solderless lug, clamp or cup washer and screw.
- .9      Make bonding connections in radial configuration only. Avoid loop connections.
- .10     Equipment Bonding: Install bonding connections to typical equipment included in, but not necessarily limited to following list: control transformers, control panels, etc.

### **3.9      GROUNDING BARS**

- .1      Install copper grounding busbars, mounted on insulated supports where indicated.
- .2      Bond items as indicated to ground bus, using long barrel, copper, two bolt compression connectors.
- .3      Where a pass through connector bolted to the ground busbar is required, use Burndy #KVS28.

**END OF SECTION**

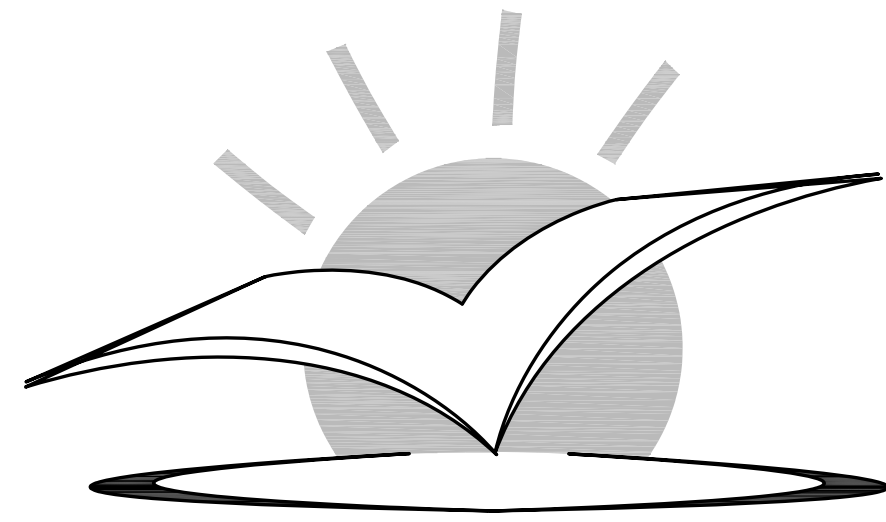

# Halifax Regional School Board

PROJECT TITLE:

## HEATING COIL

LOCATION

### BEECHVILLE LAKESIDE TIMBERLEA SCHOOL

JAMES STREET, TIMBERLEA, NOVA SCOTIA

TENDER NUMBER: 3753

DATE: 04 JUNE, 2015

**ISSUED FOR TENDER**



**FOWLER  
BAULD &  
MITCHELL**

architecture



Fowler Bauld & Mitchell Ltd.

PO Box 514, Suite 102

1660 Hollis Street, Halifax, Nova Scotia B3J 2R7

Tel: 902 429 4100 Fax: 902 423 3063

email: architects@fbm.ns.ca www.fbm.ns.ca

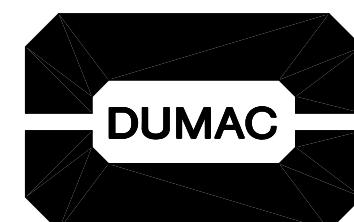

**DUMAC ENERGY LTD.**

CONSULTING ENGINEERS  
752 BEDFORD HIGHWAY  
HALIFAX, N.S.

## LIST OF DRAWINGS:

### ARCHITECTURAL

A-1 CEILING REMOVAL AND REINSTALLATION

### MECHANICAL

MH101 LEGEND AND FLOOR PLANS - HEATING  
MH401 HYDRONIC SCHEMATIC AND PARTIAL FLOOR PLANS  
MH501 HYDRONIC DETAILS AND SCHEDULES

MV101 AIR DISTRIBUTION FLOOR PLANS AND SECTIONS

MC601 CONTROLS  
MC602 CONTROLS

### ELECTRICAL

EP101 PARTIAL FLOOR PLANS, POWER, MECH CONN. ELEC. LEGEND,  
SPECIFICATIONS MOTOR STARTER AND CONTROL LIST

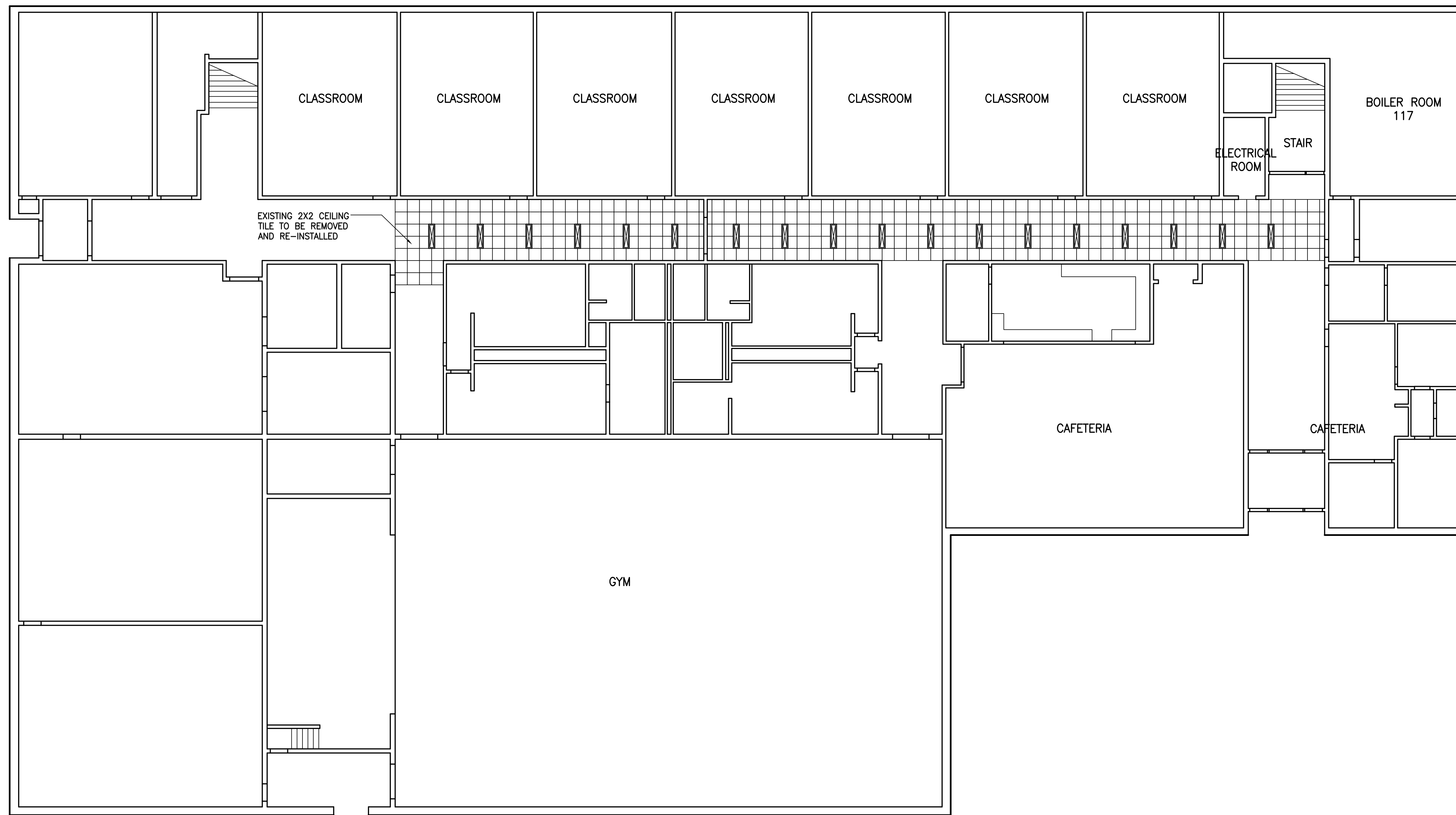

1  
A-1  
REFLECTED CEILING PLAN  
AREA OF CEILING REMOVAL & RE-INSTALLATION  
SCALE: 3/32" = 1'-0"

**GENERAL NOTES:**

1. CONTRACTOR TO MAKE GOOD ALL EXISTING SURFACES AND FINISHES AFFECTED BY THE DEMOLITION AND CONSTRUCTION AS DETAILED AND /OR IMPLIED BY THE DRAWINGS. WHERE NECESSARY TO REPAIR TO MATCH ADJACENT MATERIALS AND FINISHED, EXTEND PATCH TO NEAREST NATURAL BREAK POINT, i.e. INSIDE CORNER, EXISTING JOINT, OR LOCATION APPROVED BY ARCHITECT.
2. CONTRACTOR TO CUT, PATCH, AND MAKE GOOD EXISTING FLOORS AND WALLS AS REQUIRED BY THE WORK OF OTHER TRADES WHETHER NOTED ON THE DRAWINGS OR NOT. CONTRACTOR TO COORDINATE WITH THE MECHANICAL AND ELECTRICAL TRADES.
3. CONTRACTOR TO PROTECT AND MAINTAIN THE INTEGRITY OF EXISTING FINISHES IN AREAS NOT SCHEDULED FOR DEMOLITION WORK. ANY DAMAGE DUE TO THE DEMOLITION AND/OR NEW WORK TO BE REPAIRED AND MADE GOOD.
4. CONTRACTOR TO REPAIR ANY FIREPROOFING ON STRUCTURAL ELEMENTS AND FIRE RATED ASSEMBLIES DAMAGED DURING CONSTRUCTION.
5. CONTRACTOR TO ACOUSTICALLY SEAL ANY NEW PENETRATIONS, BOTH SIDES OF PORTIONS.
6. DO NOT ALLOW ANY ADHESIVE ODOURS AND OTHER FUMES FROM CONSTRUCTION TO ENTER THE MECHANICAL SYSTEM.
7. CONTRACTOR TO REMOVE AND LAWFULLY DISPOSE OFF SITE ALL RUBBISH AND DEBRIS RESULTING FROM CONSTRUCTION. KEEP PROJECT AREA BROOMCLEAN. WHENEVER APPLICABLE, ALL DEMOLITION DEBRIS TO BE SORTED AND TAKEN TO THE APPROPRIATE FACILITIES FOR RECYCLING.
8. CONTRACTOR TO SEAL AND REPAIR CUT-OUTS FOR MECHANICAL AND ELECTRICAL PENETRATIONS IN FLOOR, WALLS, AND CEILINGS. PROVIDE FINISHES TO MATCH EXISTING UNLESS OTHERWISE NOTED.

**CEILING NOTES:**

1. DO NOT SCALE DRAWING. LAYOUT OF CEILING AND FIXTURES IS APPROXIMATE. CONFIRM ALL DIMENSIONS ON SITE.
2. EXISTING CEILING TILE TO BE REMOVED IN AREA OF WORK AND STORED ON SITE FOR RE-INSTALLATION.
3. REMOVE AND REPLACE MAIN CARRYING TEES IN AREA OF WORK. MATCH EXISTING.
4. REMOVE EXISTING CROSS TEES AND STORE ON SITE FOR RE-INSTALLATION.
5. EXISTING LIGHT FIXTURES AND ALL ELECTRICAL DEVICES TO BE REMOVED IN AREA OF WORK AND STORED ON SITE FOR RE-INSTALLATION BY THE ELECTRICAL CONTRACTOR.
6. NO CEILING WORK REQUIRED WHERE CEILING SHOWN BLANK.

KEY PLAN

LOGO



Fowler Bauld & Mitchell Ltd.  
PO Box 514, Suite 102  
1660 Hollis Street  
Halifax, Nova Scotia B3J 2R7  
Tel: 902 429 4100  
Fax: 902 423 3063  
architects@fblm.ns.ca  
www.fblm.ns.ca

GRAPHIC SCALE

04 JUN 15	ISSUED FOR TENDER
DATE	ISSUE

STAMP

SCALE 3/32" = 1'-0"

DRAWN BY: MDG

CHECKED BY: GAC

REVIEWED BY:

APPROVED BY:

AS-BUILT CHECK

DATE: 04 JUN 2015

PROJECT

BEECHVILLE LAKESIDE  
TIMBERLEA SCHOOL  
HEATING COIL

JAMES ST., TIMBERLEA, NS

PROJECT NO.: 2015-058

SHEET TITLE

CEILING REMOVAL  
AND REINSTALLATION

INTERNAL NO.: HRSB #3753



# HYDRONIC SYSTEMS

- HWS — HOT WATER HEATING SUPPLY
- HWR — HOT WATER HEATING RETURN
- GWS — GLYCOL HEATING SUPPLY
- GWR — GLYCOL HEATING RETURN
- EHWS — EXISTING HOT WATER SUPPLY
- EHWR — EXISTING HOT WATER RETURN
- ××× EHWS ××× REMOVE EXISTING HOT WATER SUPPLY
- ××× EHWR ××× REMOVE EXISTING HOT WATER RETURN
- ELBOW TURNED UP
- ◊ ELBOW TURNED DOWN
- UNION —
- TW — TEMPERATURE SENSING BULB WELL WITH THERMOMETER
- PG — PRESSURE GAUGE WITH GAUGE COCK
- >— DIRECTION OF FLOW
- V — VALVE (SEE SPEC FOR TYPE)
- C — CHECK VALVE
- R — RELIEF VALVE PIPED TO DRAIN
- H — HOSE END DRAIN VALVE
- B — CIRCUIT BALANCING VALVE
- PG — PIPE GUIDE
- C.T.E. — CONNECT TO EXISTING, EXACT LOCATION TO BE DETERMINED ON SITE

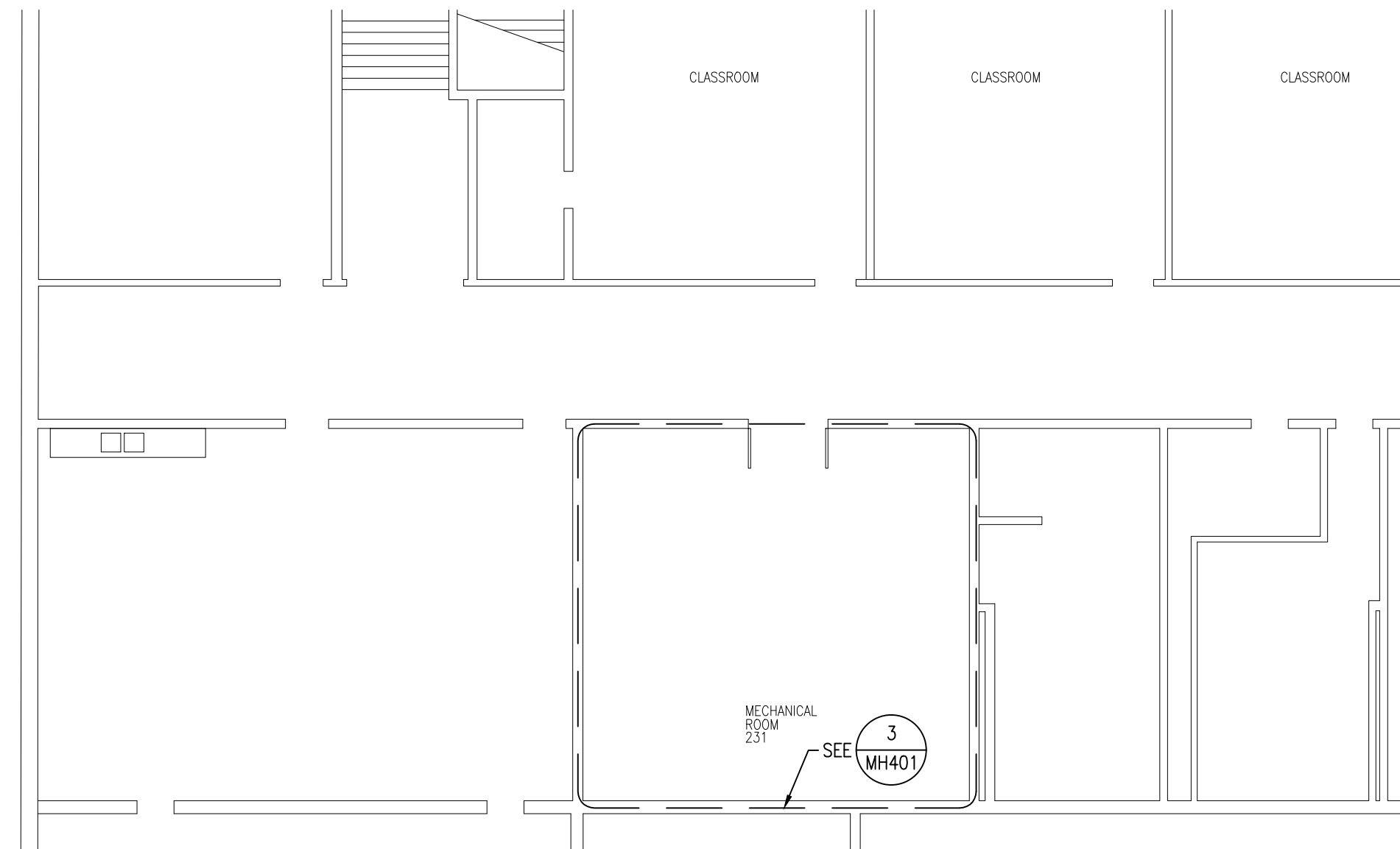

**2** PARTIAL SECOND FLOOR PLAN-HYDRONIC  
MH101 3/32" = 1' 0"

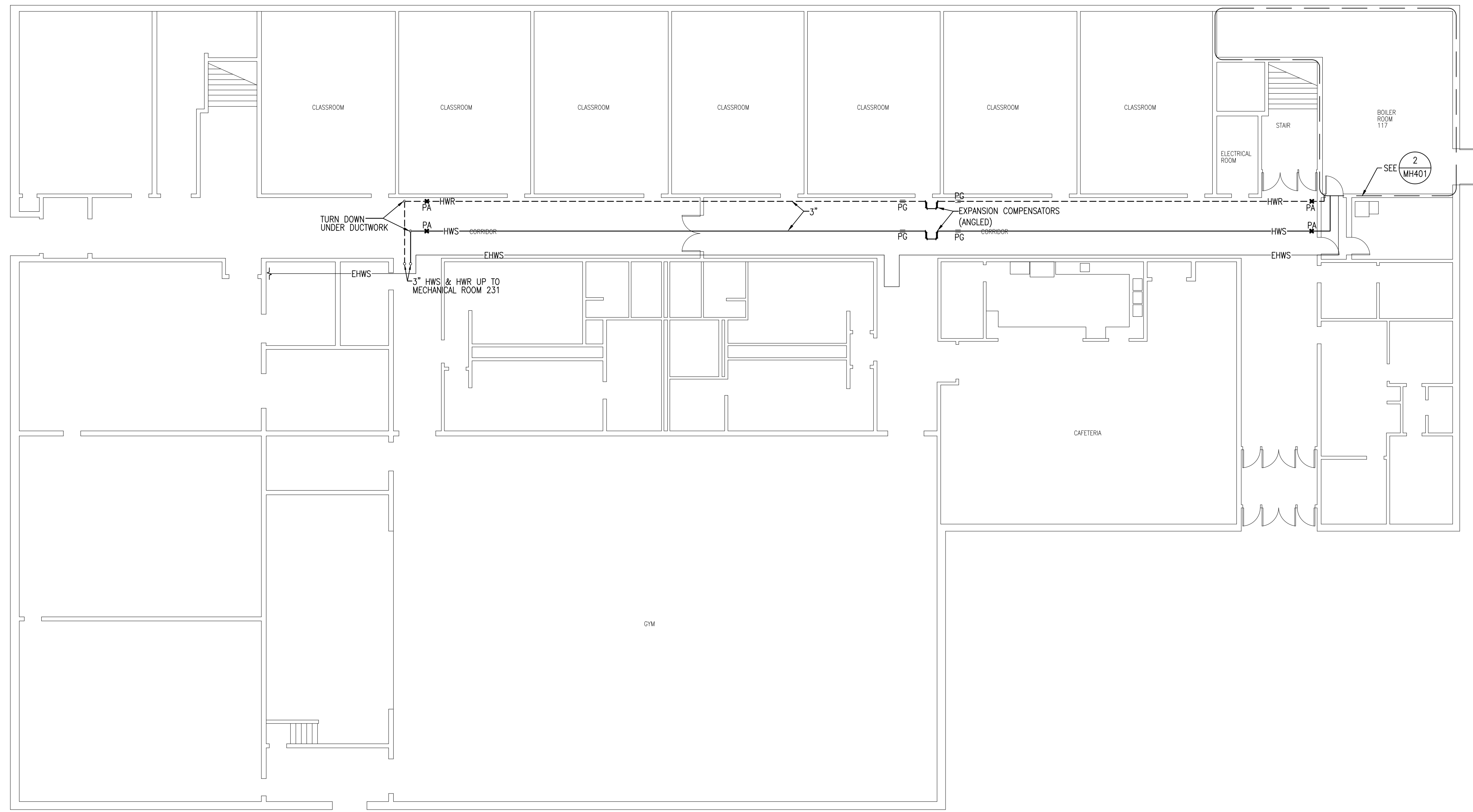

**1** MAIN FLOOR PLAN-HYDRONIC  
MH101 3/32" = 1' 0"

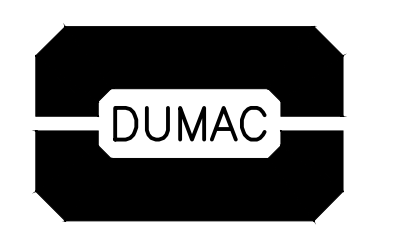

**DUMAC ENERGY LTD.**  
CONSULTING ENGINEERS  
752 BEDFORD HIGHWAY  
HALIFAX, N.S.  
Tel: (902) 457-1300  
Fax: (902) 457-1777  
Email: DUMAC@DUMACNS.CA

GRAPHIC SCALE

04 JUN 15 1 ISSUED FOR TENDER  
DATE MARK ISSUE



SCALE 3/32" = 1' 0"  
DRAWN BY: STAFF  
CHECKED BY: MGD  
REVIEWED BY: MGD  
APPROVED BY: MGD  
AS-BUILT CHECK  
DATE: MAY 2015

PROJECT  
BEECHVILLE LAKESIDE  
TIMBERLEA SCHOOL  
HEATING COIL

JAMES STREET, TIMBERLEA, NS

PROJECT NO.:

SHEET TITLE  
LEGEND AND  
FLOOR PLANS  
HEATING

INTERNAL NO.: HRSB #3753

**MH101**

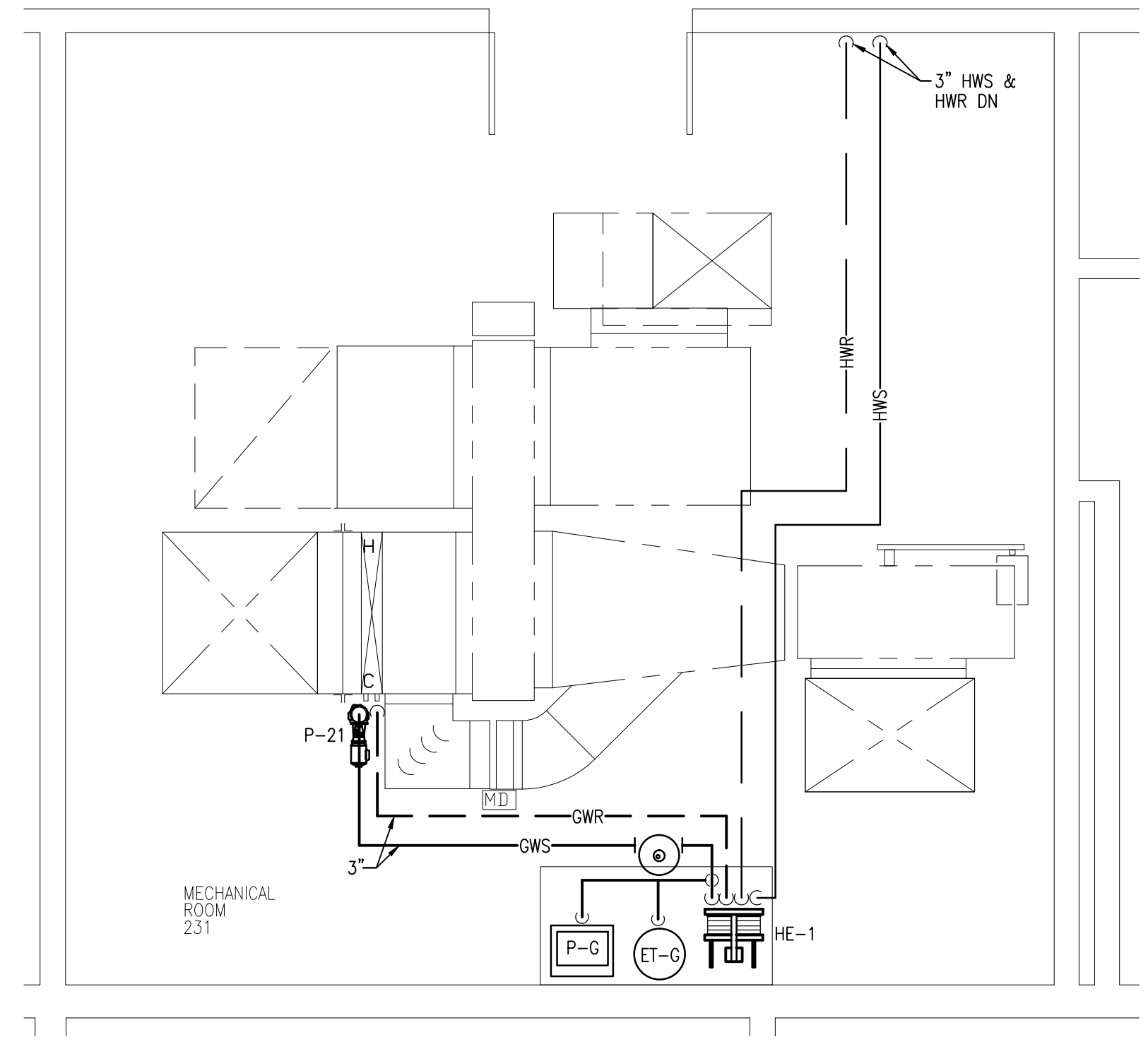

3 MECHANICAL ROOM 231 PIPING PLAN  
MH401 1/4" = 1' 0"

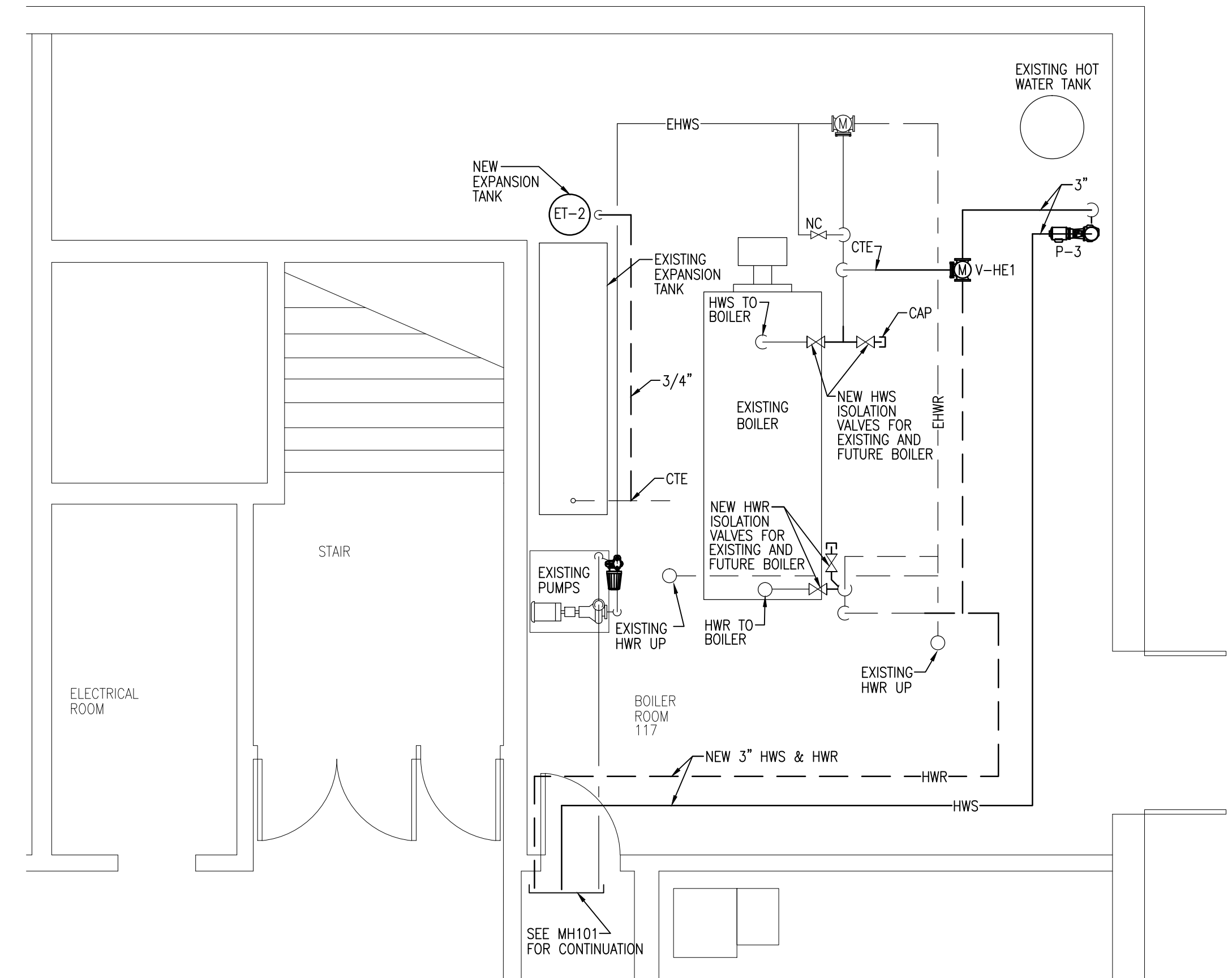

2 BOILER ROOM 117 PIPING PLAN  
MH401 1/4" = 1' 0"

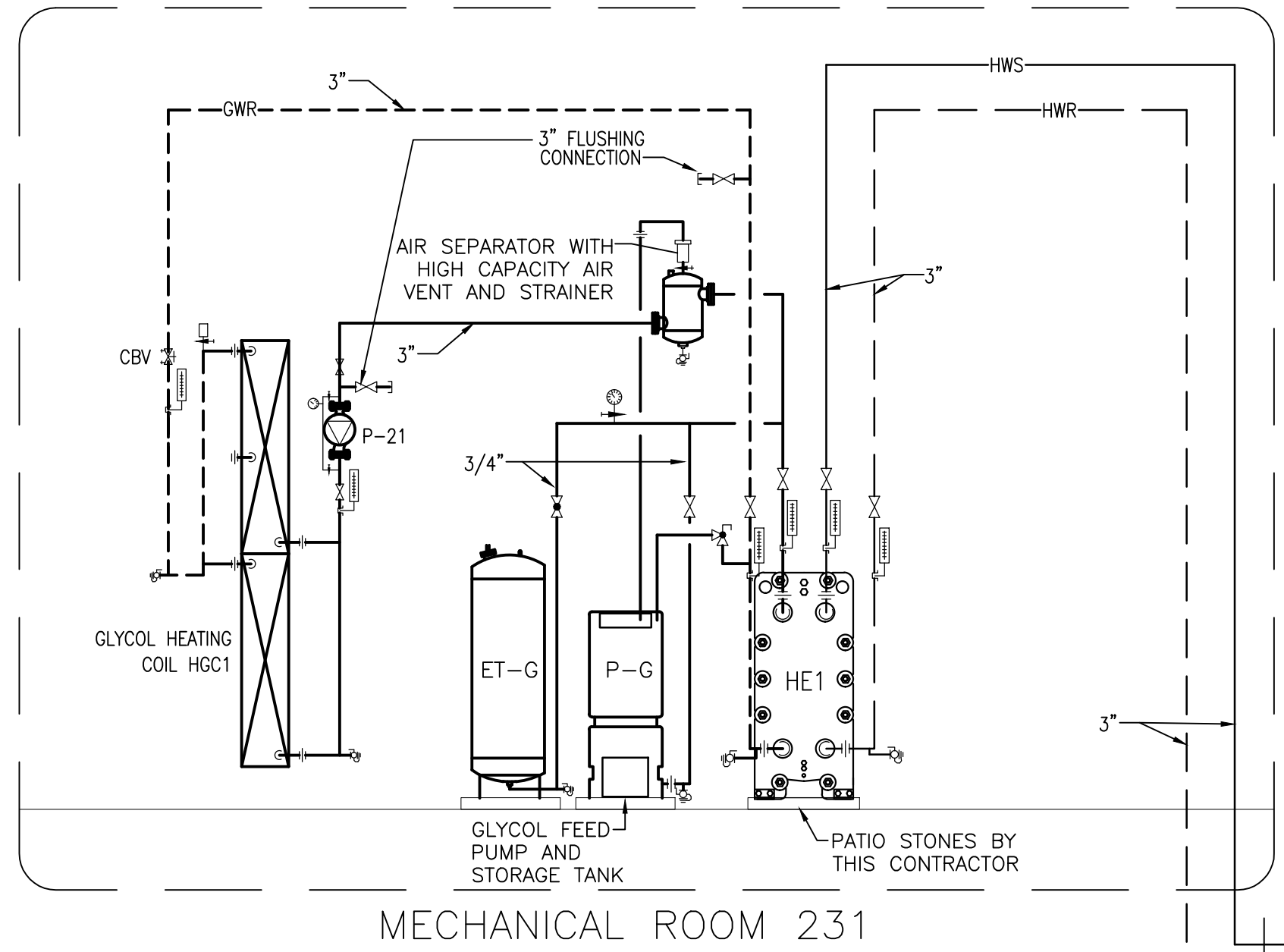

MECHANICAL ROOM 231

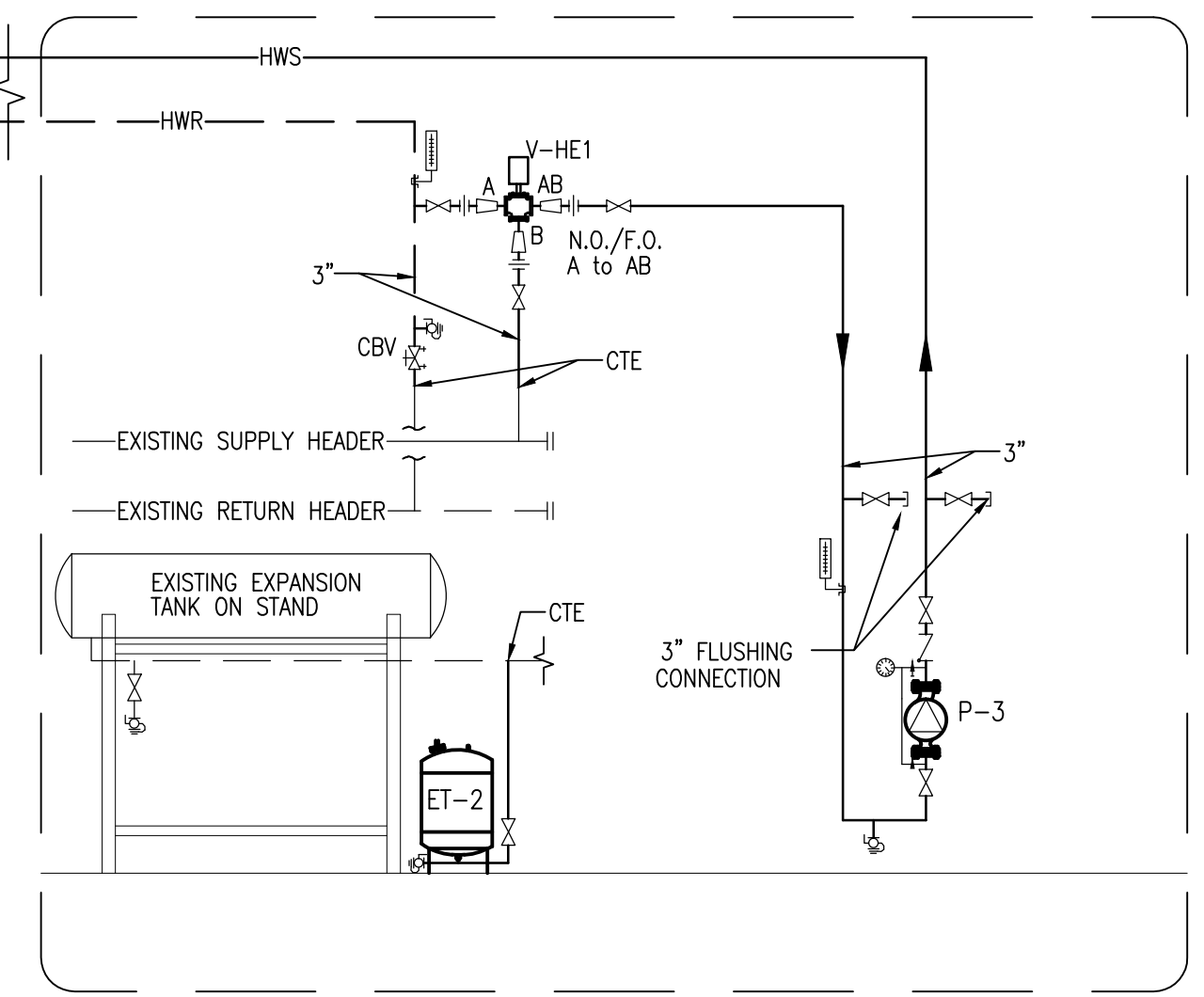

BOILER ROOM 117

1 HYDRONIC PIPING SCHEMATIC  
MH401 NTS

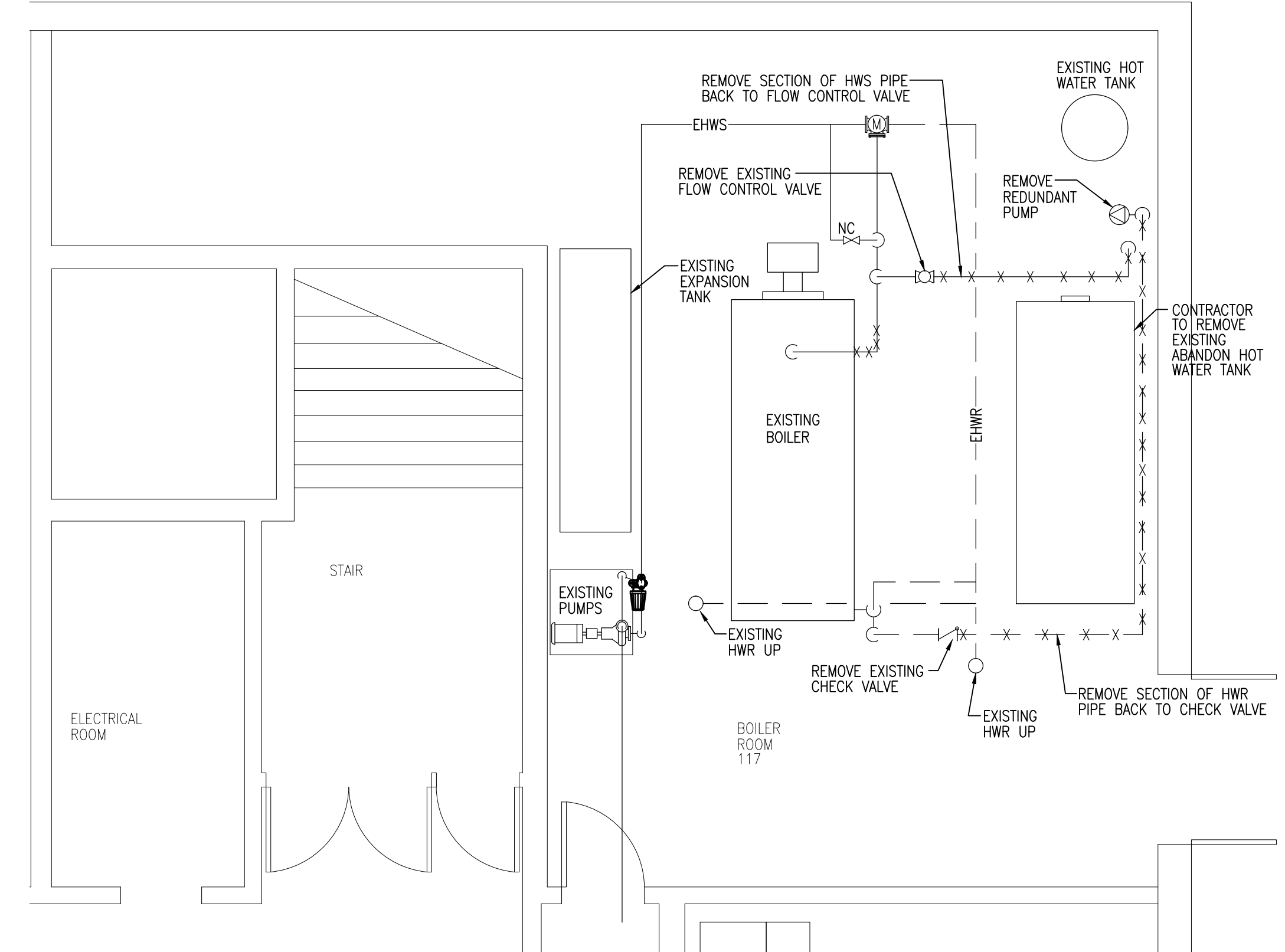

4 BOILER ROOM 117 DEMO PLAN  
MH401 1/4" = 1' 0"

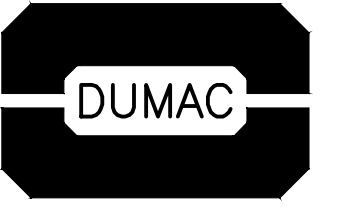

DUMAC ENERGY LTD.  
CONSULTING ENGINEERS  
752 BEDFORD HIGHWAY  
HALIFAX, N.S.  
Tel: (902) 457-1300  
Fax: (902) 457-1777  
Email: DUMAC@DUMACNS.CA

GRAPHIC SCALE

04 JUN 15 1 ISSUED FOR TENDER  
DATE MARK ISSUE

STAMP



SCALE AS NOTED  
DRAWN BY: STAFF  
CHECKED BY: MGD  
REVIEWED BY: MGD  
APPROVED BY: MGD  
AS-BUILT CHECK  
DATE: MAY 2015

PROJECT  
BEECHVILLE LAKESIDE  
TIMBERLEA SCHOOL  
HEATING COIL

JAMES STREET, TIMBERLEA, NS

PROJECT NO.:

SHEET TITLE

HYDRONIC  
SCHEMATIC AND  
PARTIAL FLOOR  
PLANS

INTERNAL NO.: HRSB #3753

MH401

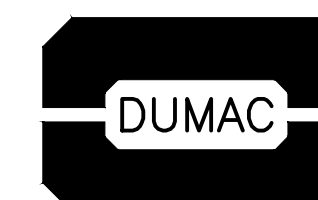

DUMAC ENERGY LTD.  
CONSULTING ENGINEERS  
752 BEDFORD HIGHWAY  
HALIFAX, N.S.  
Tel: (902) 457-1300  
Fax: (902) 457-1777  
Email: DUMAC@DUMACNS.CA

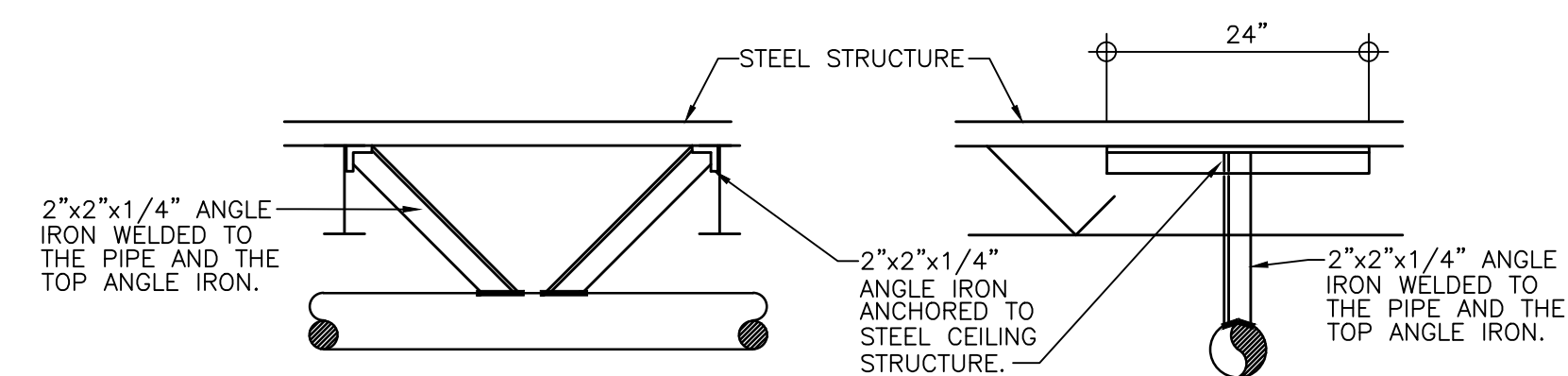

1 PIPE ANCHOR DETAIL  
MH501 NTS

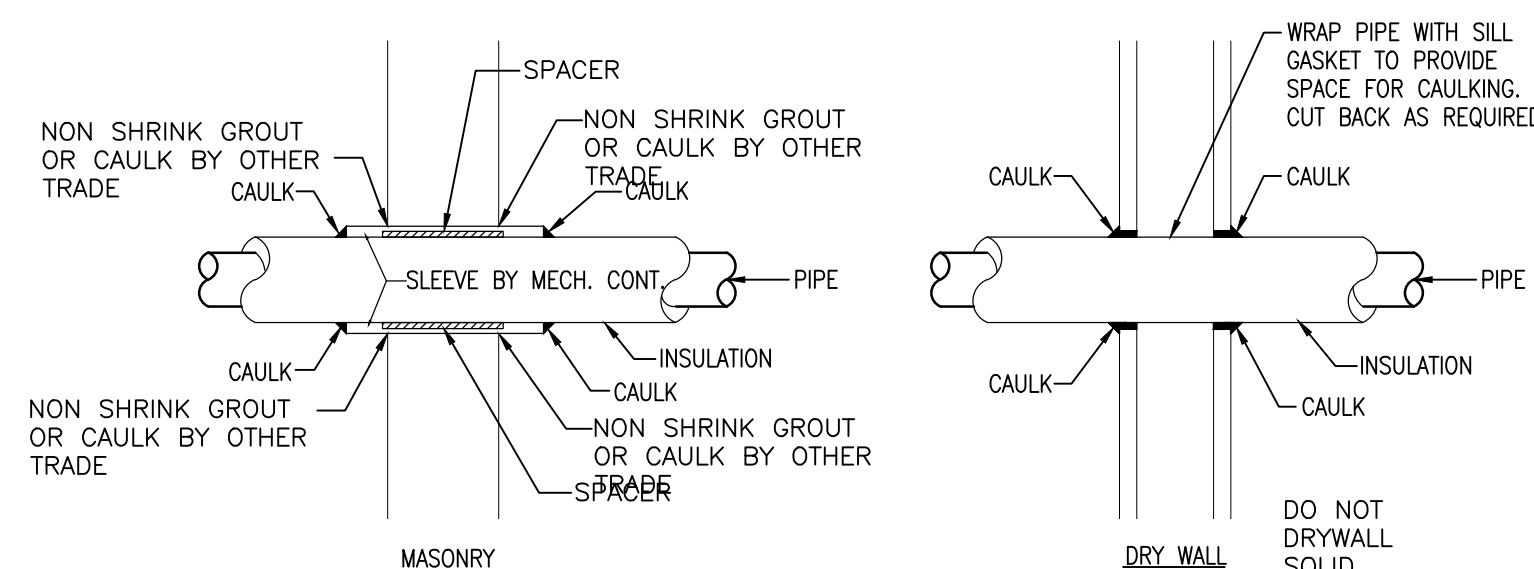

2 INSULATED PIPE THRU UNRATED PARTITION  
MH501 NTS

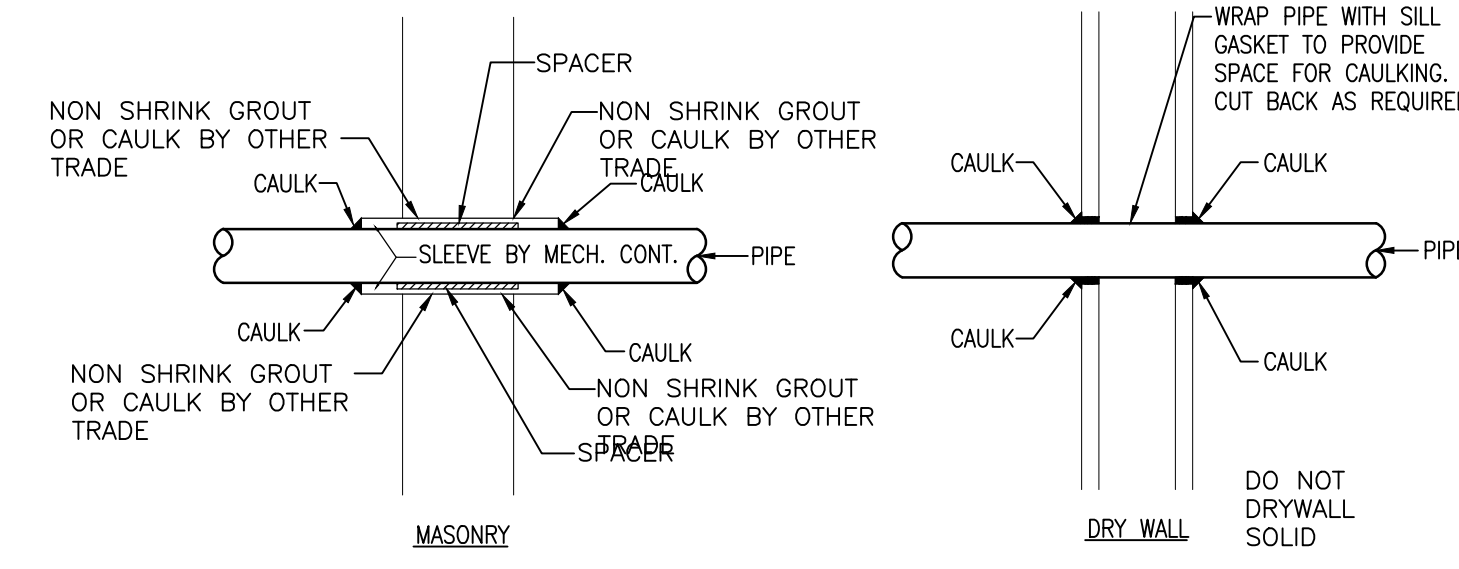

3 UNINSULATED PIPE THRU UNRATED PARTITION  
MH501 NTS

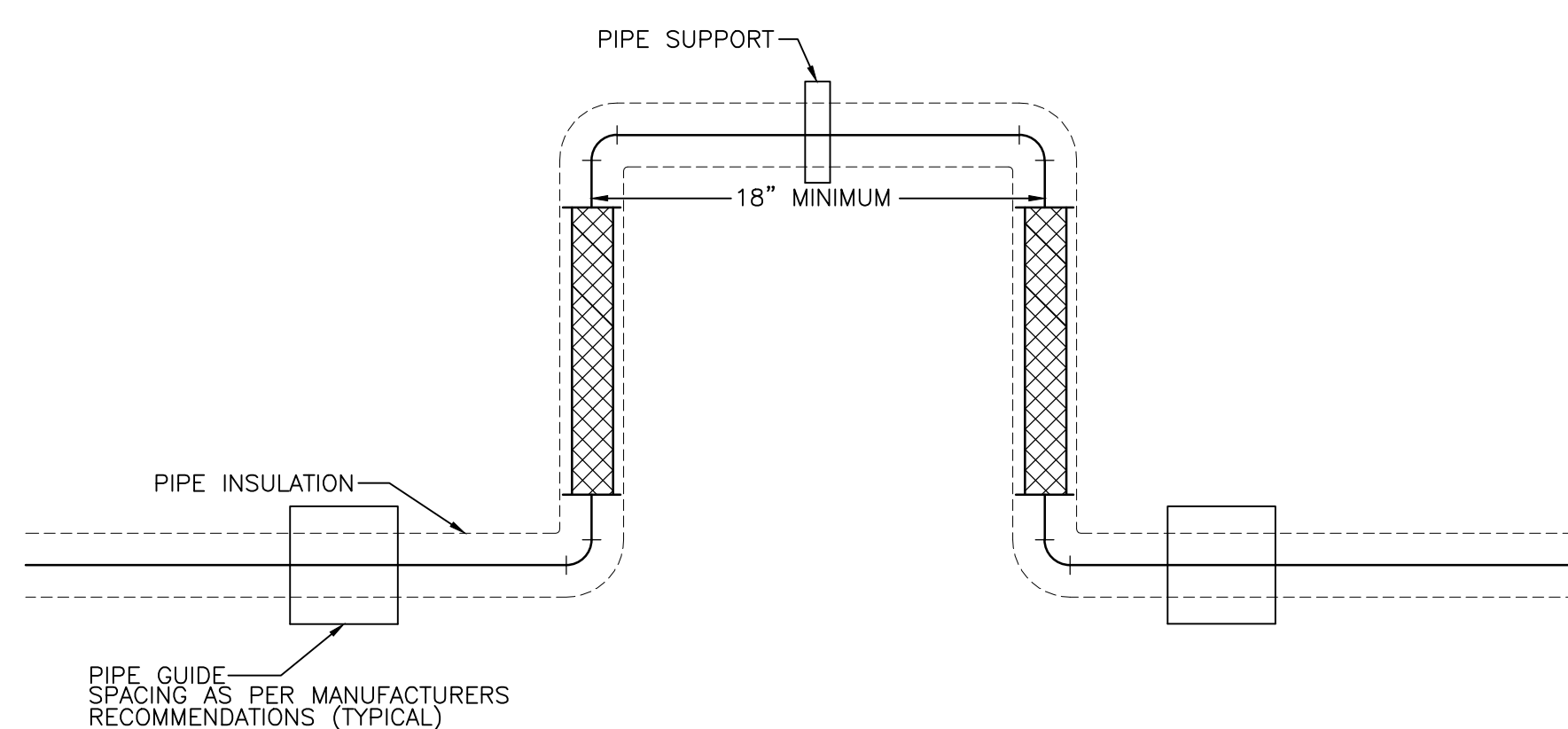

4 FLEXIBLE HOSE EXPANSION LOOP  
MH501 N.T.S.



5 TYPICAL PIPE IDENTIFICATION  
MH501 NTS

GRAPHIC SCALE

04 JUN 15 11 ISSUED FOR TENDER  
DATE MARK ISSUE

STAMP

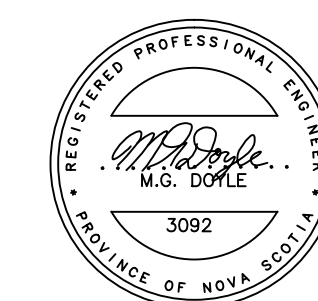

SCALE AS NOTED

DRAWN BY: STAFF

CHECKED BY: MGD

REVIEWED BY: MGD

APPROVED BY: MGD

AS-BUILT CHECK

DATE: MAY 2015

PROJECT  
BEECHVILLE LAKESIDE  
TIMBERLEA SCHOOL  
HEATING COIL

JAMES STREET, TIMBERLEA, NS

PROJECT NO.:

SHEET TITLE

HYDRONIC DETAILS  
AND SCHEDULES

INTERNAL NO.: HRSB #3753

MH501

HEATING COIL SCHEDULE																
SYSTEM	SYMBOL	STANDARD OF ACCEPTANCE		AIRFLOW	EXISTING MOTOR			HEATING COIL 40% PROPYLENE GLYCOL						ACCESSORIES AND/OR REMARKS		
		MANUFACTURER	MODEL#		CFM @ °WG	DRIVE	HP	VOLTAGE	MAX. VEL	EAT ° F	LAT ° F	EWT ° F	LWT ° F			
AH-1	HGC-1A&B	DAIKIN-MCQUAY	2@ 5MH0702B	18800	BELT	10	208/3	671	28	70	160	140	98	5.6	0.24	

PUMP SCHEDULE										
SYMBOL	SERVICE	LOCATION	STANDARD OF ACCEPTANCE		FLUID	FLOW at P.D. GPM at FT.HD	MOTOR			REMARKS
			MANUFACTURER	MODEL			RPM	WATTS	VOLTAGE	
P-3	HE-1 HOT SIDE	BOILER ROOM 117	GRUNDFOS	UPS 50-160FB	WATER	93 @ 30	-	1300	208/3ø	
P-21	AH-1 HEATING COIL	MECHANICAL ROOM 231	GRUNDFOS	UPS 50-160FB	40% GLYCOL	98 @ 22	-	1300	208/3ø	
P-G	GLYCOL FILL STATION	MECHANICAL ROOM 231	AXIOM	SF100	40% GLYCOL	-	-	-	120/1ø	

HEAT EXCHANGER SCHEDULE														
SYMBOL	SERVICE	LOCATION	STANDARD OF ACCEPTANCE		WARM SIDE			COLD SIDE			BTU LOAD	ACCESSORIES AND/OR REMARKS		
			MANUFACTURER	MODEL	FLUID	FLOW GPM@FTHD	EWTF	LWTF	FLUID	FLOW GPM @ FTHD				EWTC
HE-1	GLYCOL SYSTEM	MECHANICAL ROOM 231	BELL & GOSSETT	P14	BOILER WATER	93 @ 30	180	160	40% PROP. GLYCOL	98 @ 22	140	160	906478	15% EXCESS SURFACE AREA

EXPANSION TANK SCHEDULE						
SYMBOL	SERVICE	LOCATION	STANDARD OF ACCEPTANCE		TOTAL VOL. GALLONS	ACCESSORIES AND/OR REMARKS
			MANUFACTURER	MODEL		
ET-2	HEATING SYSTEM	BOILER ROOM 117	EXPANFLEX	AL-85	23.0	-
ET-G	GLYCOL SYSTEM	MECHANICAL ROOM 231	EXPANFLEX	AL-85	23.0	SUITABLE FOR GLYCOL SERVICE

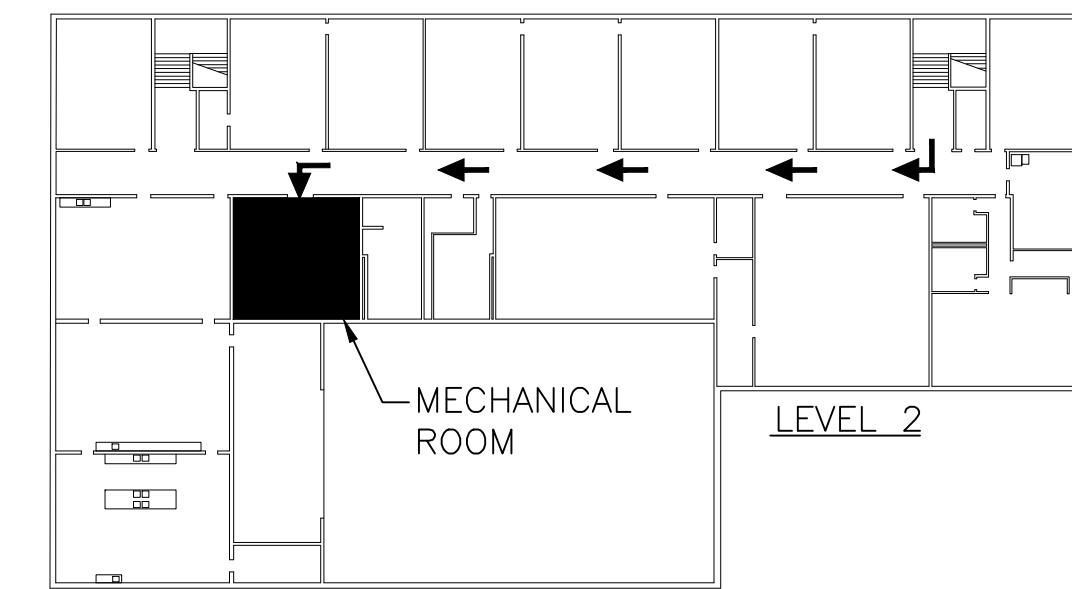

KEY PLAN

LEGEND: AIR DISTRIBUTION

- EXISTING DUCTWORK TO REMAIN.
- EXISTING DUCTWORK TO BE REMOVED.
- NEW DUCTWORK AND/OR EQUIPMENT.
- NEW SQUARE DUCT ELBOW c/w TURNING VAINS.
- CTE CONNECT TO EXISTING
- ① REFER TO NOTE 1.

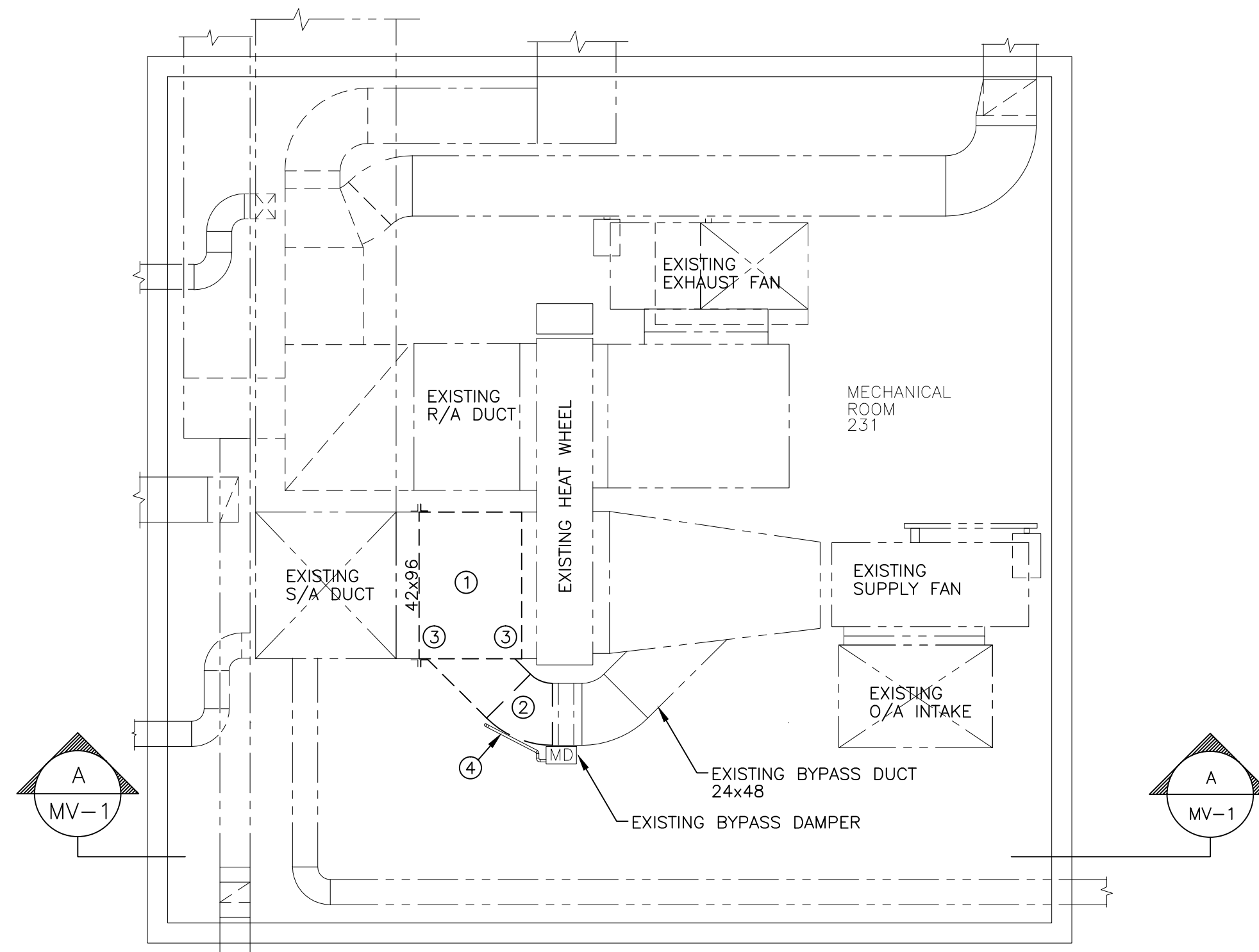

1 PARTIAL LEVEL 2 FLOOR PLAN - MECHANICAL RM.  
MV101 AIR DISTRIBUTION REMOVALS  
1/4"=1'-0"

- NOTES: AIR DISTRIBUTION REMOVALS
- ① REMOVE EXISTING TRANSITION DUCT FROM FLANGED CONNECTION BACK TO FLEX CONNECTION AT EXISTING HEAT WHEEL.
  - ② REMOVE EXISTING 24x48 BYPASS DUCT FROM TRANSITION BACK TO EXISTING BYPASS DAMPER AS INDICATED.
  - ③ SEE REVISED AIR DISTRIBUTION DRAWING THIS SHEET FOR NEW CONNECTIONS TO EXISTING DUCTWORK AND HEAT WHEEL.
  - ④ MAINTAIN EXISTING CONTROLS FOR EXISTING MOTORIZED DAMPER

PRIOR TO DUCT MODIFICATIONS MEASURE SUPPLY AIRFLOW AND PROVIDE WRITTEN REPORT TO CONSULTANT

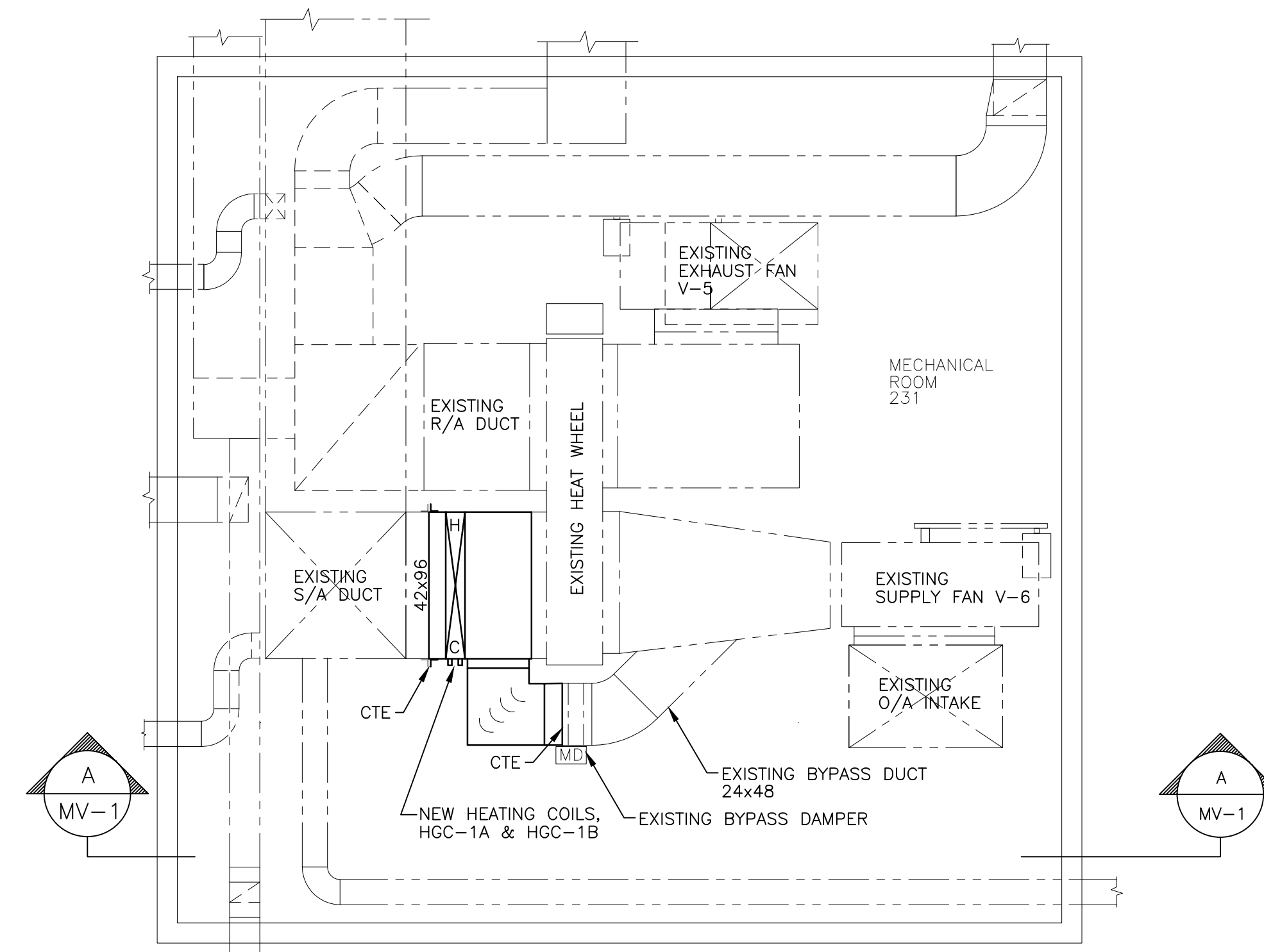

3 PARTIAL LEVEL 2 FLOOR PLAN - MECHANICAL RM.  
MV101 REVISED AIR DISTRIBUTION  
1/4"=1'-0"

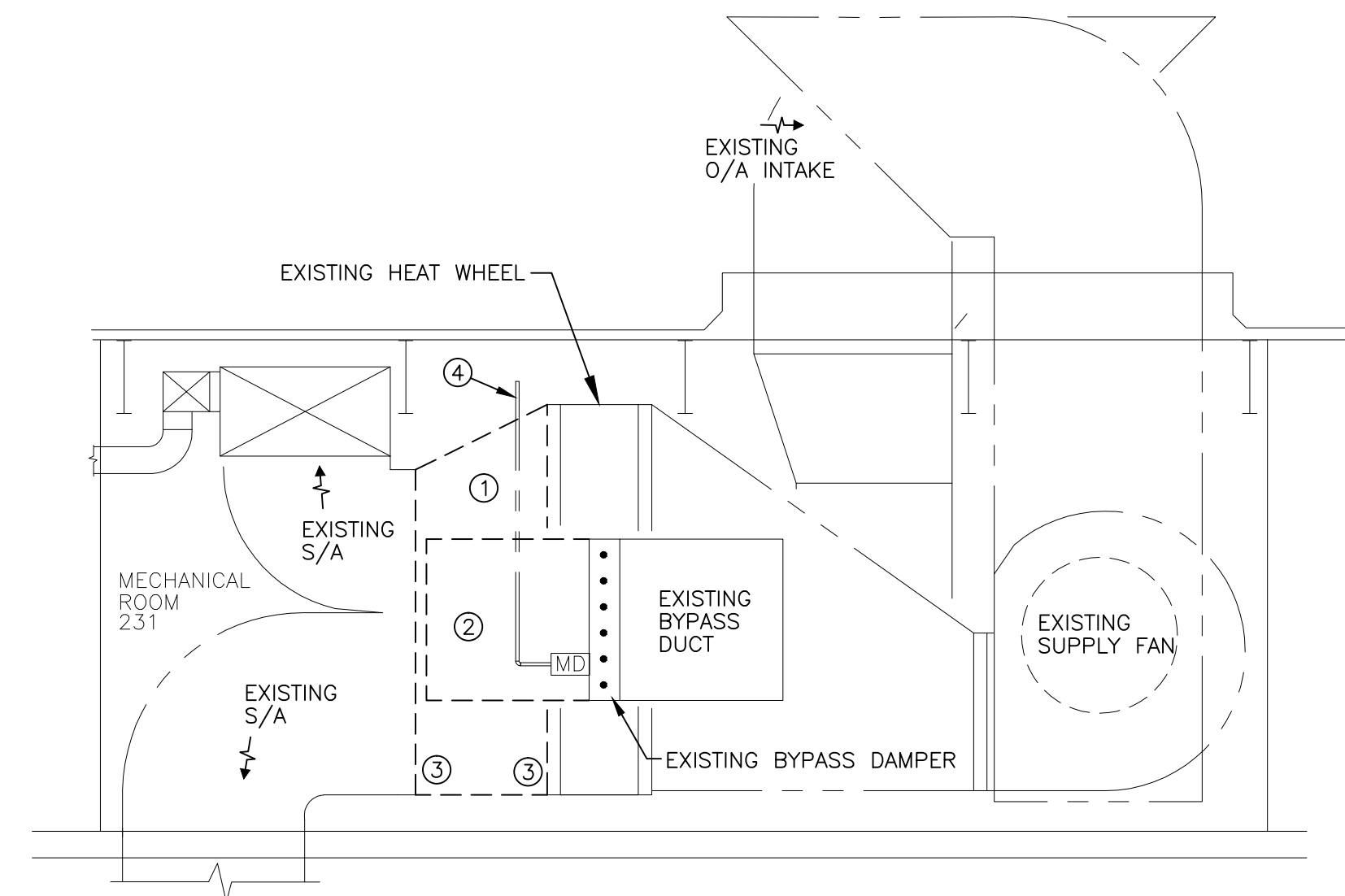

2 SECTION "A" -  
MV101 AIR DISTRIBUTION REMOVALS  
1/4"=1'-0"

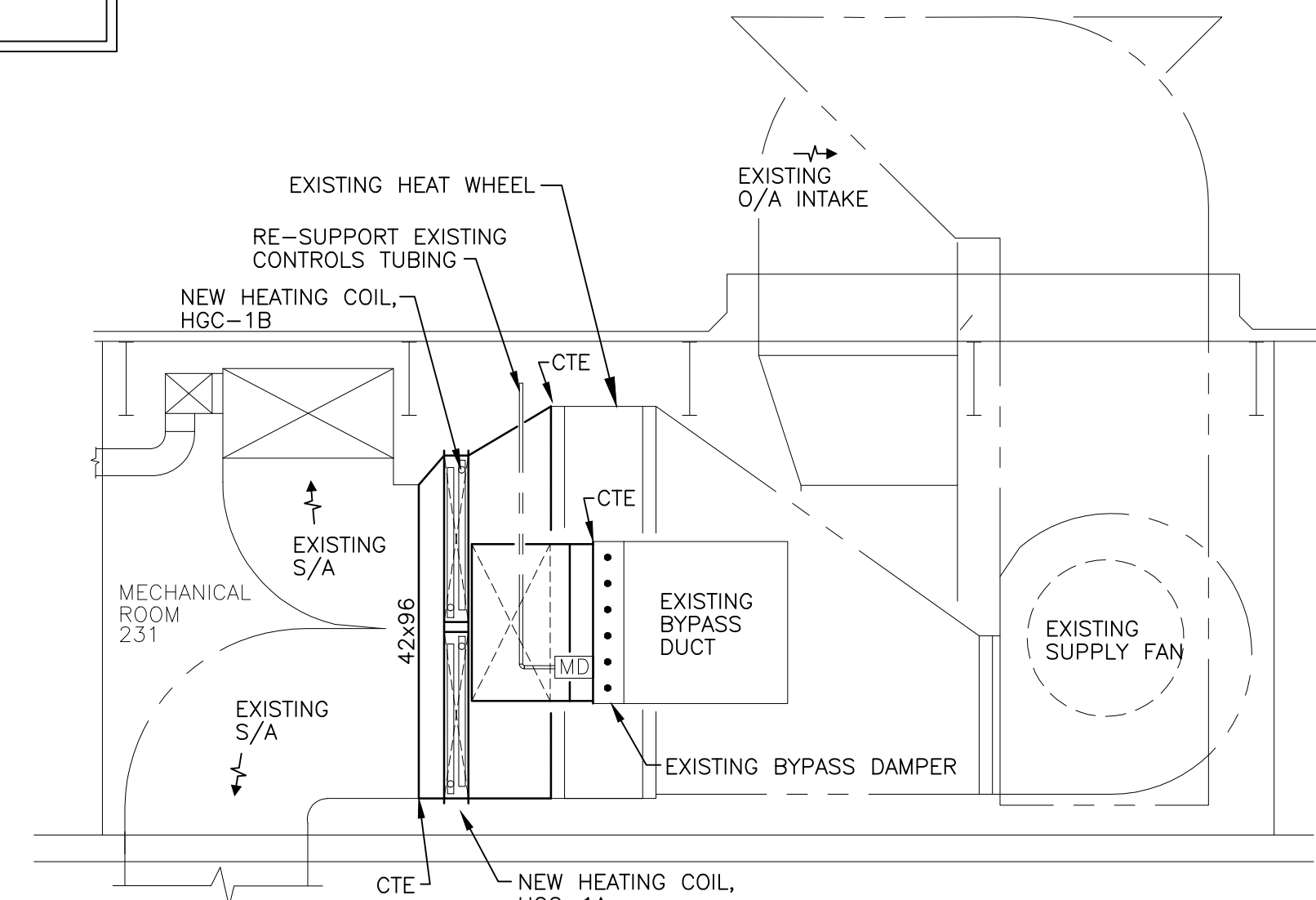

4 SECTION "A" -  
MV101 REVISED AIR DISTRIBUTION  
1/4"=1'-0"

GRAPHIC SCALE

04 JUN 15 11 ISSUED FOR TENDER  
DATE MARK ISSUE

STAMP

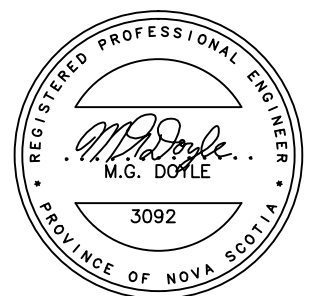

SCALE AS NOTED  
DRAWN BY: STAFF  
CHECKED BY: MGD  
REVIEWED BY: MGD  
APPROVED BY: MGD  
AS-BUILT CHECK  
DATE: MAY 2015

PROJECT  
BEECHVILLE LAKESIDE  
TIMBERLEA SCHOOL  
HEATING COIL

JAMES STREET, TIMBERLEA, NS

PROJECT NO.:

SHEET TITLE

AIR DISTRIBUTION  
FLOOR PLANS  
AND SECTIONS

INTERNAL NO.: HRSB #3753

MV101

### CONTROLS

AO	ANALOG OUTPUT
AI	ANALOG INPUT
BO	BINARY OUTPUT
BI	BINARY INPUT
----- WIRING BY ELECTRICAL CONTRACTOR	
- - - - - WIRING BY CONTROLS CONTRACTOR	
O.A.	OUTSIDE AIR
R.A.	RETURN AIR
S.A.	SUPPLY AIR
E.A.	EXHAUST AIR

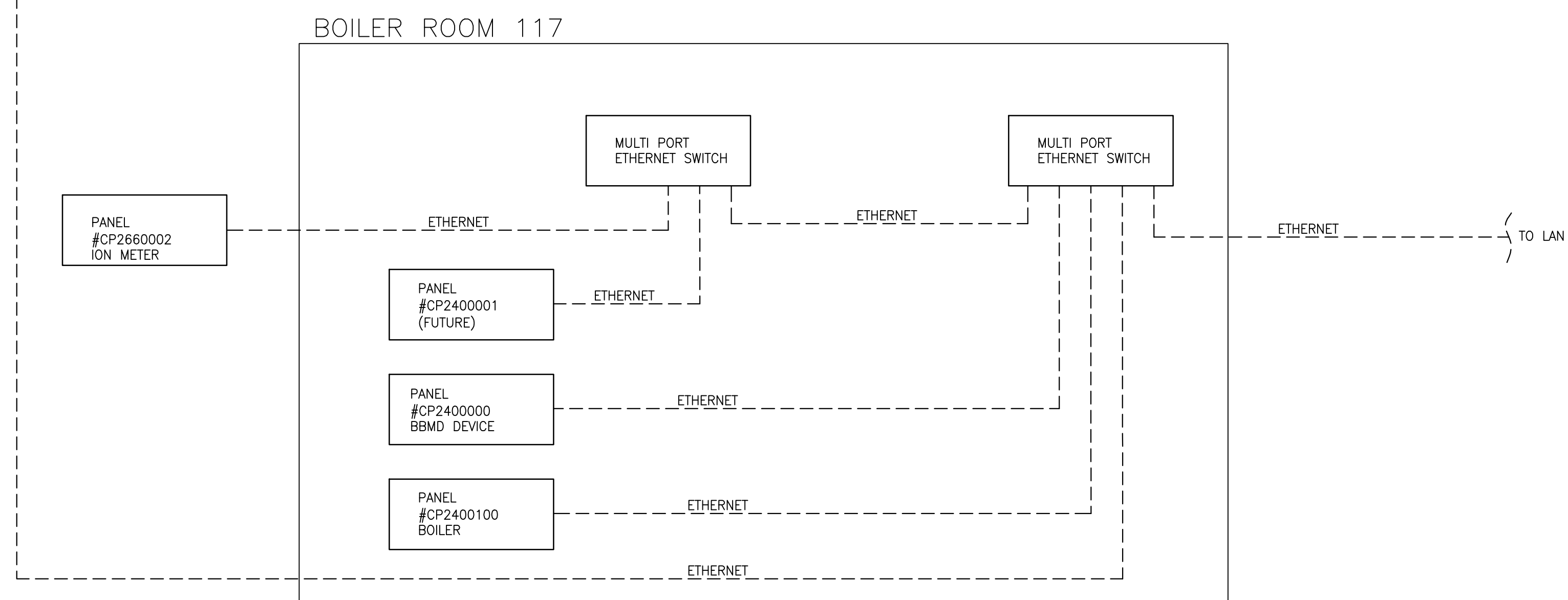
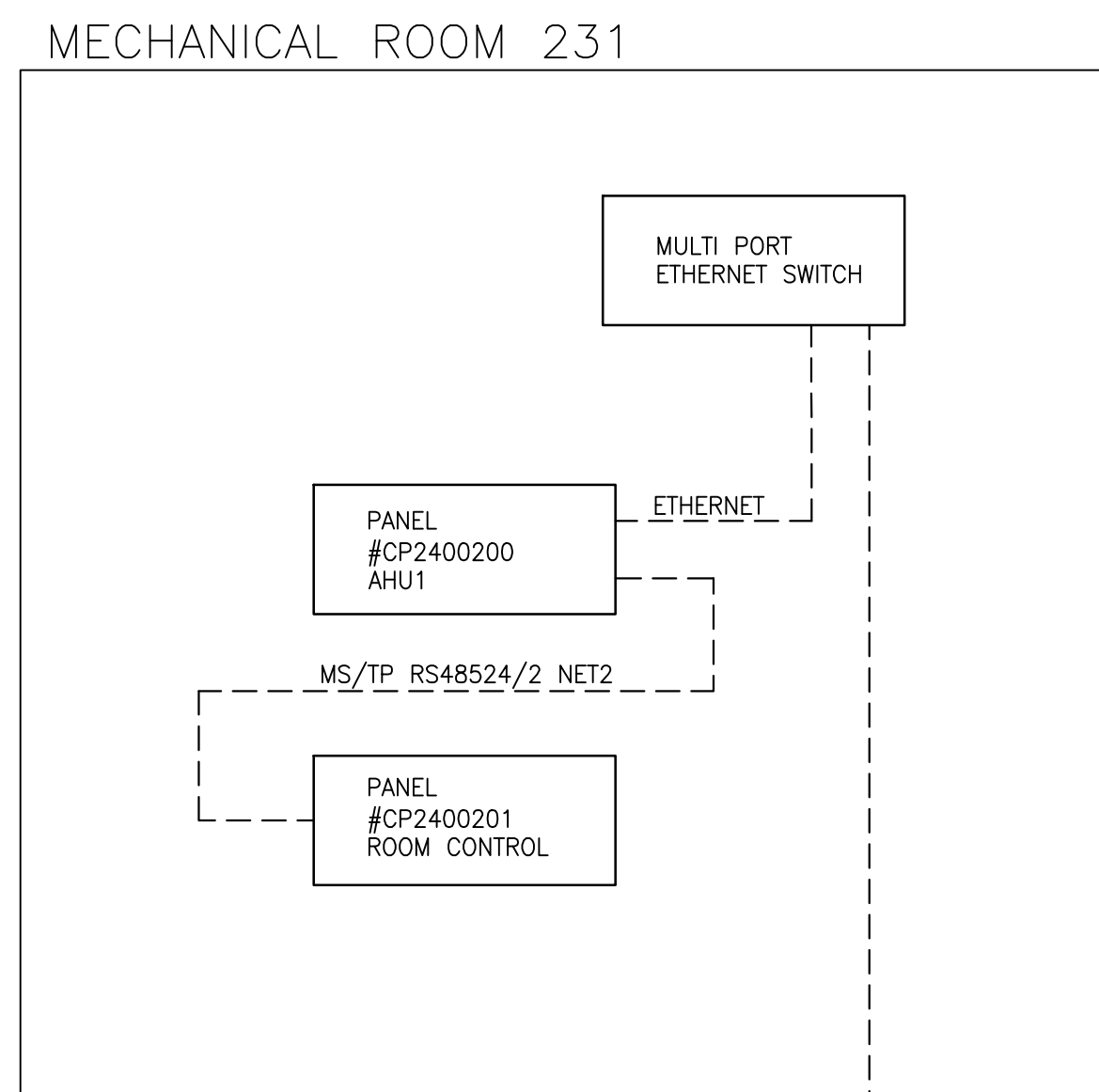

1 EXISTING BAS ARCHITECTURE  
MC601

OWNER WILL SUPPLY ADDITIONAL DELTA DSC1616E CONTROLLERS AND CONTROLLER CABINETS. CONTROL CONTRACTOR TO INSTALL AND PROGRAM

----- WIRING BY ELECTRICAL CONTRACTOR  
- - - - - WIRING BY CONTROLS CONTRACTOR

#### NOTES

- REFER TO DRAWING E9101 FOR MOTOR STARTER AND CONTROL LIST.
- WHERE NOTED, CURRENT SENSOR AND RELAY 'RC' PROVIDED BY ELECTRICAL CONTRACTOR, REFER TO ELECTRICAL SPECIFICATION.
- CONTROLS CONTRACTOR TO CONTROL RELAY 'RC'. PROVIDE ADAPTORS AS REQUIRED.
- CONTROLS CONTRACTOR TO READ CURRENT SENSOR. PROVIDE ADAPTORS AS REQUIRED.

GRAPHIC SCALE

04 JUN 15 1 ISSUED FOR TENDER  
DATE MARK ISSUE

STAMP

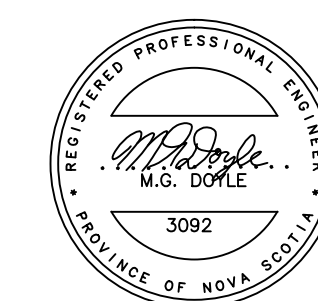

SCALE AS NOTED

DRAWN BY: STAFF

CHECKED BY: MGD

REVIEWED BY: MGD

APPROVED BY: MGD

AS-BUILT CHECK

DATE: MAY 2015

PROJECT  
BEECHVILLE LAKESIDE  
TIMBERLEA SCHOOL  
HEATING COIL

JAMES STREET, TIMBERLEA, NS

PROJECT NO.:

SHEET TITLE

CONTROLS

INTERNAL NO.: HRSB #3753

MC601

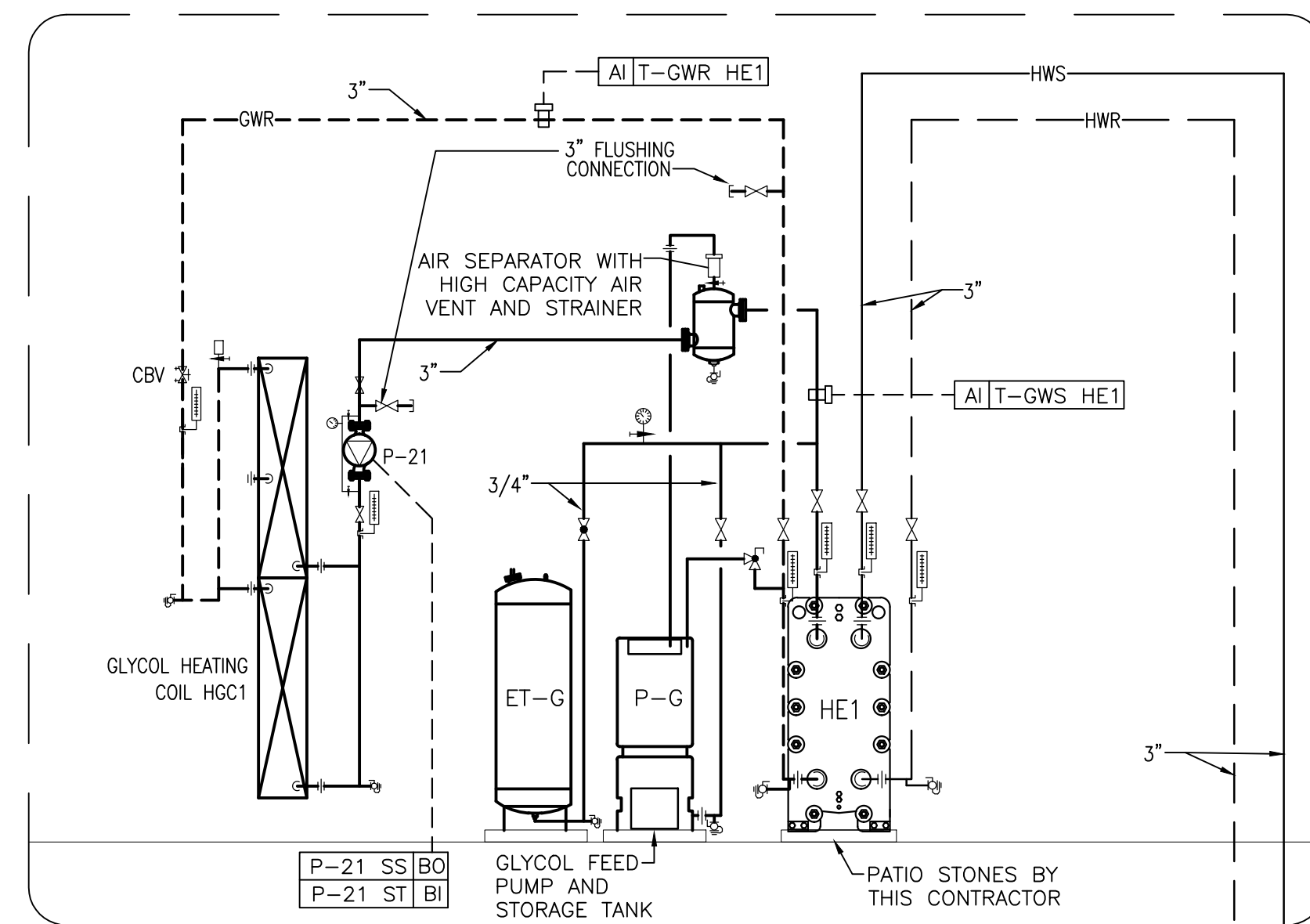

MECHANICAL ROOM 231

**GLYCOL HEAT EXCHANGER**

IF OUTSIDE AIR TEMPERATURE (OAT) IS ABOVE 14° C, GLYCOL HEAT EXCHANGER PUMPS ARE DE-ENERGIZED

IF OAT IS BETWEEN 6° C AND 12° C, A GLYCOL HEAT EXCHANGER PUMP ON EACH SIDE OF THE HEAT EXCHANGER OPERATES WHEN ANY AIR SYSTEM IS ON AND THERE IS A CALL FOR HEAT AT AN AIR HANDLING UNIT.

GLYCOL HEAT EXCHANGER PUMPS TO START 1 HOUR BEFORE AIR HANDLING UNITS ARE SCHEDULED ON AND STOP WHEN AIR HANDLING UNITS STOP.

IF NO CALL FOR HEAT AT AN AIR HANDLING UNIT FOR 30 MINUTES, TURN OFF GLYCOL PUMP SYSTEM.

IF CALL FOR HEAT AT THE AIR HANDLING UNIT FOR 15 MINUTES OR SAT IS 3° C BELOW SETPOINT WHEN PUMPS ARE OFF, TURN GLYCOL PUMP SYSTEM BACK ON.

IF OAT IS BELOW 5° C, A GLYCOL HEAT EXCHANGER PUMP ON EACH SIDE OF THE HEAT EXCHANGER OPERATES CONTINUOUSLY.

THE BAS MODULATES GLYCOL SUPPLY TEMPERATURE IN ACCORDANCE WITH THE FOLLOWING SCHEDULE:

OAT -18° C T-GWS 55° C MAX  
OAT +14° C T-GWS 35° C MIN

GLYCOL TEMPERATURE IS RESET DOWN IF ALL AIR SYSTEMS ARE NOT CALLING FOR HEAT AND RESET UP IF ANY AIR SYSTEM IS NOT SATISFIED BY THE GLYCOL SUPPLY TEMPERATURE.

ALL SETPOINTS ARE OPERATOR ADJUSTABLE.

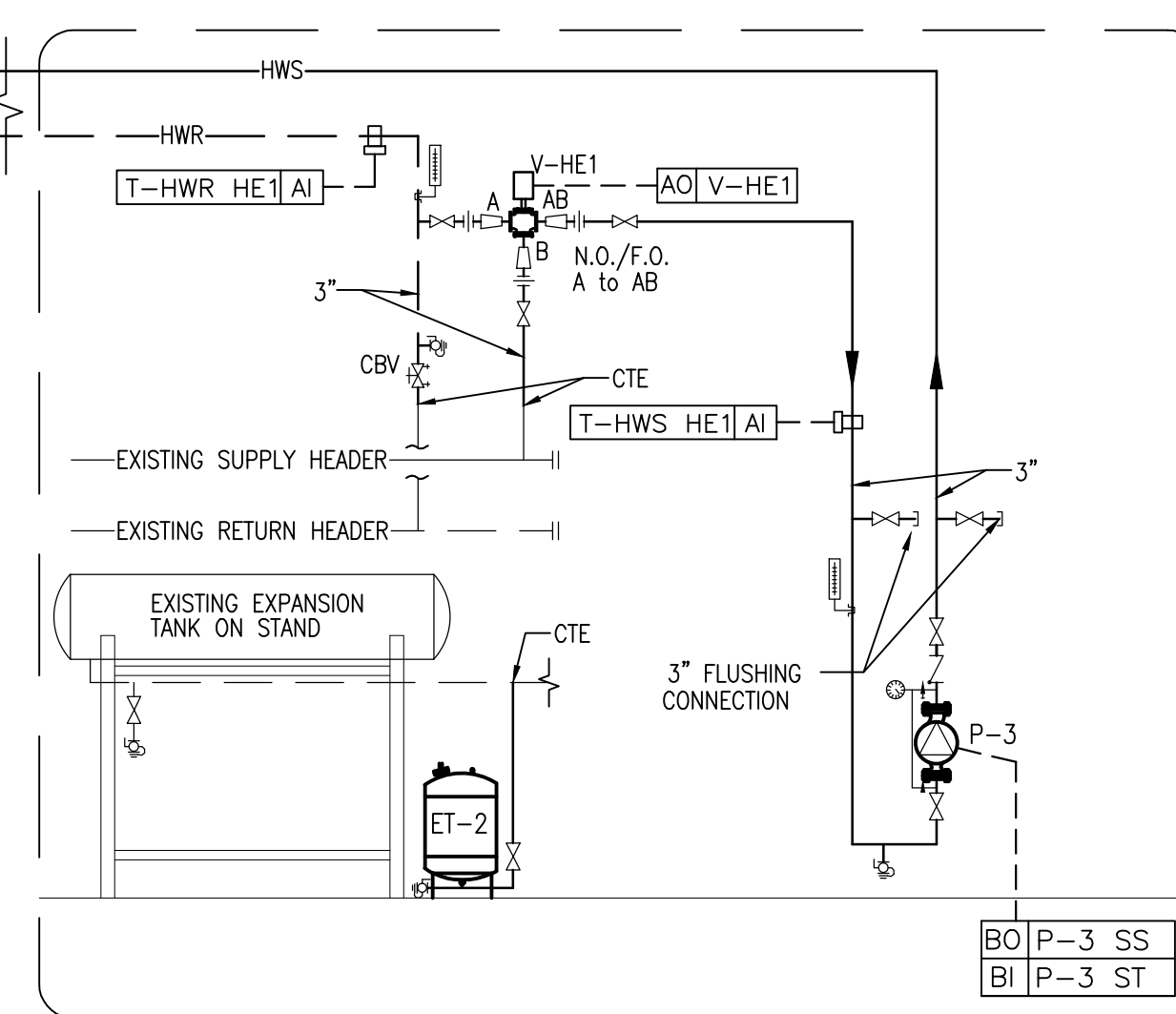

BOILER ROOM 117

1 HYDRONIC SCHEMATIC - CONTROLS  
MC602

**SEQUENCE OF OPERATION**

THE CONSTANT VOLUME AIR HANDLING UNIT CONSISTS OF AN OUTDOOR AIR DAMPER, FILTER, HEAT WHEEL WITH BYPASS, GLYCOL HEATING COIL, SUPPLY FAN EXHAUST FAN AND EXHAUST DAMPER.

ALL SUGGESTED SET POINTS AND SETTINGS ARE ADJUSTABLE.

THE AIR HANDLING UNIT IS SCHEDULED FOR AUTOMATIC OPERATION ON A TIME OF DAY BASIS FOR OCCUPIED AND UNOCCUPIED MODES.

IF A FAN IS MANUALLY TURNED OFF FOR MAINTENANCE, THE ENTIRE AIR HANDLING UNIT IS TO SHUT DOWN WHEN THE FAN STATUS CHANGES. WHEN THE MAINTENANCE RESET BUTTON IS PRESSED THE ENTIRE AIR HANDLING UNIT TO START IN AN ORDERLY MANNER.

**OCCUPIED**

WHEN THE AIR HANDLING UNIT IS SCHEDULED IS ON, THE BAS WILL ENABLE THE UNIT CONTROLS, THE OUTDOOR AIR DAMPER, AND THE HEAT WHEEL WITH BYPASS IN TO RECOVERY MODE. AFTER THE DAMPER IS FULLY OPEN, DAMPER ACTUATOR AUXILIARY SWITCHES CLOSES AND STARTS THE SUPPLY FAN AND EXHAUST FAN. THE HEATING COIL VALVE MODULATES TO MAINTAIN THE SUPPLY AIR TEMPERATURE SET POINT WITH A LOW LIMIT OF 12° C AT THE HEATING COIL DISCHARGE.

HEAT WHEEL BY PASS DAMPER SHALL MODULATE TO MAINTAIN THE EXHAUST AIR TEMPERATURE ABOVE FROST PROTECTION SETPOINT. THE FROST PROTECTION EXHAUST AIR TEMPERATURE SETPOINT SHALL BE INITIALLY SET AT 2° C AND SHALL BE OPERATOR ADJUSTABLE.

SUPPLY AIR TEMPERATURE TO BE CONTROLLED TO 18° C AND RESET FROM RETURN AIR. FOR RETURN AIR TEMPERATURE DEVIATION FROM 22° C, RESET SUPPLY AIR UP +1° C IF RETURN AIR IS -2° C BELOW SETPOINT AND RESET SUPPLY AIR DOWN -4° C IF RETURN AIR IS +4° C ABOVE.

IF OAT IS ABOVE 14° C, COIL PUMP IS DE-ENERGIZED.

IF OAT IS BELOW 12° C, COIL PUMP OPERATES WHEN UNIT IS ON.

IF THE OAT IS 6° C OR ABOVE, COIL PUMP IS OFF WHEN UNIT IS OFF.

IF OAT IS BELOW 5° C, COIL PUMP OPERATES CONTINUOUSLY.

WHEN TEMPERATURES BELOW 3° C ARE SENSED AT THE LOW TEMPERATURE DETECTOR IN THE DISCHARGE OF THE HEATING COIL, DE-ENERGIZE THE FANS, CLOSE THE DAMPERS AND GENERATE A BAS ALARM.

**UNOCCUPIED**

THE SUPPLY FAN IS OFF, RETURN FAN IS OFF, THE OUTDOOR AIR DAMPER IS CLOSED.

IF THE OAT IS LESS THAN 5° C, THE BAS CYCLES THE HEAT PUMP TO MAINTAIN THE UNOCCUPIED PLENUM TEMPERATURE OF 18° C.

IF THE OAT IS 6° C OR ABOVE, THE HEATING COIL PUMP DOES NOT OPERATE.

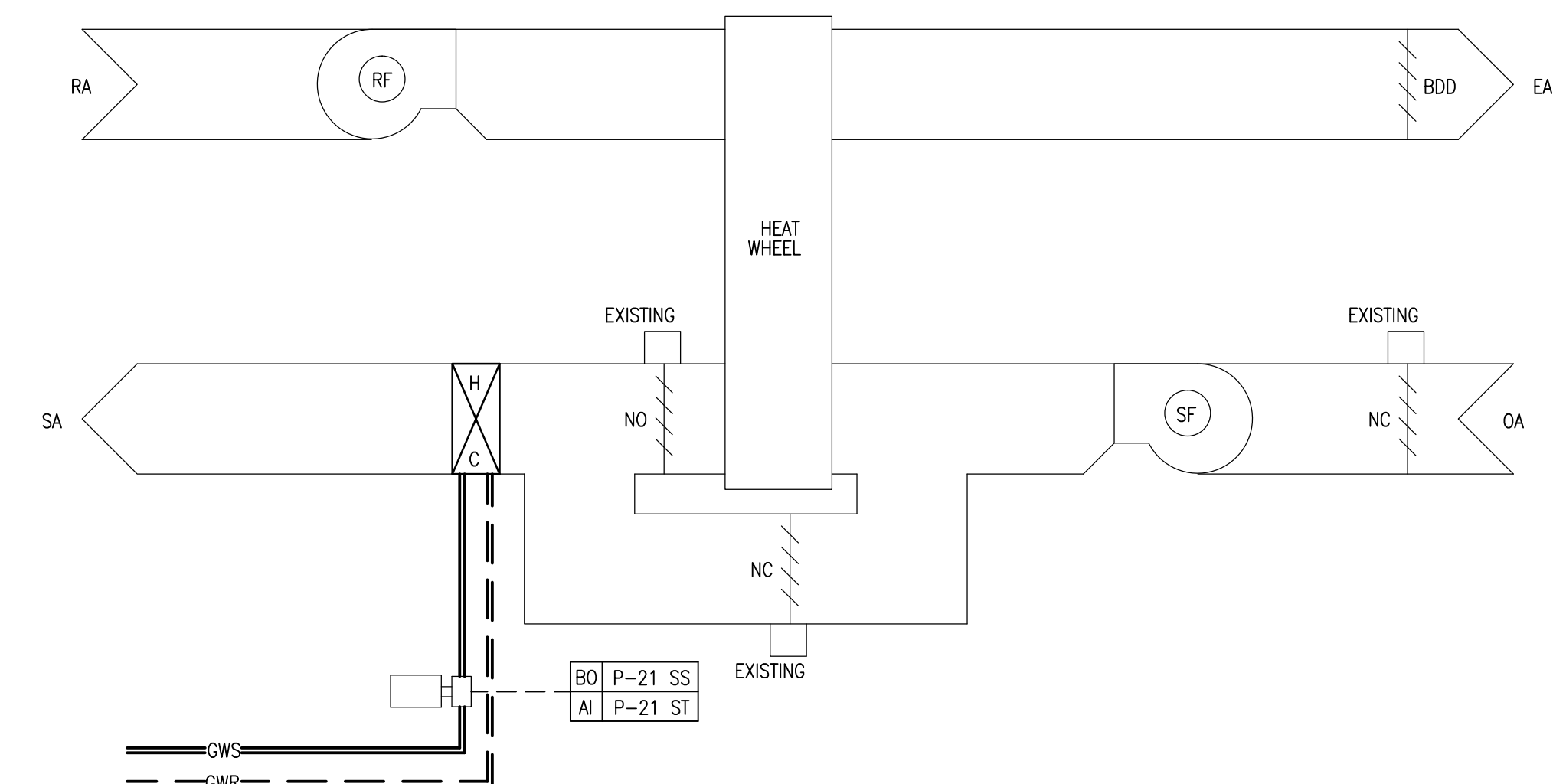

3 HEATING COIL CONTROL SCHEMATIC  
MC602

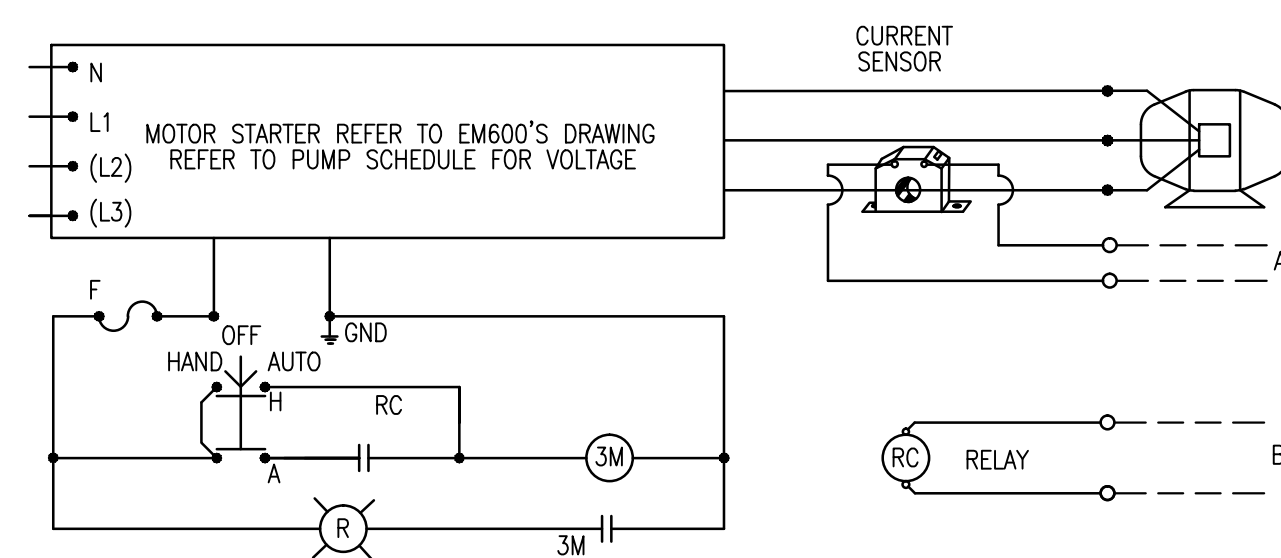

2 PUMP WIRING SCHEMATIC  
MC602

**NOTES**

1. REFER TO DRAWING E9101 FOR MOTOR STARTER AND CONTROL LIST.
2. WHERE NOTED, CURRENT SENSOR AND RELAY 'RC' PROVIDED BY ELECTRICAL CONTRACTOR, REFER TO ELECTRICAL SPECIFICATION.
3. CONTROLS CONTRACTOR TO CONTROL RELAY 'RC'. PROVIDE ADAPTORS AS REQUIRED.
4. CONTROLS CONTRACTOR TO READ CURRENT SENSOR. PROVIDE ADAPTORS AS REQUIRED.

GRAPHIC SCALE

04 JUN 15 1 ISSUED FOR TENDER  
DATE MARK ISSUE

STAMP

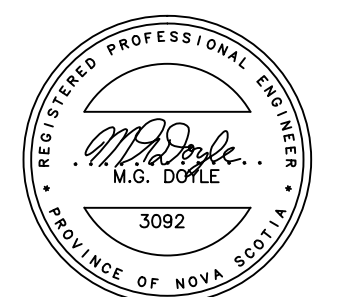

SCALE AS NOTED

DRAWN BY: STAFF

CHECKED BY: MGD

REVIEWED BY: MGD

APPROVED BY: MGD

AS-BUILT CHECK

DATE: MAY 2015

PROJECT  
BEECHVILLE LAKESIDE  
TIMBERLEA SCHOOL  
HEATING COIL

JAMES STREET, TIMBERLEA, NS

PROJECT NO.:

SHEET TITLE

CONTROLS

INTERNAL NO.: HRSB #3753

MC602



